

H. W. SPANG.

FIRE-ALARM TELEGRAPH.

No. 180,282.

Patented July 25, 1876.

Fig. 1.

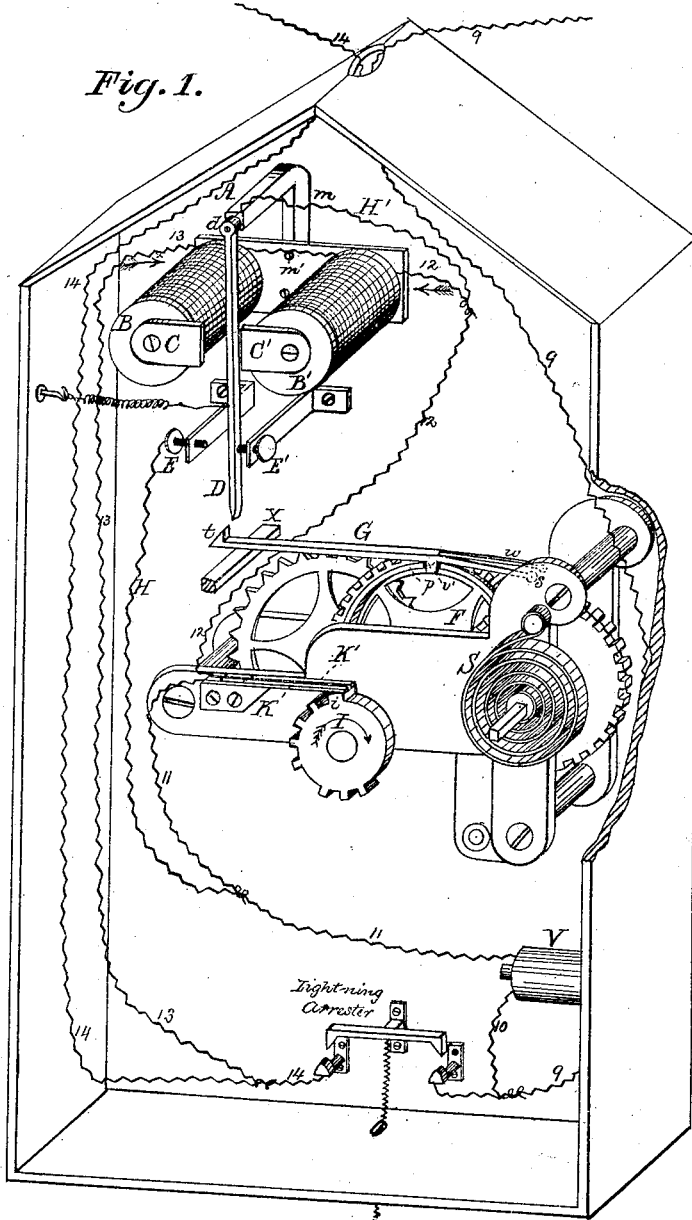

Fig. 3.

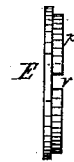

Fig. 4.



WITNESSES—

Phil W. Hale,
 Parker H. Sweet, Jr.

Ground Plate.

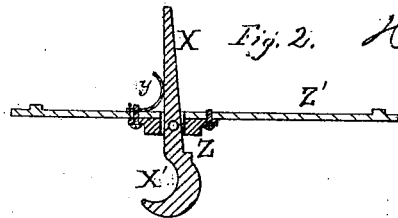

Fig. 2.

INVENTOR

Henry W. Spang
 Per W. Beale Hale,
 Attorney

H. W. SPANG.
FIRE-ALARM TELEGRAPH.

No 180,282.

Patented July 25, 1876.

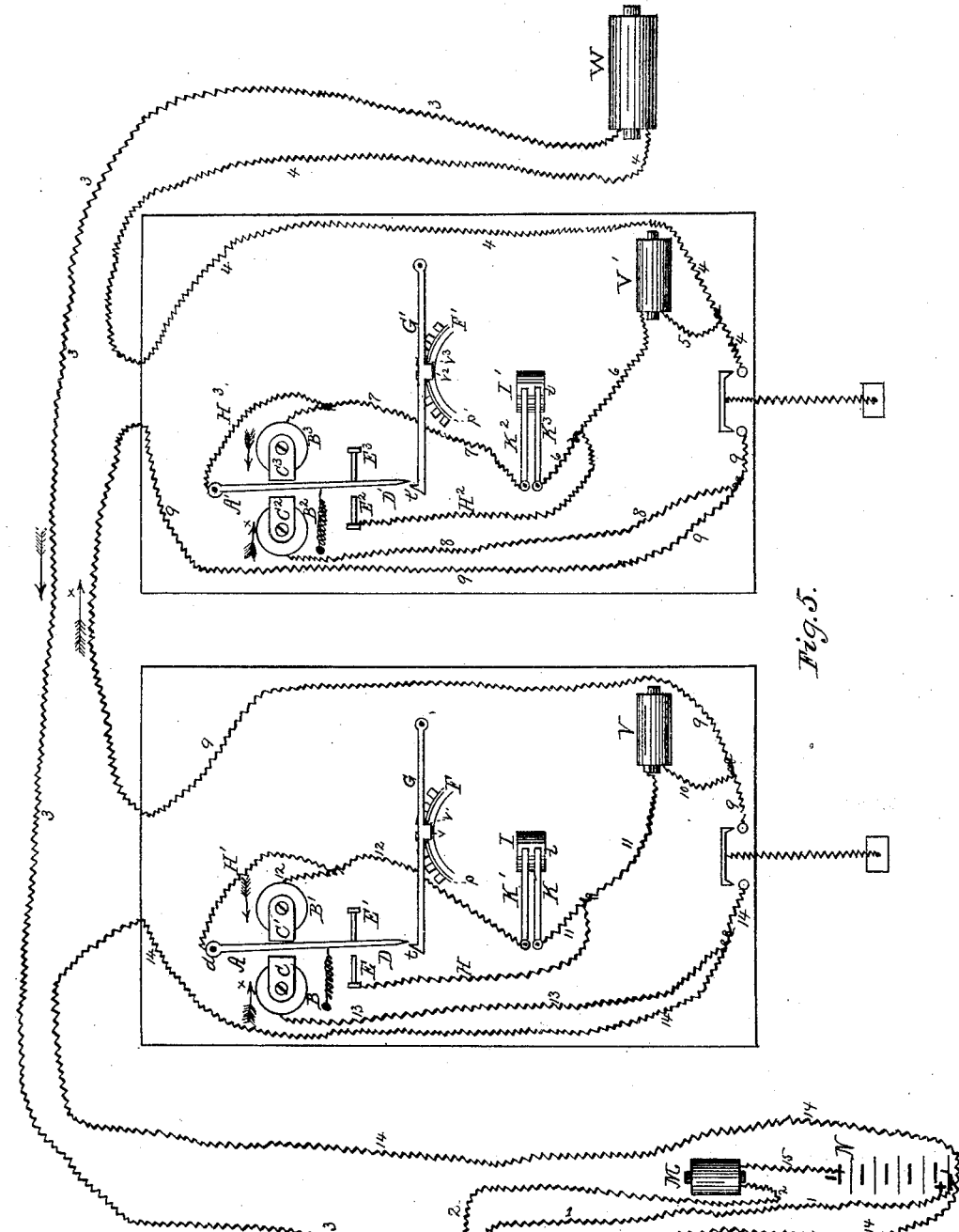

Fig. 5.

WITNESSES—

Parker H. Sweet Jr.
S. P. Hollingsworth.

INVENTOR—
Henry W. Spang,
per
W. Beale Hale,
Attorney.

UNITED STATES PATENT OFFICE.

HENRY W. SPANG, OF READING, PENNSYLVANIA.

IMPROVEMENT IN FIRE-ALARM TELEGRAPHS.

Specification forming part of Letters Patent No. **180,282**, dated July 25, 1876; application filed April 11, 1876.

To all whom it may concern:

Be it known that I, HENRY W. SPANG, of Reading, in the county of Berks and State of Pennsylvania, have invented certain new and useful Improvements in Fire-Alarm Telegraph System and Apparatus; and I do hereby declare that the following is a full, clear, and exact description thereof, which will enable others skilled in the art to which it appertains to make and use the same, reference being had to the accompanying drawings, and to the letters of reference marked thereon, which form a part of this specification.

Figure 1, Sheet 1, is a perspective view of the interior arrangement of a fire-alarm signal-box constructed according to my invention. Fig. 2 is a central sectional diminished view of the cover of a signal-box, showing the lever employed to set the motive-train in operation. Figs. 3 and 4 show details of the locking and running mechanism of a signal-box. Fig. 5, Sheet 2, is a diagram, representing two signal-boxes, a circuit-reverser, and battery, and showing the application of my invention to a single fire-alarm-telegraph circuit.

My invention relates to that class of fire-alarm telegraphs in which a series of signal-boxes or intermittent circuit-breaking apparatuses are included in the same electric circuit, said boxes being usually located at some distance apart, and the circuit being connected with a main battery at a central station; also, with suitable apparatus for automatically causing an alarm to be given upon all or as many of the alarm-circuits in a city or town as may be desired, when one of the signal-boxes is operated. The signal boxes or stations are located at suitable points or places in a city or town, and the signal communicated through the circuit, by each box, to the fire-engine, hose, and truck companies, each of which has an electro-magnetic or electro-mechanical sounding apparatus connected upon the same or different circuits, indicates the station from which it emanates, and thus informs the firemen to what point they shall proceed.

In order that a signal-box may communicate its information correctly, it is necessary that it shall not be interfered with while in the act of signaling its number. The chief danger of interference with a signal-box while

it is in operation comes from the attempt to send in an alarm from another box in the same circuit, or in a different circuit connected with the same apparatus at a central station; and it is perfectly obvious to any one acquainted with electrical apparatus that, unless proper provision is made against it, confusion of signals will inevitably result from the attempt to send alarms at the same time from two signal-boxes in the same circuit, or in separate circuits connected as above mentioned.

In the fire-alarm-telegraph systems of Messrs. Channing and Farmer (originally introduced in this country and patented in the United States in 1857 and 1859) no provision was made against the interference of signal boxes or circuits one with the other. The great loss of property resulting at various times and places from the failure of firemen, fire-engines, hose and ladder companies, to promptly reach the sites of fires, owing to the confusion of signals from two or more boxes, as set forth, has caused different persons to endeavor to remedy this defect in the systems of fire-alarm telegraphs heretofore employed. Several systems or methods of non-interference have been devised, among which I will name those of John N. Gamewell, patented April 11, 1871, No. 113,649; J. W. Kates, July 13, 1875, No. 165,591; Moses G. Crane, July 27, 1875, No. 165,918; and that alluded to by S. Chester in patent No. 164,425, June 15, 1875, and No. 169,087, October 26, 1875, in all of which an ordinary electro-magnet, the armature-lever of which controls or actuates the devices for preventing interference during an alarm, is employed, which is operated by a single current, or, rather, a current always flowing, when the circuit is closed, in one direction.

The system of non-interference heretofore generally employed in this country is that of John N. Gamewell, and the improvements thereon made by Moses G. Crane, for a full description of which I refer to the Letters Patent above named, merely here stating that in said systems the inventors attempt to prevent interference by causing an automatic intermittent shunting of the circuit from the break-circuit wheels or signaling-wheels of all the signal-boxes in a given circuit, except the box which is first pulled and is in opera-

tion. This intermittent shunting is effected by the armature of an electro-magnet in each box which is included in the main circuit, which is always closed when no box in said circuit is in operation, and therefore the armature is attracted by the iron cores of said magnet. In this position the break-circuit wheels of all the boxes are in the normal condition of the circuit, and any box may be started to operate, and the first movement of the break-circuit wheel breaks the main circuit. Then all the armatures in all the boxes, except the one pulled, are drawn by springs away from the cores of the magnets, and as long as they remain so the circuits of the signaling-wheels of said boxes are shunted out of the main circuit, and if any box were then attempted to be operated its signaling-wheel would be locked out of said circuit, and the box could not interfere with the one signaling. But the armature-levers do not long remain in this position, for in order to send in its signal the wheel of the operating-box must close the circuit a given number of times, and every time the circuit is so closed the armatures in all the other boxes are attracted by the cores of their magnets, and the signaling-wheels of all said boxes are brought into the circuit. If any box were then, while the circuit was so closed, operated, it would interfere with the box at the time of signaling, and cause a confusion of signals, so that the firemen would not know to what point to go with their apparatus. For instance, if the box operated were numbered 53, it would cause, first, five bell-taps, and after a short pause three more. Its first bell-tap would be caused by its first breaking-circuit, and it would then have to close and break circuit four, and then three, times, making seven times that it would give any other box electrically connected therewith an opportunity to interrupt it and confuse its signals.

The defect which I have just explained is one, but not the only one, for which my invention provides an effectual remedy. A defect exists in all the so-called non-interference systems heretofore devised, arising from the unreliability of operation of the armature-levers of the ordinary electro-magnets employed in fire-alarm signal-boxes, and particularly when the resistance of the non-interference magnets is less than the resistance of the gong and other magnets employed in the circuit; also, when the iron signal-boxes are exposed to excessive heat during the summer, and excessive cold during the winter. Experience has fully demonstrated that, owing to the expansion and contraction of the metal of which the cores and armatures of these magnets are composed, and the varying strength of the battery-current, resulting from leakage and other causes, the armature-levers of these magnets are frequently thrown out of proper adjustment in fire-alarm signal-boxes, and, in consequence, the proper action of the electrical apparatus

which is dependent upon such a magnet in a fire-alarm-telegraph signal-box, operated by a single current, can only be secured by constant personal attention.

It is a well-known fact with the telegraphic fraternity that, in an office of a regular telegraph-line, where there is generally a moderate and not an excessive temperature of weather, when there is a heavy or long-continued rain, or excessive moisture in the atmosphere, the adjustment of the armatures of the relays must be changed in consequence of the leakage of the battery-current; also partly owing to the effect produced by moisture upon the cotton or silk thread or cord attached to the adjusting-spring. The same causes which render the armature-levers of the relay-magnets of an ordinary telegraph-line inoperative, unless readjusted, produce, to some extent, a similar effect upon the armatures of the electro-magnets in fire-alarm-telegraph signal-boxes, where, from the nature of the case, a constant personal supervision is impossible.

The difficulties in fire-alarm telegraphy, hereinbefore explained, can be effectually obviated by employing in signal-boxes polarized electro-magnets, arranged to be operated by reversed or opposite currents, as, for such magnets, operated by reversed currents, no regulating or adjustment of the armature-lever is required to meet the varying expansion and contraction of metals, and no matter what ordinary strength of battery-current may be applied to the circuit, or what escape or amount of moisture there may be, the armature-levers of the polarized magnets always respond to the reversed or opposite currents.

My invention, which insures the regular and orderly giving of signals, consists, broadly, in the combination of a polarized electro-magnet, the armature-lever of which controls or actuates the device or devices employed to prevent interference during the giving of an alarm-signal within each fire-alarm signal-box upon each circuit, with a circuit-reverser at the central station, the whole being arranged so that when a box is "pulled" it will control the circuit, and an alarm or interference is prevented from being made at any other box upon the same circuit, or upon any circuit connected with the same apparatus at the central station, through the medium of the current, which is automatically reversed at the central station upon each circuit immediately after a box is pulled, and continues reversed until the alarm of the box pulled is given, and thereby properly actuates the armature-levers of the polarized magnets, and prevents interference.

I do not propose here to confine my claims to any specific methods or devices for embodying the principle of my invention, but will now, with reference to the accompanying drawings, proceed to describe an apparatus which I have employed involving said principle, and illustrating one of the methods in which I have contemplated applying the same.

In Fig. 1, Sheet 1, I is a break-circuit or signaling wheel, rotated by the stress of spring S through the train of wheels shown in the figure. A is a polarized electro-magnet, the armature-lever D of which is pivoted at *d* upon one end or pole of a bent permanent magnet, *m*. B B¹ are the helices, which are attached to an iron cross-bar, *m'*, which is attached to the other end of the bent permanent magnet. These helices are so wound and connected together (as will be readily understood by those familiar with polarized electro-magnets,) that when the electric current flows in the direction of the arrow from wire 12 to 13, the magnetized pole C of the polarized electro-magnet will attract lever D, and when the current flows in the direction of the arrow from 13 to 12, the said lever D will be attracted by pole C'. E is a metallic adjustable screw, connected by wire H with wire 11, which is connected with metallic spring-finger K. E' is an insulated adjustable screw. H' is a wire, forming connection between lever D and metallic spring-finger K'. V is an ordinary electro-magnet for operating a small bell inside the box, and its armature-lever requires occasional readjustment. The various numerals in this and other figures indicate connecting-wires, which will be hereafter referred to.

The locking mechanism, which I will now describe, is similar to that shown in the patent of Moses G. Crane, dated July 21, 1875, and numbered 165,918. I disclaim the invention of this mechanism in itself. F, one of the gear-wheels of the train, has on its side face, at its periphery, a flange, *p*. (Seen plainly in Figs. 2 and 3.) G is a lever, pivoted at one end at *s*. Upon the opposite end is a hook or upward wedge-like projection, *t*. This lever rests upon the flange *p*, toward which it is pressed by a spring, *w*. Upon its under side is a lug, *v*, and in the flange *p* is a notch, *v'*, into which the lug falls when the wheel F is in position where the lug and notch coincide. While the lug is in the said notch the wheel F is locked and cannot move; but by lifting the lever G, the lug being thereby disengaged from the notch, the wheel F will make, under the stress of the main spring, a complete revolution, the lug resting in the meantime on the flange, and thereby maintaining the lever G in its raised position.

The wheels of the train may be so proportioned that the break-circuit wheel will make any number of revolutions while wheel F is making one. If, at the time lever G is raised in any box, the circuit is closed, and the current is flowing in its normal direction, the lever D of the polarized electro-magnet A is then attracted by pole C¹ of said magnet, and makes contact with insulated screw E¹, and the hook *t*, being thrown up on the left side of the beveled end of lever D, locks said lever in that position, with the break-circuit wheel of the box locked in the circuit. But if at the time the lever G is raised an alarm

is being given at another box, the circuit is then either open or reversed, and the armature-lever D will then be drawn away from pole C¹ of the magnet by the action of a spring, if the circuit is open, or be attracted by the opposite pole C, if the circuit is reversed; and the hook *t* will be thrown up on the right-hand side of the beveled end of the armature-lever, and lock it in that position, with the break-circuit wheel of the box locked out of the circuit, as will be hereinafter more fully explained. Z is a lever, pivoted in the cover Z' of the box, one arm, X, of which extends into the box, immediately under the hooked end of lever G. The opposite end X' of lever Z extends outward from the box-cover. The person giving an alarm depresses this end X' of the said lever, and thereby throws up the lever G. As soon as the pressure is removed from X' the spring *y* throws down the end X, and leaves lever G free to fall back to its normal position.

For winding the mainspring of the train a lever may be connected to its shaft, and with a suitable finger-lever or hook in any convenient manner; or said spring may be wound up by a separate crank, the shaft of said spring projecting through the inner box-cover, so that the crank may be fitted to it. This box is intended, as I have before stated, to be used with a closed circuit, and the alarm to be given by breaking the circuit by the revolution of the break-circuit wheel, upon the broad-faced tooth *i* of which the metallic spring-fingers K¹ K rest normally, and said wheel is then included in the circuit which is closed through said tooth, and flows through the metallic spring-fingers.

I will now describe the circuit-reverser O, Fig. 5, Sheet 2, which is supposed to be at a central station, after which I will explain the operation of one method of applying my system of non-interference, and in so doing I will refer to the same figure, viz., 5, which is a conventional diagram, showing two signal-boxes, a circuit-reverser, and a gong-sounding magnet. The said circuit-reverser is similar to one shown and described in my Patent No. 168,058, for electric railroad-signals, dated September 21, 1875. It consists of four metallic spring-fingers, *f f¹ f² f³*, insulated or separated from each other, which firmly press upon, and alternately make contact with, the metallic plates *q q¹ q² q³ q⁴ q⁵*, which are separated from each other, and are fastened upon the periphery of a solid hard-rubber cylinder, R, which is mounted upon, and makes a partial revolution with, the metallic shaft R', immediately after the first breaking of circuit during an alarm. Plates *q²* and *q³* are electrically connected together by a wire or other suitable conductor, *y*, and plates *q⁴ q⁵* by wire or conductor *y'*.

The shaft R' of the circuit-reverser R is moved by means of suitable mechanism, which is controlled by the armature-lever of ordinary electro-magnet M, the whole being so arranged

that when no alarm is given, and the magnet M is charged by the normal closed circuit, the armature-lever thereof will hold the mechanism and shaft R' in check, and the springs f f^1 will make contact with plate q , and springs f^2 f^3 with plate q^1 ; but immediately after the lever of a signal-box is pulled, and the circuit is broken by the break-circuit or signaling wheel thereof, and while the first tap of the alarm is being given, the magnet M will be demagnetized, and its armature-lever, by means of an adjustable spring, will release and cause the mechanism which holds shaft R' in check to operate, and shaft R' and cylinder R of the reverser to make a partial revolution, and springs f f^1 f^2 f^3 to make contact, respectively, with plates q^2 q^4 q^3 q^5 , and thereby reverse the current of battery N, and shaft R will continue to remain in the latter position during the whole alarm, or for a specified length of time, when the operating mechanism will restore it to its normal position, and thereby also cause the current to resume its normal direction.

I have not deemed it necessary to lengthen these specifications by showing or fully describing the various devices or mechanism by which the shaft R' may be caused to make a partial revolution, and thereby cause the current to be reversed immediately after the first breaking of circuit during an alarm, and to continue in the latter position and the current to be reversed during the whole or part of an alarm, as there are a number of devices and methods that can be employed for that purpose, among which I will mention the method shown in Patent No. 165,923, granted July 27, 1875, to Gamewell, Crane, and Rogers, for improvement in fire-alarm repeaters, in which a vertical shaft numbered 13, which actuates a governor marked J, is caused to make a partial revolution after the first breaking of circuit during an alarm, and continues in the changed position during an alarm, and is restored to its normal position after the alarm is given, which could be applied to shaft R' in a similar manner.

The springs and plates of reverser O can be so arranged that when the shaft R' and cylinder R return to their normal position, after an alarm is given, the current of battery N will be momentarily short-circuited by the reverser, and cause a single tap to be given upon all the gongs and bells in the circuit beyond the reverser, thereby indicating that the shaft R' and the reverser have resumed their normal positions, and everything is working properly at the central station. The said springs and plates, or the magnets of the alarm gongs and bells, can also be so arranged that the momentary short-circuiting after an alarm will be so very brief that it will be impossible to demagnetize the magnets of the gongs and bell-strikers quick enough to give the single tap after an alarm, as above referred to. Upon shaft R' a circuit-reverser for each circuit can be placed, so that when an alarm

is being given at a box upon one circuit the currents will also be simultaneously reversed upon all the other or several circuits, and non-interference secured upon and between all the circuits, or several of them, if desired. In such case it is necessary that shaft R' shall be actuated by mechanism which is controlled by each circuit.

I will now describe the operation of my invention, referring to Fig. 5, Sheet 2.

Let us suppose that no alarm is being given, and the fire-alarm circuit to be closed, (though I do not confine myself to a closed circuit,) and the current flowing in its normal direction, and then the armature-levers D D' of the polarized magnets A A' in the signal-boxes are attracted by the right-hand poles C¹ C³ of the said magnets, and make contact with insulated screws E¹ E³, and the levers G G' are in their normal position. The electric current of the battery N is now flowing in direction of the arrows from the positive pole thereof, over wire 1, spring-finger f^2 , plate q^1 , spring-finger f^3 , wires 14 13, helices B B¹ of magnet A, wire 12, finger K¹, break-circuit wheel I, finger K, wire 11, small bell-magnet V, wires 10 9 8, helices B² B³ of magnet A', wire 7, finger K³, break-circuit wheel I', finger K², wire 6, small bell-magnet V', wires 5 4, bell-striker or gong-magnet W, wire 3, spring-finger f , plate q , spring-finger f^1 , wire 2, circuit-reverser magnet M, and wire 15, to the negative (—) pole of the battery.

Let us, now, further suppose that the lever Z of one of the boxes—say, the right-hand one—has just been pulled, or the mechanism started to operate for the purpose of giving an alarm. By the pulling down of lever Z, lever G' has been raised so that lug v'' has been withdrawn from the notch v''' , and wheel I' has begun to revolve. Hook or projection t' has caught upon the left-hand side of lever D', and holds or locks it against insulated screw E³, where it will be held until wheel I' makes a complete revolution, and lever G' falls to its normal position. When the break-circuit wheel I' has revolved in the direction of the curved arrow far enough to move the first tooth of said wheel away from under the metallic spring-fingers K² K³, and said fingers do not rest upon any tooth, and being separated or insulated from each other, the circuit is, of course, broken. The circuit now being broken, the right-hand poles of the polarized electro-magnets in the signal-boxes have ceased to strongly attract the armature-levers, and in all the boxes, except the one pulled, (the armature-lever of which is locked by hook t' .) the armature-levers have been pulled away by their springs from the said poles, and are now held against the opposite screw, E, as shown in the left-hand box, and shunt the circuit to the break-circuit or signaling wheel I out of the main circuit, and cause the current to flow over wire H, metallic screw E, lever D, and wire H'. The circuit-reverser magnet M, at the central station, at

the same time, while the circuit is thus broken, becomes demagnetized, and its armature-lever, being retracted by a spring, releases the mechanism which actuates the shaft R' and cylinder R, and allows the said shaft and cylinder to make a partial revolution, and cause the spring-fingers $f f^1 f^2 f^3$, which nominally make contact with plates $q q^1$, then to make contact respectively with plates $q^2 q^4 q^3 q^5$, and thereby reverse the current when the next tooth of the signaling-wheel I' closes the circuit, and the said mechanism will continue to keep it reversed until the alarm is completed, as heretofore explained.

When the current of battery N is reversed it flows in direction of arrows from the positive (+) pole thereof, over wire 1, spring f^2 , plate q^3 , wire y , plate g^2 , spring f , wire 3, bell-striker or gong-magnet W, wires 4 5, small bell-magnet V¹, wire 6, spring-finger K², break-circuit wheel I', spring-finger K³, wire 7, helices B³ B² of magnet A', wires 8 9 10; small bell-magnet V, wire 11, wire H, metallic screw E, lever D, wire H¹, wire 12, helices B¹ B of magnet A, wires 13 14, spring f^3 , plate q^5 , wire y' , plate q^4 , spring f^1 , wire 2, circuit-reverser magnet M, and wire 15, to negative (-) pole of the battery N; and the left-hand poles of the polarized electro-magnets, owing to the reversal of the current, now attract the armature-levers, and all of the said levers except the one in the box pulled, which is locked by hook t , are retained in contact with the left-hand metallic screws, in which position they shunt the circuit away from the break-circuit or signaling wheels, as hereinbefore explained, and they will continue in said position during an alarm and until the current is, by the reverser, again restored to its normal direction; and if another box—say, the left-hand one in the diagram—should be pulled while the alarm is being given by the first box pulled, no interference or confusion would be caused, as the circuit of the break-circuit wheel of the last box pulled is shunted, principally through the influence of the reversed current passing over the helices B¹ B of magnet A, in the direction indicated by arrow and pole C, thereby attracting lever D and keeping it in contact with metallic screw E. The hook t in the last box pulled would be thrown up on the right-hand side of lever D, and there remain until wheel F had made a complete revolution.

The main object of the hook t or t' in this system of non-interference is to lock the armature-lever of the first box pulled in the position it occupies before the circuit is reversed, and prevent it from being moved by the reversed current during an alarm and placed in a position to shunt its break-circuit wheel while giving its alarm-signal.

The armature-levers of the non-operating boxes, it will be plainly seen, never do nor can return toward the right-hand poles of the polarized magnets until the first-pulled or op-

erating box has completed its signal and the current again flows in its normal direction.

The retracting-springs of the armature-levers of the polarized electro-magnets can be dispensed with, and the reversed current will cause said levers in the non-operating boxes to be attracted by the left-hand poles of the magnets, and to make contact with the left-hand screws, when the circuit is again closed, after the first breaking of the circuit, by the break-circuit wheel during an alarm, and they will continue in contact with said left-hand screws or points during the time the current is reversed, and until the whole alarm is given, without the aid of said springs.

It is obvious, from the foregoing explanation, that in my herein-described improved system of fire-alarm telegraph it is utterly impossible for one signal-box to interfere with another in the same circuit, or in a different circuit connected with the same central station, and that the regular and orderly giving of signals is positively insured.

The principle of my invention is susceptible of application in various modes. Instead of using the polarized electro-magnets and reversed current in the manner I have described, the armature-lever of a polarized electro-magnet operated by a reversed current may be employed to lock the running mechanism which actuates the break-circuit wheel or other suitable part of all signal-boxes during an alarm, except the first one pulled, or to throw a guard over the key-holes or locks of said boxes, so that no other box than the first one pulled can be unlocked during an alarm.

As I have hereinbefore stated, it is necessary to prevent lever D, Fig. 1, of the first box pulled from being actuated by the reversed current and making contact with metallic screw or point E, and thus shunting its break-circuit wheel, while giving its alarm; and instead of locking the said lever by the devices, as shown and described, while giving an alarm, it can be locked by means of various other devices.

Any kind of polarized electro-magnet may be used; but of those with which I am acquainted I prefer the Siemens form, which is extensively used in England upon the regular telegraph-circuits, as I understand that in no instance have the Siemens magnets been demagnetized by lightning in that country; neither are the large permanent magnetic bars employed apt to lose their magnetism.

In order to lessen the liability of the permanently-magnetized parts of polarized magnets losing their magnetism, they can be magnetized occasionally by the induction of an electro-magnet, strongly charged, placed in contact with or near them.

There are also some combinations of ordinary electro-magnets, arranged to be operated by reversed currents and work similarly to polarized magnets, which could be substituted

for polarized magnets in applying my invention; but such combinations are the equivalents of polarized electro-magnets, and their use would not change the principle as hereinbefore set forth.

There are many methods and devices known to electricians for reversing an electric current, and I may use any of such methods and devices that I may find suitable; and I may also use any kind of break-circuit wheel known at the present time, or any kind of circuit, as all of the substitutions I have referred to would be matters requiring no invention.

The application of the lightning-arrester illustrated in the drawings explains itself.

Having now explained my invention, and described the modes in which I have contemplated applying the same, I claim—

1. In a fire-alarm-telegraph circuit, the combination of a polarized electro-magnet, or its equivalent, in each signal-box, with a circuit-reverser, arranged to reverse the direction of the electric current while an alarm is being given, substantially as and for the purpose set forth.

2. In a fire-alarm-telegraph circuit, the combination of a polarized electro-magnet, or its equivalent, in each signal-box, the armature-levers of which, except that of the box first

pulled or set in operation, are arranged to shunt all the break-circuit wheels out of the main circuit during an alarm, with a circuit-reverser, arranged to reverse the direction of the current while an alarm is being given, substantially as and for the purpose set forth.

3. In a fire-alarm signal-box, the combination of the armature-lever of a polarized electro-magnet, arranged to be operated by a reversed current of electricity, with a device or devices for locking said lever in the position it is in when a box is pulled, substantially as and for the purpose set forth.

4. The combination of lever D of polarized electro-magnet A with hooked locking-lever G, substantially as described.

5. The combination of lever D of polarized electro-magnet A, metallic screw or post E, wires H H', wires 11 12 of the break-wheel circuit, and locking-lever G, substantially as shown, and for the purpose set forth.

In testimony that I claim the foregoing as my own invention I affix my signature in presence of two witnesses.

HENRY W. SPANG.

Witnesses:

E. R. ADAMS,

C. T. SELLERS.