

S. O. HALL.
GATE-LATCH.

No. 180,338.

Patented July 25, 1876.

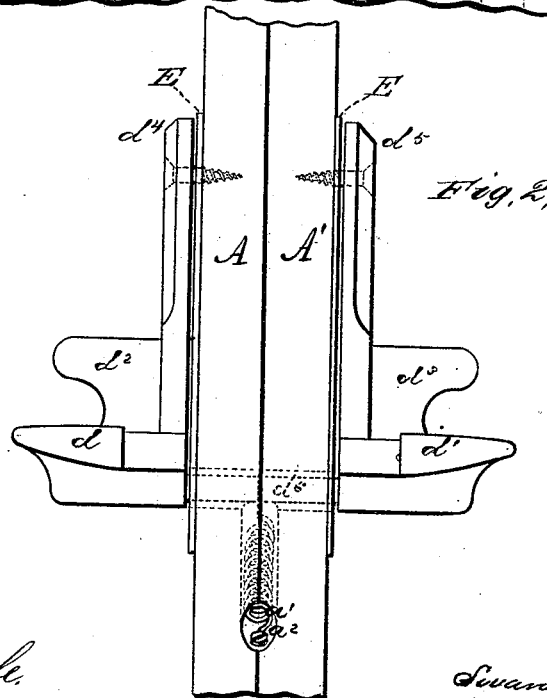
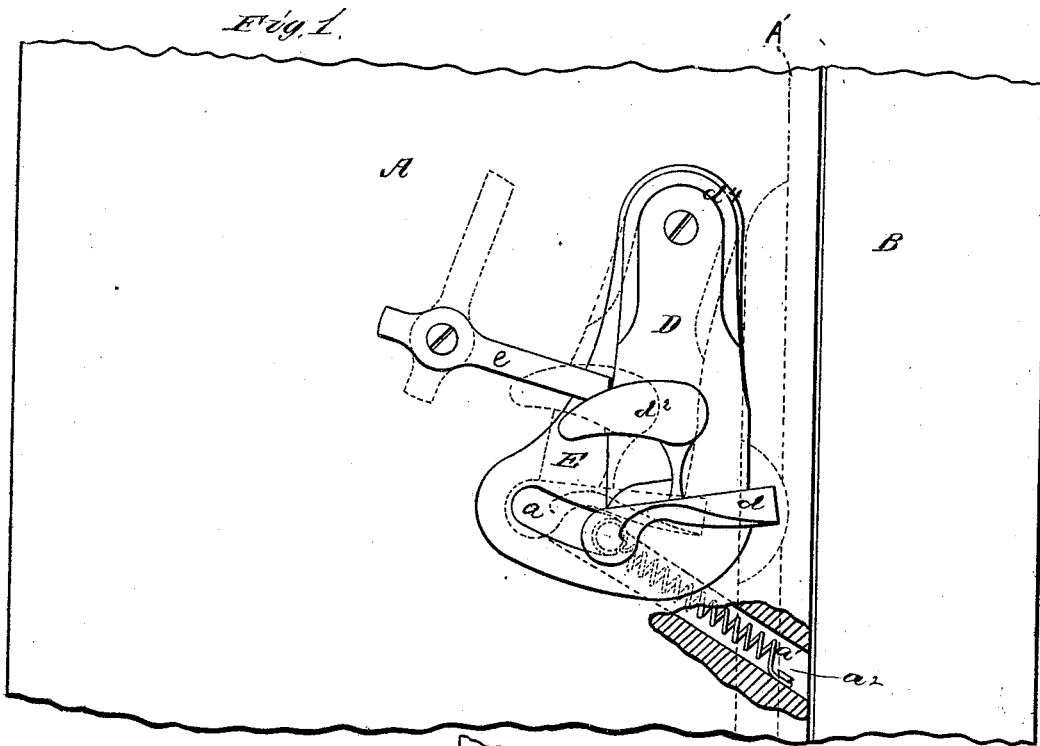

WITNESSES
C. R. Searle,
George E. Upham.

INVENTOR.
Swan O. Hall.
Gilmore, Smith & Co.
ATTORNEYS -

S. O. HALL.
GATE-LATCH.

No. 180,338.

Patented July 25, 1876.

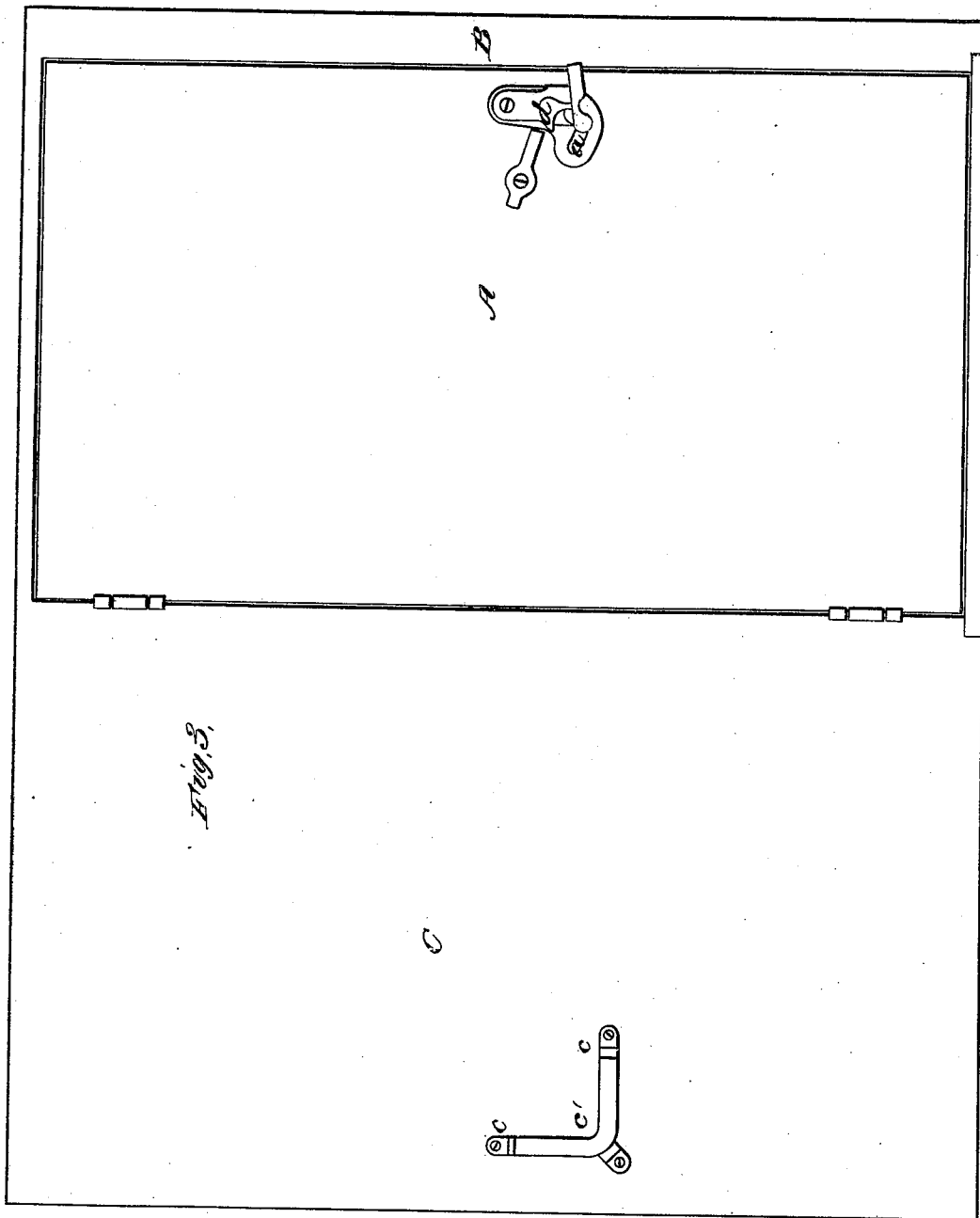

Fig. 3.

WITNESSES

C. W. Scarle
George E. Upham.

INVENTOR.

Swan O. Hall.
Gilmore Smith & Co.
ATTORNEYS.

S. O. HALL.
GATE-LATCH.

No. 180,338.

Patented July 25, 1876.

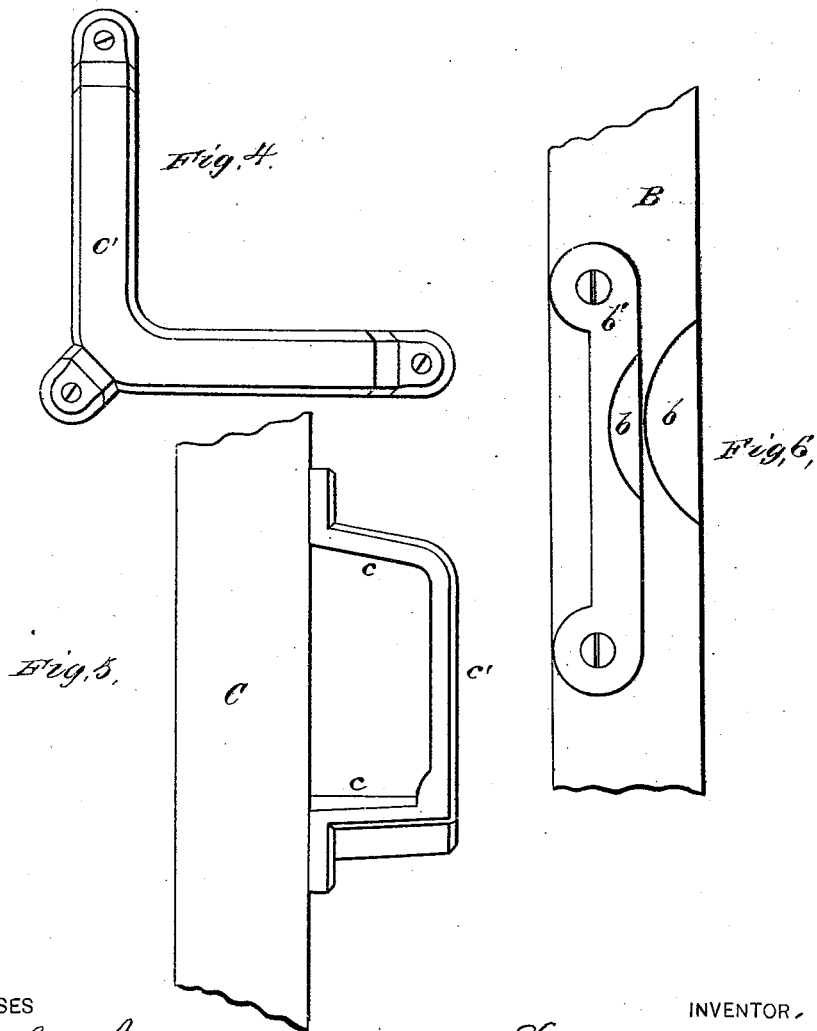

WITNESSES

C. H. Searle.
George E. Upham.

INVENTOR,

Swan O. Hall.
Gilman & Smith, Esq.
ATTORNEYS

UNITED STATES PATENT OFFICE.

SWAN O. HALL, OF OSCEOLA, IOWA.

IMPROVEMENT IN GATE-LATCHES.

Specification forming part of Letters Patent No. 180,338, dated July 25, 1876; application filed May 27, 1876.

To all whom it may concern:

Be it known that I, SWAN ORSON HALL, of Osceola, in the county of Clarke and State of Iowa, have invented a new and valuable Improvement in Gate-Fasteners; and I do hereby declare that the following is a full, clear, and exact description of the construction and operation of the same, reference being had to the annexed drawings, making a part of this specification, and to the letters and figures of reference marked thereon.

Figure 1 of the drawings is a representation of a front elevation of my gate-fastener, and Fig. 2 is an edge view of the same applied to a gate. Fig. 3 is a front view of the latch attached to a gate, and the catch-piece attached to the wall. Figs. 4, 5, and 6 are detail views thereof.

This invention relates to devices for holding a gate or door open or closed; and it consists in a peculiarly-constructed double latch and auxiliary devices, substantially as hereinafter set forth and claimed.

In the accompanying drawings, A designates a gate; B, a gate-post, against which the gate A shuts; and C, the wall or fence. D is a double latch, which consists of corresponding catch-pieces d d' , handles d^2 d^3 , arms d^4 d^5 at the top, and connecting-piece d^6 at the bottom. One of the corresponding halves of this double latch is arranged on each side of gate A, and pivoted thereto at the top through arms d^4 d^5 . Connecting-piece or guide-rod d^6 moves backward and forward in curved slot a , cut through door A. To this connecting-piece d^6 is attached one end of helical spring a^1 , the other end of which is made fast to door A. Spring a^1 operates in a recess, a^2 , cut in said door A. That side of the gate or door A which comes in contact with the gate-post B is provided with an offset, A' , (shown by dotted lines in Fig. 1,) and the curved slot a is extended through such offset, so that the catch-piece d' will be on the outside of said offset. Offset A' is not carried quite out to the edge of door A, so that a small part of said door A may be adapted to strike against the gate-post or door-jamb B, while the end of offset A' will just pass inside of said door-jamb or gate-post. Slotted face-plates E may be interposed between the sections of the double latch D and the adjacent faces of the door A or offset A' . Gate-post B is carved away, forming a bevel

at b , to allow the passage of the catch-piece d' when the door is being closed; and it is provided with a shoulder, b' , for locking said catch-piece. On wall C are rigidly fastened the projecting arms c c c , which bear the flat piece c' , adapted to engage with and hold the catch-piece d' when the gate is thrown back against it. The side of piece c' nearest to the door is beveled, and so is the outer end and side of each one of the catch-pieces d d' . On the outside of the door A is a pivoted button or lever, e , which is adapted to lock the double latch D firmly.

The operation is as follows: When the gate A is shut the latch D is made to swing inward by the beveled surface b of the gate-post B, which comes in contact with the beveled outer end of the catch-piece d' . As shoulder b' is also beveled at the point where it is first struck by catch-piece d' , said catch-piece will ride over said shoulder, and will catch behind the same when drawn forward by spring a^1 . The button or small lever e is then turned so as to lock the parts. In opening the door the button e is first turned out of the way, and then the latch D is drawn back by the aid of the handle d^2 or d^3 . When the gate A is thrown wide open the locking action is substantially the same as when closed, except that the projecting piece c' takes the place of shoulder b , and catch-piece d takes the place of catch-piece d' .

This device is applicable to doors as well as gates.

What I claim as new, and desire to secure by Letters Patent, is—

1. The gate A, provided with the curved guide-slot a , recess a^2 , and spring a^1 , in combination with double latch D, having catches d d' and handles d^2 d^3 , substantially as described, and for the purpose set forth.

2. The gate-post B, provided with shoulder b' , obliquely cut away at b , in combination with the gate A, having slot a , recess a^2 , spring a^1 , and a swinging latch, having a catch, d' , handle d^3 , and guide-rod d^6 , substantially as described, and for the purpose set forth.

In testimony that I claim the above I have hereunto subscribed my name in the presence of two witnesses.

SWAN ORSON HALL.

Witnesses:

GEO. W. WILSON,
J. GOLDSMITH.