

W. C. HUFFMAN.
STONE-SAWING MACHINE.

No. 180,344.

Patented July 25, 1876.

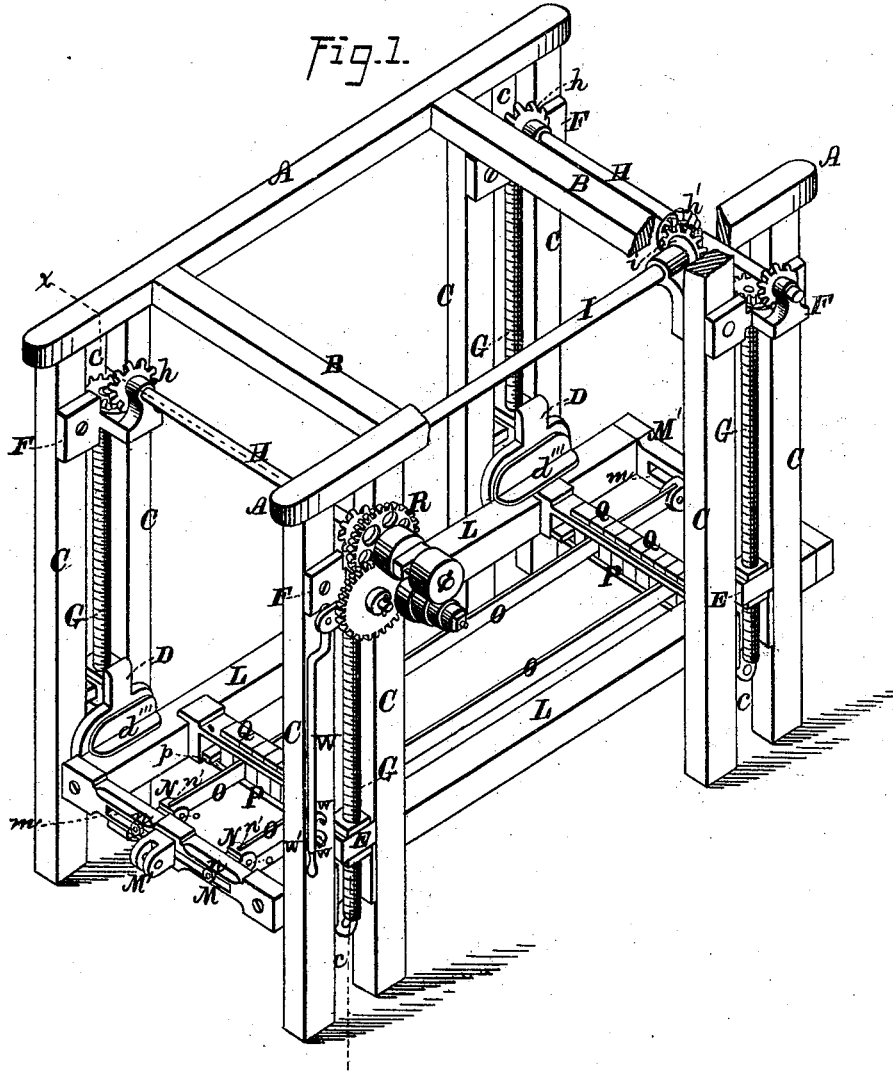

WITNESSES=
Jack Hutchinson
H. S. Hazard

INVENTOR.
W. C. Huffman, by
Orindle and Co. his Attys

W. C. HUFFMAN.
STONE-SAWING MACHINE.

No. 180,344.

Patented July 25, 1876.

Fig. 2.

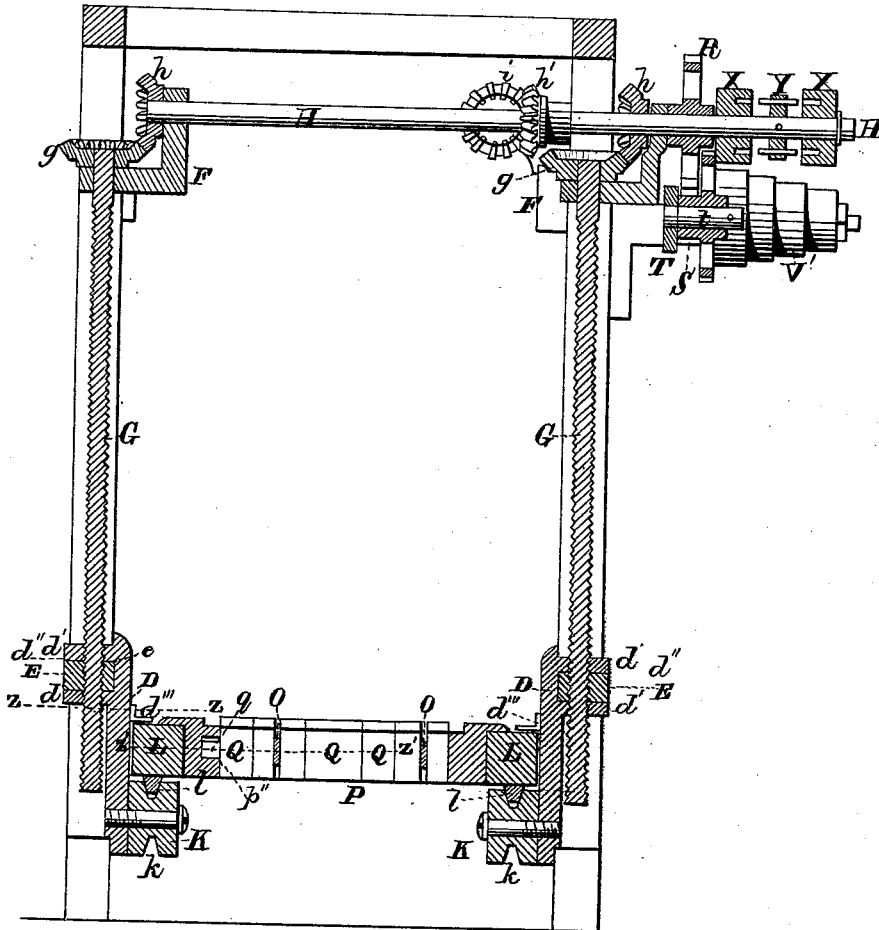

WITNESSES=
Jas. Hutchinson.
H. C. Hazard.

INVENTOR.
W. C. Huffman, by
Prindle and Lo, his Attys

W. C. HUFFMAN.
STONE-SAWING MACHINE.

No. 180,344.

Patented July 25, 1876.

Fig. 3.

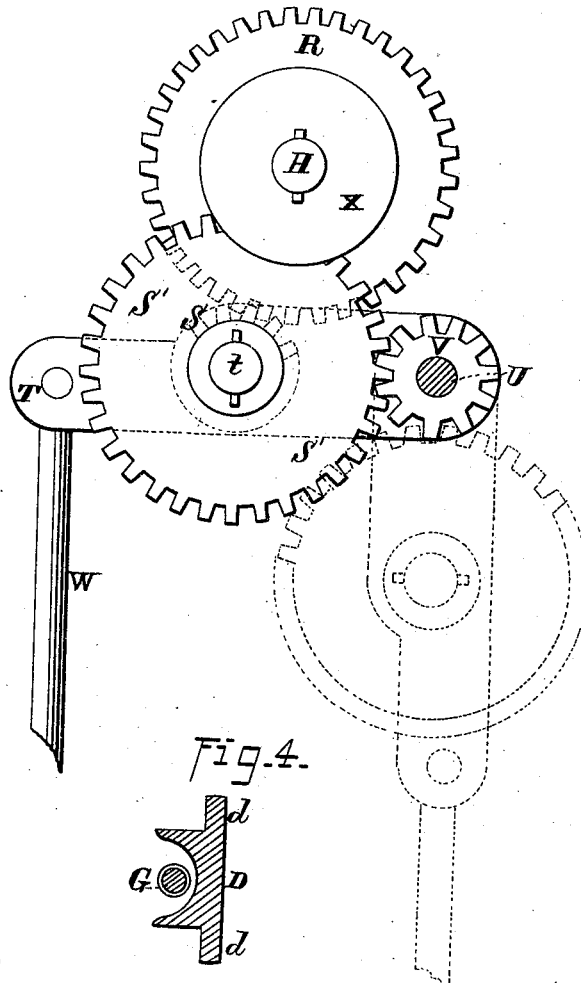

Fig. 4.

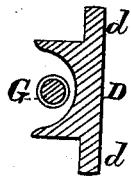
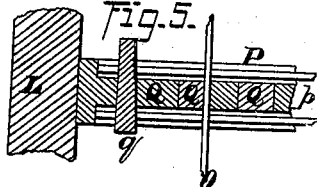

Fig. 5.



WITNESSES=
Jas. Hutchinson.
H. S. Hazard.

INVENTOR.
W. C. Huffman, by
Prindle and his Attys

UNITED STATES PATENT OFFICE.

WILLIAM C. HUFFMAN, OF TOLEDO, OHIO.

IMPROVEMENT IN STONE-SAWING MACHINES.

Specification forming part of Letters Patent No. 180,344, dated July 25, 1876; application filed June 24, 1876.

To all whom it may concern:

Be it known that I, WM. C. HUFFMAN, of Toledo, in the county of Lucas, and in the State of Ohio, have invented certain new and useful Improvements in Machines for Sawing Stone; and do hereby declare that the following is a full, clear, and exact description thereof, reference being had to the accompanying drawings, making a part of this specification, in which—

Figure 1 is a perspective view of my improved machine as arranged for use. Fig. 2 is a vertical section of the same on line *x x* of Fig. 1. Fig. 3 is an enlarged side elevation of the feed-gears, the dotted lines showing the position of parts when said gears are thrown out of engagement. Fig. 4 is a horizontal section of one of the bearings of the saw-frame, and Fig. 5 is a longitudinal section of one of the locking-heads of said frame.

Letters of like name and kind refer to like parts in each of the figures.

The design of my invention is to increase the efficiency of mechanism for sawing stone into slabs or blocks; and it consists, principally, in the means employed for adjusting to and securing in relative position the saws, substantially as and for the purpose hereinafter specified.

It consists, further, in the construction of the saw-frame, and of the guides or bearings within which it moves, substantially as and for the purpose hereinafter shown.

It consists, further, in the means employed for feeding the saw-frame downward when the saws are in operation, substantially as is hereinafter set forth.

It consists, further, in the means employed for raising and lowering the saw-frame to position, substantially as is hereinafter shown and described.

It consists, finally, in the apparatus as a whole, the several parts being constructed and combined to operate in the manner and for the purpose substantially as is hereinafter specified.

In the annexed drawings, A and A represent two rails, which are secured together in parallel lines by means of two cross-bars, B and B, that extend between said rails near their ends. Each end of each rail A is supported

upon two posts, C and C, that are vertical, and are separated by a space, *c*, that has a width substantially equal to the like feature of one of said posts, which space is in a line with the corresponding space *c* upon the opposite side of the frame. Within each space *c* is loosely fitted a block, D, which, upon its inner side, is provided with flanges *d*, that bear upon the inner faces of the posts C, and near or at its upper end has two horizontal lugs, *d'*, that inclose a horizontal parallel space, *d''*, which space receives a nut, E, that loosely fills the same, and is provided with a vertical threaded opening, *e*. Each of said lugs *d'* is provided with an opening that coincides with said threaded opening, but is somewhat larger than the latter, and is plain interiorly. Journalled within a suitable bearing, F, that is secured to and extends between each pair of posts C, near their upper ends, is a shaft, G, which is threaded exteriorly below said bearing, and passes through the threaded opening *e* of the nut E, the arrangement enabling the blocks D to be raised or lowered by the rotation of said shaft. Another shaft, H, is journalled horizontally within and extends between the bearings F and F at one end of the frame, and is provided near each end with a miter-gear, *h*, that meshes with a corresponding gear, *g*, which is secured upon the upper end of each screw-shaft G, by which means the said shafts G and G are compelled to move simultaneously and in the same direction.

In order that all of the screw-shafts may be connected together and caused to move simultaneously, a shaft, I, is journalled within suitable bearings, and extends horizontally between the shafts H and H, and at each end is provided with a miter-gear, *i*, that meshes with a similar gear, *h'*, that is secured upon each of said shafts H and H, by which means the movement of any of said shafts will be communicated to each of the others, and the blocks D raised or lowered uniformly. Upon the inner face of each block D, at its lower end, is journalled a roller, K, which is free to revolve in a vertical plane having a line lengthwise of the machine, and is provided within its periphery with a V-shaped groove. The rollers K sustain a saw-frame, which is composed of two side rails, L and L, that are

arranged in parallel lines, and are connected together at their ends by means of two bars, M and M', commonly termed the "head" and "tail" blocks. Said frame has such width as to enable it to move freely between the blocks D, and is held in lateral position by means of a V-shaped bar, l, that is secured upon the lower side of each rail L, and fits into the groove in the contiguous roller K. The head and tail blocks M and M', respectively, are each provided with a longitudinal horizontal slot, m, and within the same are fitted two or more blocks, N, that are each threaded upon its outer end, and said end provided with a nut, n, while at the inner end of each of said blocks is formed a vertical slot, n', which receives and contains one end of a saw, O. A pin, o, passing transversely through said saw and said block end, confines the former within the latter, in the usual manner.

By loosening the nuts n, the saws O can be adjusted laterally, after which, by tightening said nuts, said saws will be tautened and fitted for use.

In order that the relative positions of the saws O may be insured, and such positions easily and quickly changed, a bar, P, extends between the rails L and L, and at its ends is provided with outward-extending flanges, which embrace the upper and lower sides of said rails, and enable said bar to be moved to any point between the head and tail blocks. Each bar P is provided with a longitudinal horizontal opening, p, for the passage of the saws, and has a longitudinal vertical opening, p', within which latter are fitted a number of T-shaped blocks, Q, that fill said opening transversely, and have different thicknesses.

The blocks Q are placed within the opening p', so as to fill the same from end to end, after which a key, q, is inserted within a slot, p'', at one end of the opening p', and driven inward, when, bearing against the contiguous blocks Q, it presses the latter and the remaining blocks firmly against the opposite end of said opening.

By selecting the blocks Q so as to cause them to just fill the spaces between the saws O and O, and between the outer saw and the rear end of the opening p', the keying up of said blocks will not change the adjustment of said saws, but will prevent the latter from moving when so adjusted.

A lug, d''', secured upon the inner side of each bearing-block D, and extending outward over the rail L, prevents the saw-frame from being moved from off the bearing-rollers, while a suitable pivotal lug, m', that is secured upon the outer face of the head-block M at its longitudinal center, furnishes a means for connecting a pitman with said frame.

In order that the saws may be fed downward at any desired speed, one end of one of the shafts H is extended outward, and upon the same is secured a spur-gear, R, which meshes with, and receives motion from, a pinion, S, that is journaled upon a stud, t, which

stud is secured within, and extends outward from, a bar, T, that is pivoted at one end upon a second stud, U, which extends laterally outward from the side of the frame.

Upon the outer face of the pinion S is secured a gear-wheel, S', which meshes with, and receives motion from, a pinion, V, that is secured upon the inner end of a cone-pulley, V', which latter is journaled upon the stud U.

As thus arranged, the rotation of the pulley V' will, through the pinion V, gear-wheel S', pinion S, and gear-wheel R, be communicated to the mechanism for moving the saw-frame vertically, and cause said frame to descend, the velocity of such descent being governed by the speed imparted to said pulley, and being easily and quickly varied by changing the driving-belt from one pulley to a larger or smaller pulley.

As the mechanism described would not operate with sufficient speed to enable the saw-frame to be raised to admit work, and then lowered to place, the outer end of the lever or bar T is adjusted vertically, so as to cause the feed-gearing to mesh with, or be removed from, engagement with the gear R by means of a bar, W, that is pivoted at its upper end to the outer end of said lever, and, extending downward, is provided with two hook-shaped projections, w, that may be caused to engage with a pin or stud, w', which projects laterally outward from one of the posts C.

When the bar W is raised until the lower projection w can be passed over the stud w', the feed-gearing is in engagement with the raising and lowering mechanism; but if said bar be dropped until the upper projection engages with said pin, said feed-gearing will have no connection with said mechanism.

Two loose pulleys, X and X, are journaled upon the shaft H, outside of the gear-wheel R, and are arranged to move lengthwise of said shaft, so as to enable either to be thrown into engagement with a clutch, Y, that is secured upon said shaft between said pulleys.

The pulleys X are driven by belts in opposite directions, and when the feed-gearing is thrown out of engagement, and either of said pulleys caused to engage with the clutch, the raising and lowering mechanism will be set in motion, and the desired change in the vertical position of the saw-frame will be speedily effected.

The machine described is simple in construction, positive in its movements, and can be operated with a less number of attendants than any heretofore constructed.

Having thus fully set forth the nature and merits of my invention, what I claim as new is—

1. In combination with the saws O, the bars P and P, each provided with a vertical and a horizontal groove, p and p', respectively, and a slot, p'', at one end of said groove p', the blocks Q, inserted within said groove p, between and upon each side of said saws, and the tightening-wedge q, fitted into said

slot, substantially as and for the purpose specified.

2. In combination with the rails L of the saw-frame, provided each upon its lower side with a V-shaped bar, *l'*, the blocks D, arranged to slide vertically within the opening *c* within the main frame, and having upon its inner face a journaled roller, K, that has a V-shaped peripheral groove, and the lug *d'''*, which projects over said rail, substantially as and for the purpose shown.

3. In combination with the saw-frame, the vertically-moving blocks D, having the horizontal space *d''*, the nut E, fitted into said space, the vertical screws G, the shafts H and I, and the miter-gears *h*, *h'*, *g*, *i*, and *i*, substantially as and for the purpose set forth.

4. In combination with the raising and lowering mechanism described, the gear-wheels R and S', the pinions S and V, the bar T, provided with the stud *t*, the stud U, the cone-pulley V', the bar W, having the hooked pro-

jections *w*, and the pin or stud *w'*, secured within, and projecting from, the main frame, all constructed and arranged to operate substantially as and for the purpose shown and described.

5. In combination with the raising and lowering mechanism described, the pulleys X, journaled upon the shaft H, and the clutch Y, secured upon said shaft between said pulleys, substantially as and for the purpose specified.

6. The hereinbefore-described machine, constructed and arranged to operate in the manner and for the purpose substantially as shown.

In testimony that I claim the foregoing I have hereunto set my hand this 23d day of June, 1876.

WM. C. HUFFMAN.

Witnesses:

GEO. S. PRINDLE,
WILLIAM FITCH.