

Z. B. SIMS.
HORSE-POWER PRESS.

No. 180,381.

Patented July 25, 1876.

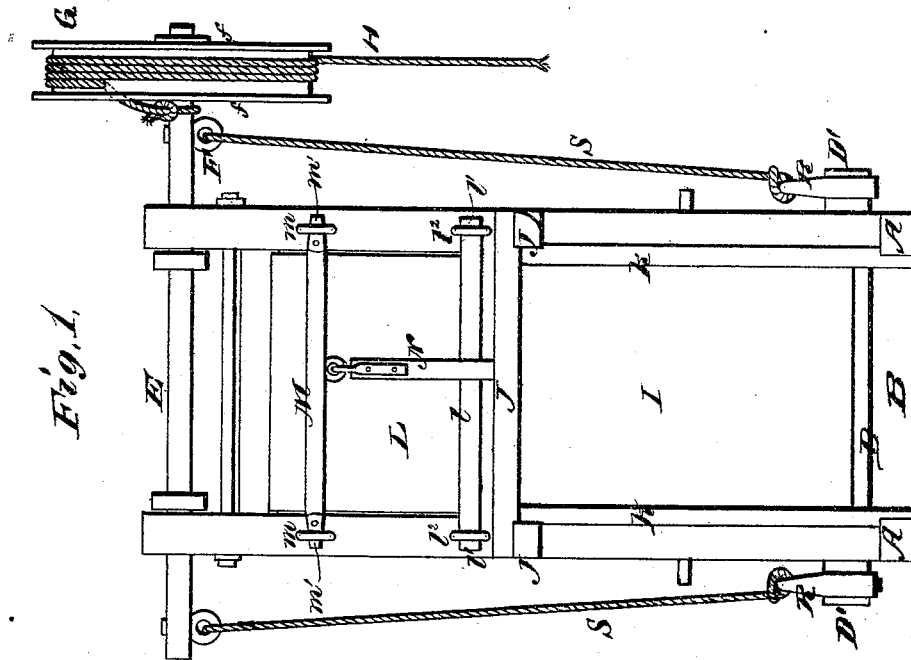
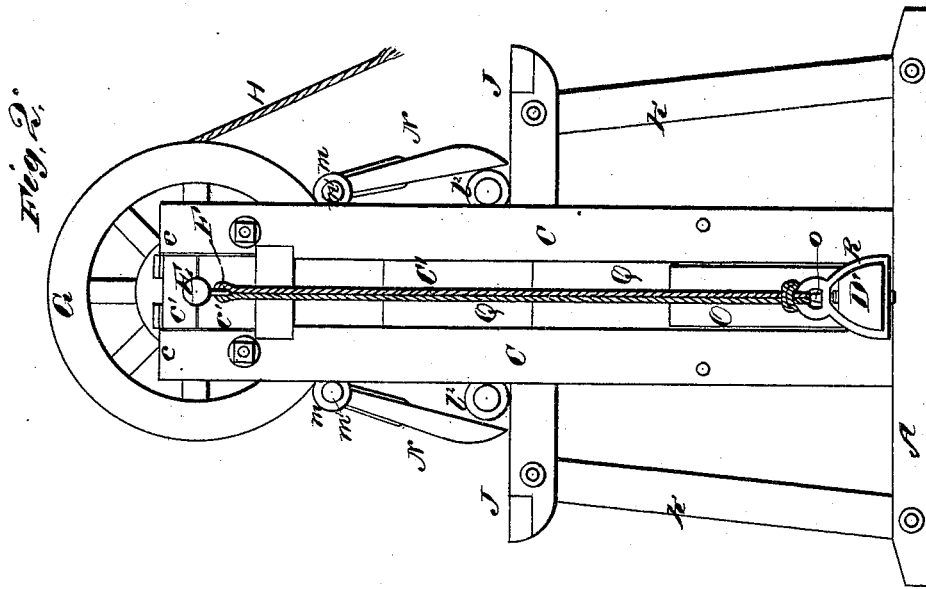

WITNESSES
E. H. Bates
George E. Wham.

INVENTOR
Zachariah B. Sims.
Chipman, Noone & Co.
 ATTORNEYS
By Gilmore, Smith & Co.

Z. B. SIMS.
HORSE-POWER PRESS.

No. 180,381.

Patented July 25, 1876.

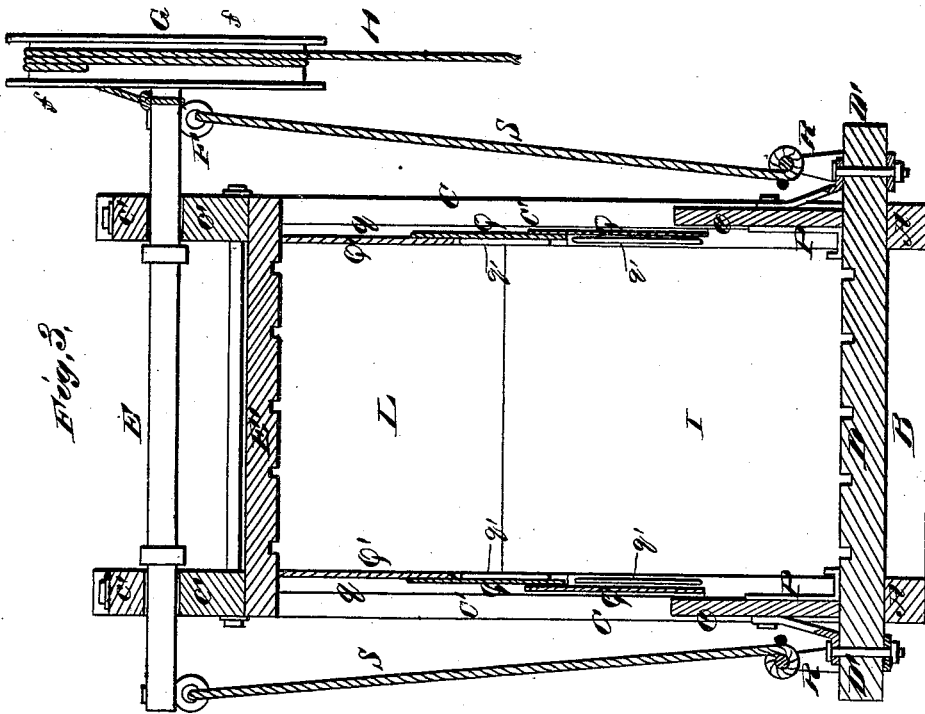
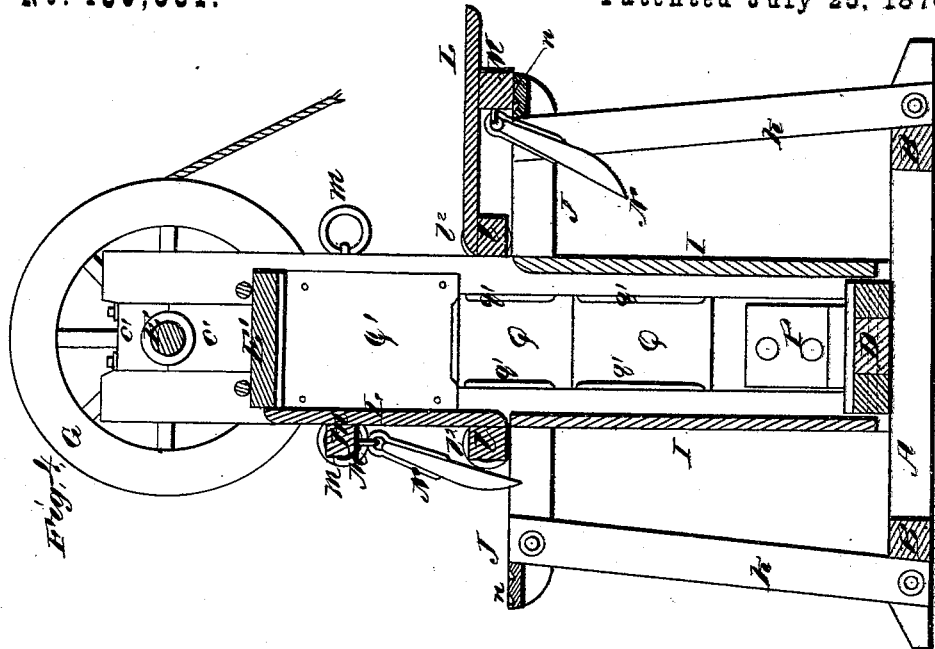

WITNESSES
Chas. H. Bates
George C. Uphaul,

INVENTOR
Zachariah B. Sims.
Chipman, Nooner & Co.
 ATTORNEYS
by Gilmore & Smith & Co.

Z. B. SIMS.
HORSE-POWER PRESS.

No. 180,381.

Patented July 25, 1876.

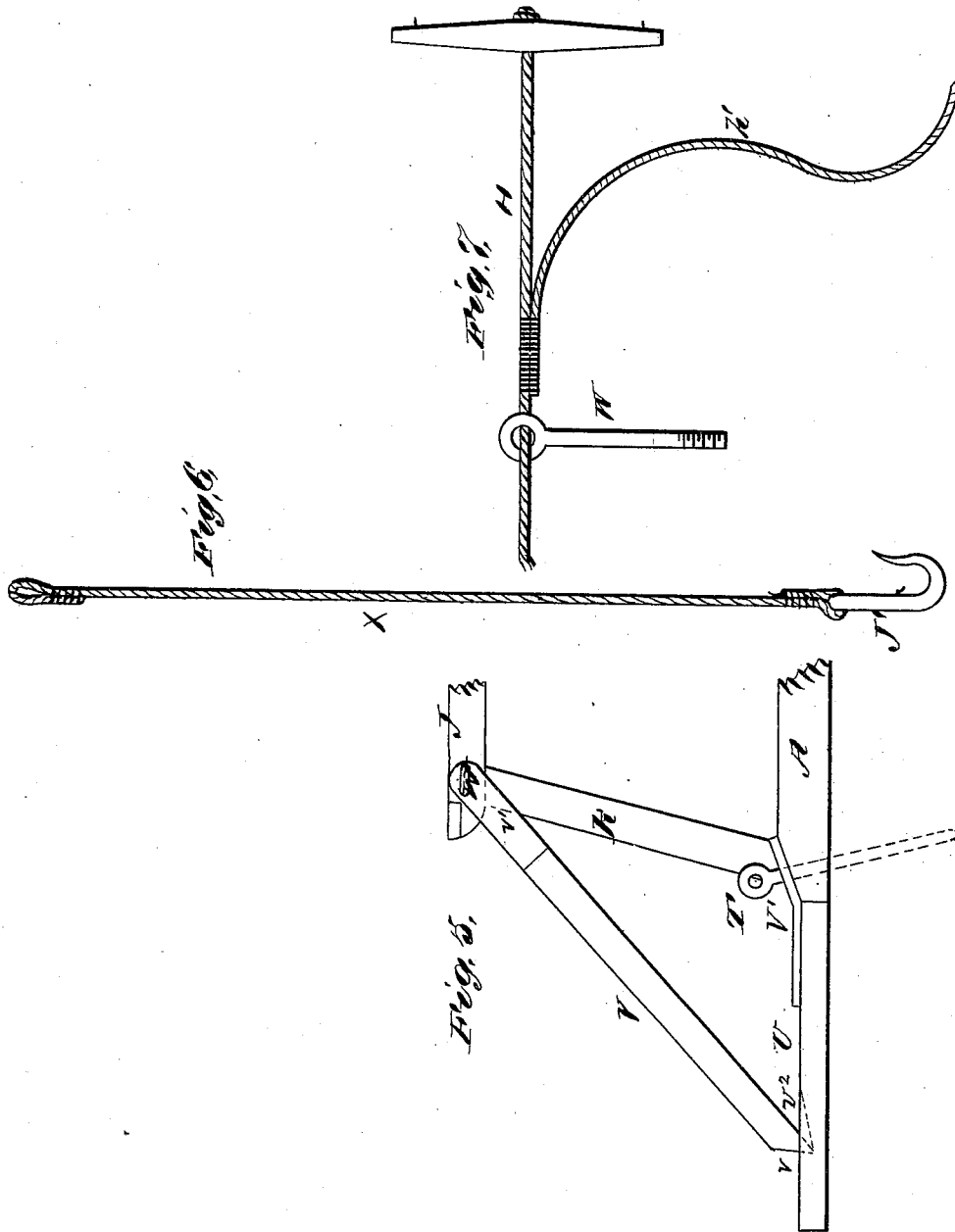

WITNESSES
E. H. Bates
George E. Upham.

INVENTOR
Zachariah B. Sims.
Chipman Abner & Co.
by Gilmore, Smith & Co. ATTORNEYS

UNITED STATES PATENT OFFICE

ZACHARIAH B. SIMS, OF BONHAM, TEXAS.

IMPROVEMENT IN HORSE-POWER PRESSES.

Specification forming part of Letters Patent No. 180,381, dated July 25, 1876; application filed June 10, 1876.

To all whom it may concern:

Be it known that I, ZACHARIAH B. SIMS, of Bonham, in the county of Fannin and State of Texas, have invented a new and valuable Improvement in Horse-Power Presses; and I do hereby declare that the following is a full, clear, and exact description of the construction and operation of the same, reference being had to the annexed drawings, making a part of this specification, and to the letters and figures of reference marked thereon.

Figure 1 of the drawings is a representation of a front elevation of my horse-power press, and Fig. 2 is an end view. Fig. 3 is a longitudinal vertical sectional view of the same, and Fig. 4 is a transverse vertical sectional view. Figs. 5, 6, and 7 are detail views thereof.

This invention relates to horse or other power presses for cotton, hay, and other compressible materials; and the nature of my invention consists in a reversible stay-brace; in a series of sliding plates, which fill the space between the main standards; in an arm hung to each one of the side doors, regulating the opening of such doors; and in auxiliary devices which will be hereinafter particularly described.

In the accompanying drawings, A A designate the longitudinal beams or sills, and B B designate cross-bars, which constitute, when taken together, the bed-frame of the device. On each sill A are rigidly secured vertical standards C C, leaving between them, over the middle of sill A, a space, C', which forms a guideway for extension D' on the end of follower D. The four standards C are connected near their upper ends by rectangular top piece or head E'. The space above such platform and between the tops c c of each pair of said standards is filled by detachable bearing-sections c' c', in which is journaled cylindrical shaft E. This shaft E is provided at each end with a detachable eyebolt, F, and is adapted to carry double-flanged wheel G. I I are housings of boards attached to the main standards C C, and forming the sides of the press. J J are platform-frames attached to standards C C, and supported by detachable standards K K. Their office is to support doors or shutters L L, when said doors are opened to allow the press to be filled with cotton, hay, or other

compressible material. These doors are hung by trunnions l' l' of cross-bars l l at the bottom of said doors to loops or staples l'' l'' fixed in standards C C. When closed, doors L L are fastened by vibratory rings m m, which are pivoted to said standards, and which catch over projecting metal-shielded ends m' m' of upper cross-bars M, fixed in each one of said doors. On the under side of said cross-bar M is hung a prop, N, adapted to engage with notches n n on the upper side of platform-frame J, so as to hold the door at any desired inclination. Follower D is adapted to move vertically in guideways C', and is provided near either end with a rigid vertical slide, O, which may be braced by rod o, and closes the lower part of guideway C'. At the junction of slide O with follower D I attach a flanged angular piece of metal, P, which engages with and carries upward independent slides Q Q. These slides Q move in guideways formed partly by grooves in standards C C, and partly by rods or long staples q' q', fixed to said standards. The bottoms of these grooves may be formed of small pieces of metal or bolt-heads. As follower D is raised, slides Q Q pass one another somewhat after the manner of tubes in a telescope. As the follower D descends, they fall to their former positions. The upper parts of guideways C C are closed by fixed inner plates Q'. By this construction no opening is left for the escape of the material undergoing pressure, and there is no impediment to the rise and fall of follower D. I prefer to make this follower of several pieces, bolted together. Each extension D' of said follower is hung in stirrup R by a rope, S, from eyebolt F on shaft E. Said shaft being rotated one way, ropes S are wound on shaft E, and follower D ascends. When the rotation is reversed, the ropes S unwind, and the follower D descends. Or, the rope being first wound by hand, the operation may be reversed. I prefer an endless rope, looped to stirrup R, and having its two parts connected nearly all the way to eyebolt F.

T T are spikes, which pass through the ends of sills or beams A A, and hold the same to the ground. One of these spikes also serves to hold in position perforated plate V', rigidly attached to extension U, which extension is

provided with a notch, v^2 , for receiving the pointed end v of brace-bar V. The other end of said brace-bar is provided with a flat metal tip, v^1 , perforated to allow the passage of a screw-threaded prismatic eyebolt, W, which serves to hold the brace-bar V to the platform-frame J and standard K. This attachment is effected by simply removing the bolt which connects those parts, and substituting eyebolt W.

As both ends of the apparatus are constructed substantially alike, the above-described bracing-extension may be reversed, so as to sustain either end; or it may be duplicated, so as to sustain both ends, without departing from the spirit of my invention.

Eyebolt W also serves as a guide for actuating rope H, to the end of which a whiffletree is attached, to receive the draft of the horse; also, a short rope, h' . The use of this rope h' is to fasten the main rope H to a post or other convenient object when the cotton or hay has been sufficiently pressed.

The horse is then detached, and hitched to rope X X, which terminates in hooks J' J', that are adapted to grapple with the pressed bales when the doors L L are opened to admit them. These bales are then easily drawn out.

The object of making doors L adjustable to different inclinations is to enable the upper part of the press to be filled with cotton or hay, &c., without allowing any of such material to escape below, as it might if the door remained wide open during the entire process of filling.

Wheel G may be arranged on either end of shaft E, and may operate by turning in either direction. It is preferably constructed with flanges $f f$ on either edge of its periphery, between which flanges the rope H lies when it is wound about the wheel. Said rope may be attached to the said periphery of the wheel; but I prefer to attach it to the shaft E, near the end thereof, and to pass it through said

periphery from the inside to the outside, as shown.

The under side of the head of the press and the upper side of the follower are provided with corresponding lateral or longitudinal grooves.

What I claim as new, and desire to secure by Letters Patent, is—

1. A press-frame, provided with a reversible brace-bar, adapted to support either end of said press-frame, substantially as and for the purpose set forth.

2. The combination of bolts T, extension U, notched at v^2 , brace-bar V, and bolt W, substantially as and for the purpose set forth.

3. In a cotton or hay press, the eyebolt W, adapted to serve both as a fastening for brace-bar V, and as a guide for rope H, substantially as set forth.

4. Follower D, provided with rigid slide O and angular flanged plate P, substantially as and for the purpose set forth.

5. In a press for hay or cotton, slides Q Q, adapted to close at all times the guideway between the main standard, though allowing the vertical movement of the follower in pressing, substantially as set forth.

6. The combination of slides Q Q, plate Q', recesses or grooves $q q$, and long staples $q' q'$, substantially as set forth.

7. In a hay or cotton press, two removable windlass-ropes, looped to removable stirrups bolted to extended ends of follower D, and operated through eyes of the shaft E, in combination with the shaft E and follower D, substantially as and for the purpose described.

In testimony that I claim the above I have hereunto subscribed my name in the presence of two witnesses.

ZACHARIAH B. SIMS.

Witnesses:

C. E. BROWN,
F. D. PINER.