

M. W. SPAULDING.
BUTTER-PACKAGE.

No. 180,389.

Patented July 25, 1876.

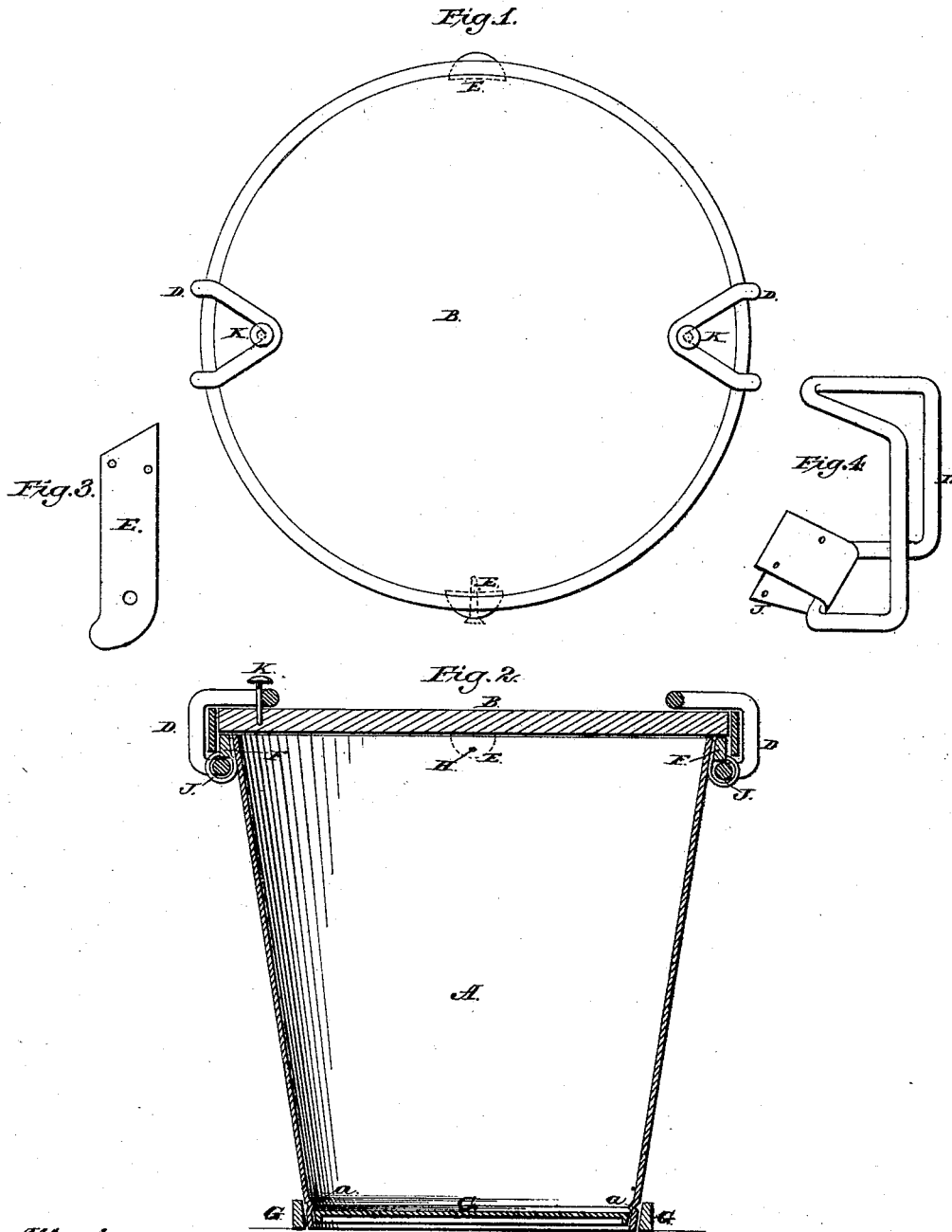

Attest:
A. J. Smith
C. C. Van Waters

Inventor:
M. W. Spaulding

UNITED STATES PATENT OFFICE.

MARK W. SPAULDING, OF RENSSELAER FALLS, NEW YORK.

IMPROVEMENT IN BUTTER-PACKAGES.

Specification forming part of Letters Patent No. **180,389**, dated July 25, 1876; application filed June 1, 1876.

To all whom it may concern:

Be it known that I, MARK W. SPAULDING, of Rensselaer Falls, St. Lawrence county, New York, have invented a new and useful Improvement in Butter-Packages; and I do hereby declare that the following is a full, clear, and exact description thereof, reference being had to the accompanying drawings, and to the letters of reference marked thereon, making a part of this specification.

My invention relates to the construction of the upper portion of the package and the fastenings of the cover.

In the annexed drawings, which make a part of this specification, Figure 1 is a plan view of the top of the package. Fig. 2 is a vertical cross-section of the package. Fig. 3 is a detached perspective view of the spring-fastening. Fig. 4 is a detached perspective view of the hinged fastening.

Like letters refer to like parts.

In the figures, A represents a metal butter package, can, or tub; B, the cover, and C the bottom, to the same. D D are the hinged fastenings; E, one of the spring fastenings or catches, any number of which, as well as of the hinged fastenings, may be employed. F and G are wooden or metallic hoops, surrounding the body of the can for protecting it from injury. F also affords a fastening to the pin or hook H, which engages with the spring-catch E, and for the loop of the sheet-metal piece J, which secures the fastening D to the body of the package. G, by projecting below the bottom, affords a convenient place for grasping the can in handling, and also it will to some extent keep the can-bottom from the ground, and prevent it from getting wet or rusted. It is secured in place by nails or rivets passing through that portion of the body of the can which projects below the metal bottom.

The body of the can has a bead, *a*, made by creasing. The metal bottom C has its edges turned downward. It is then pressed upward to the bead, where it is soldered, as seen. A flange is turned over the upper hoop to hold it from being forced upward by strains upon the fastenings D and E. Nails or rivets are also driven from the inside through the body of the can into this hoop. This hoop holds the can in circular form while being packed with butter, so that the cover

will fit easily, and protects the body of the can in transportation.

The fastening D is preferably made of wire, and is secured by a band or loop of sheet metal passed through its lower end, and nailed or riveted on the inside of the hoop F before the hoop is placed upon the can. This construction permits the fastening to swing back from the cover to allow the latter to be removed. This fastening is held firmly to the cover during transportation by the nail K, as shown.

The spring-fastening E is preferably made of sheet metal, and perforated at its lower end to receive or catch upon the stud, pin, or hook H, attached to the upper hoop. It is nailed to the head inside of the hoop encircling the head.

By the above arrangement a package is produced that is easily handled, quickly and securely fastened for transportation, protected from injury during shipment, and with a good surface upon the cover, free from cleats or attachments of any kind to hinder marking a shipping-address thereon. The spring-catches, besides assisting in holding the cover during shipment, afford a readily-operated fastening to the retailer.

I am aware that a package having a hoop which extends below and supports the bottom is not new, and a lid fastened on by two short levers meeting in the center and secured by an inverted U-shaped button, is not new; hence I do not claim such as my invention.

Having thus fully described my invention, what I desire to secure by Letters Patent is—

1. The combination, with a butter-package having a metallic body, of the wooden hoop F, adapted to preserve the cylindrical form of the metal body, and furnish stays for the metal eyes to which the fastening-loops D are secured.

2. The fastenings E, attached and operating as set forth.

3. As a new article of manufacture, a butter-package consisting of the body A, cover B, bottom C, fastenings D and E, and hoops F and G, as and for the purposes set forth.

M. W. SPAULDING.

Witnesses:

A. T. SMITH,
C. C. VAN WATER.