

K. J. ENSMINGER.
MARBLE POLISHING MACHINE.

No. 180,707.

Patented Aug. 8, 1876.

Fig. 1.

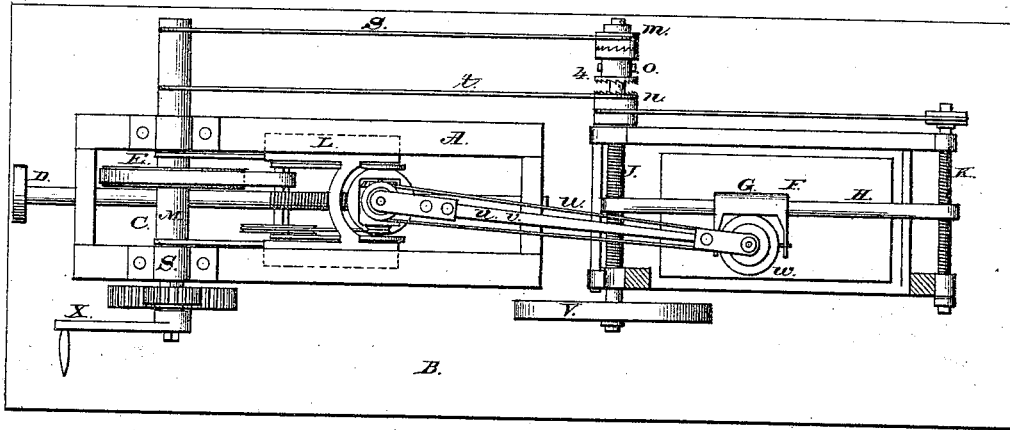

B.

Fig. 2.

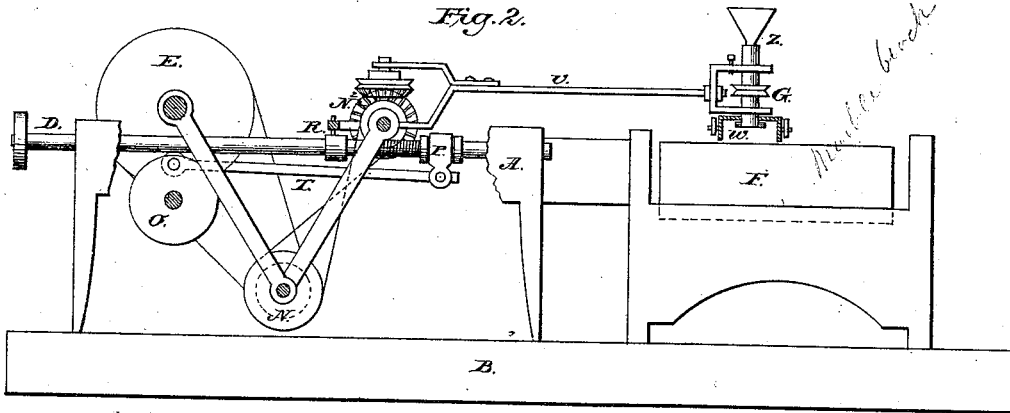

B.

Fig. 3.

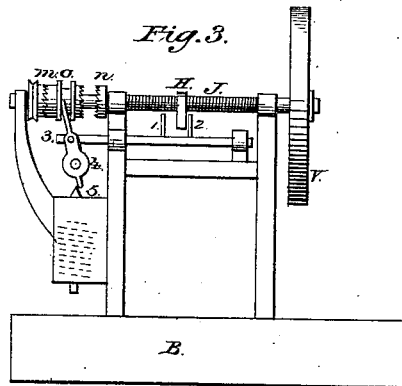

B.

Attest:

O. H. Genschel
B. Pickering

Inventor:

K. J. Ensminger.

UNITED STATES PATENT OFFICE.

KOSSUTH J. ENSMINGER, OF PORTLAND, INDIANA, ASSIGNOR OF ONE-HALF HIS RIGHT TO JOHN J. WINTERS, OF SAME PLACE.

IMPROVEMENT IN MARBLE-POLISHING MACHINES.

Specification forming part of Letters Patent No. 180,707, dated August 8, 1876; application filed June 2, 1876.

To all whom it may concern :

Be it known that I, KOSSUTH J. ENSMINGER, of Portland, State of Indiana, have invented an Improved Marble-Polishing Machine, of which the following is a specification :

The object of my invention is to operate the rubber or polisher so that it shall have a continuously-varying movement, combining the longitudinal, lateral, and rotary movements, the horizontal and rotary movements being given from an adjustable sliding head, and the lateral from a traversing-bar carried by threaded shafts operated by suitable mechanism.

Figure 1 is a top view of the polishing-machine. Fig. 2 is a side elevation of the same, having portions cut away to more clearly illustrate the interior. Fig. 3 is a cross-section of the machine immediately in front of shaft J.

A represents the frame, which should be continuous to the right-hand end, and embrace the entire parts of the machine. As the frame was constructed in two parts, the same are attached to a common base, B. The shaft M has bearings near the left-hand end of the frame. Slide-bars are bolted onto the frame, which, with the top of the frame, form grooves for the sliding head L. At the left-hand or front end of frame, and at center cross-bar, is supported the adjusting-rod D. This rod moves within the threaded nut R, which is connected to the sliding head, and by turning the same the sliding head is moved backward and forward. P is a swivel-joint near the right-hand end of the rod, and the bar T connects this joint to the wheel O. (See Fig. 2.) The shaft M has upon it, external to the frame, a pinion, S, and within the frame a band-wheel, E, and without the frame, on the opposite side to wheel S, a pulley for the bands *s* and *t*. Directly beneath this shaft is supported a shaft, upon which, external to the frame, is secured the spur-wheel X and the wheel O. Four arms—two supported from the shaft M and two from the sliding head L—give support to a shaft, having upon it a pulley for the band of the wheel E, and a grooved pulley for the band which runs over a pulley, N², in the sliding head L. The sliding head supports a pivotal frame, circular in form, with recesses

for the grooved pulley on the near or left-hand side, and a miter-wheel on the farther or right-hand side, which gears into its fellow, supported by a vertical shaft secured to the center of the pivotal frame. Over the miter-wheel is a grooved pulley, which pulley is connected by the band *u* to the pulley on the shaft Z. The connecting-arm *v* is attached to the vertical shaft of the pivotal frame, and on which it freely oscillates. On the opposite end of this arm is supported a hollow shaft, Z, the lower end of which extends into the interior of the case *w*, and has two projections to engage the circular rubbers, which may be used within the case. This case is pivoted to the arms of the slide G, which is notched, and moves freely over the traversing rod H. The rubbers are made of cast-iron, wood, or other suitable material, circular in form, and notched on the upper inner side to receive the projections on the shaft Z; and by this means the rubber is made to rotate within the case. At the top of the shaft is a funnel to convey the sand or other material to the surface of the marble block F. This has a support within the frame. The weight of the shaft alone rests upon the rubber; and to add to the pressure a spring may be used (see Fig. 2) to add the weight of the arm and case to the rubber.

Other means than that of a spring may be used to furnish weight to the rubber.

The device for reversing the lateral motion is represented at Fig. 3, the two pulleys *m* *n* having notched faces to engage the sliding clutch *o*, which has a feather moving within a groove of the shaft J, by which it is rotated when engaged by either of the loose pulleys. These pulleys are turned in opposite directions by the bands from the main shaft. The pulley *n* has a band running onto the pulley on the shaft K. This connection causes the two shafts J and K to rotate together, the thread of each carrying the traversing rod H to or fro as the direction is given by the shifting-clutch. At 3, Fig. 3, is represented a rod, through the movement of which the clutch is moved first to engage one pulley and then the other. In this rod is a series of holes, in which the pins 1 and 2 are inserted. These pins are so situated that the head or down-

ward projection of the traverse-rod H engages them, and thereby carrying the pivotal arm 4, which carries with it the clutch. That the movement may be perfect, a rod, 5, its upper end terminating in an obtuse angle, and being supported from beneath by a spiral spring, bears against the lower end of this lever, and when the said lever is carried by the point the reaction of the spring throws the clutch so as to engage the opposite pulley, and thus is the action reversed, causing the rubber to be moved first in one direction and then in the opposite. To regulate the lateral movement, the pins are changed as required.

V is a balance-wheel to prevent the device from stopping on the center at the point of change.

A crank is attached to the main shaft, and, when driven by power, a pulley will take the place of the crank. The motion is from the main shaft to the vibrating shaft beneath, from this to the shaft of the pivotal frame, and from this to the rubber resting on the block of marble. The appliances effecting these several movements produce the rotary and longitudinal movements of the rubber on the marble slab. The rod D forms the connection between the sliding frame and the reciprocating arm, and by turning the same the rubber is carried to any point on the slab desirable.

In regard to the operation, after what has been presented, it is only necessary to add that the usual material known to experts—sand, grits, pumice, &c.—is passed into suitable rubbers attached to the shaft, through the orifice within the same. The support to the rubber-case is such that the marble may be polished at an angle deviating from a horizontal plane, and have a like deviation longitudinally.

What I claim as my invention is—

1. The sliding frame L, with its operating parts, connecting-arm *v*, rubber-case *w*, band *u* about suitable pulleys, shaft Z, and adjusting-rod *d*, the whole combined to produce a rotary and reciprocating movement, in the manner substantially as and for the purpose set forth.

2. The combination of the traversing rod H, the shafts J and K, the armed guide G, rubber-case *w*, rod 3, clutch *o*, and pulleys *m* and *n*, substantially as set forth, to give an alternate lateral movement to the said rubber-case, for the use specified.

KOSSUTH J. ENSMINGER.

Witnesses:

P. H. GUNCKEL,
B. PICKERING.