

P. A. WHITNEY.
BENDING-MACHINE.

No. 180,810.

Patented Aug. 8, 1876.

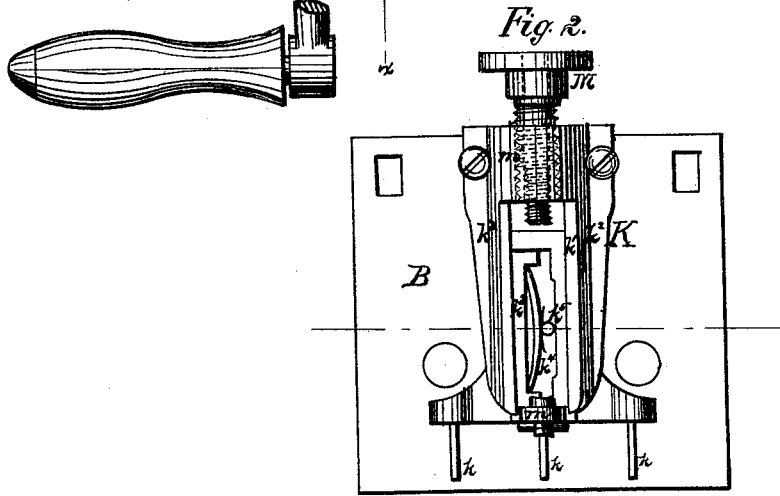
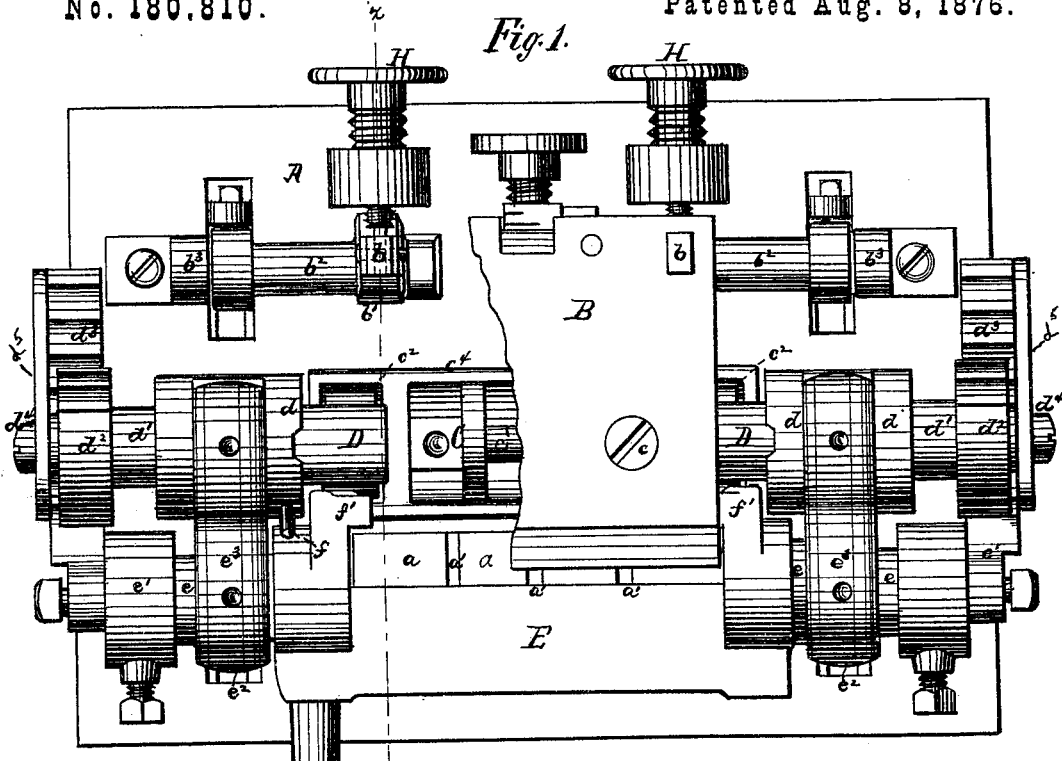

Witnesses:

Theodore Moxter.
B. B. Clark

Fig. 3.

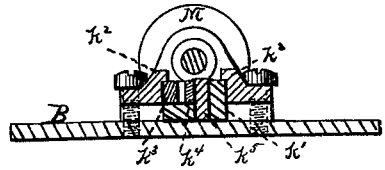

Inventor:

Pardon A. Whitney
By *Wm. H. H. H.*
Atty.

P. A. WHITNEY.
BENDING-MACHINE.

No. 180,810.

Patented Aug. 8, 1876.

Fig. 4.

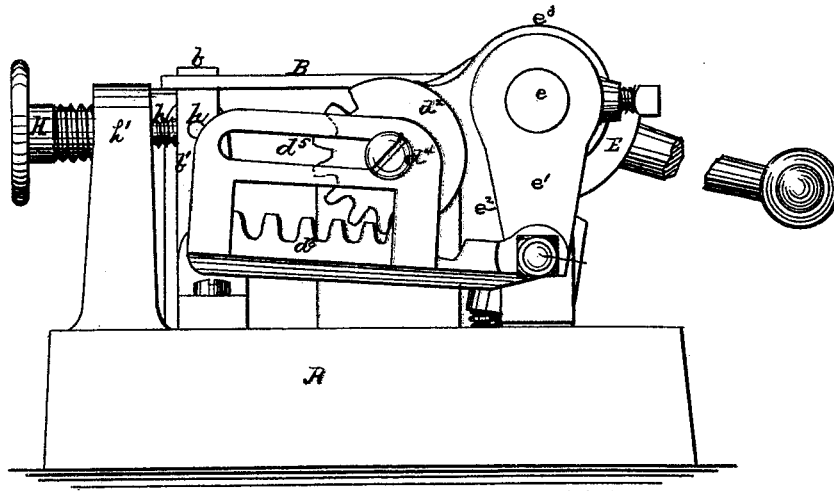
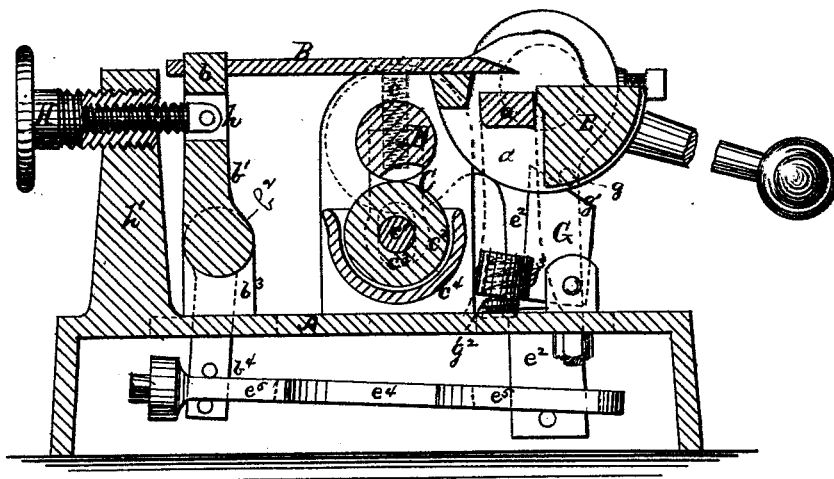

Fig. 5.



Witnesses:

Theodore Weston.

P. J. Schack

Inventor:

Pardon A. Whitney

By Rich. Fitch
Atty

UNITED STATES PATENT OFFICE.

PARDON A. WHITNEY, OF SOUTHLINGTON, CONNECTICUT.

IMPROVEMENT IN BENDING-MACHINES.

Specification forming part of Letters Patent No. 180,810, dated August 8, 1876; application filed May 4, 1876.

To all whom it may concern:

Be it known that I, PARDON A. WHITNEY, of Southlington, Hartford county, in the State of Connecticut, have invented certain Improvements in Machines for Bending and Folding Sheet Metal, of which the following is a full, clear, and exact description, reference being had to the accompanying drawings, forming part of this specification.

My invention relates to a machine for bending or folding the edges of sheet metal by means of a swinging bar working round a blade or folder-edge; and it consists in the specific devices and combinations of parts hereafter particularly set forth, and more fully recited in the claims.

Figure 1 is a plan of a machine embodying my invention. Fig. 2 is an under-face view of the folder-blade, showing the improved gage for setting same. Fig. 3 is a vertical sectional view of the parts shown in Fig. 2. Fig. 4 is a side elevation of the machine; and Fig. 5 is a sectional view of the same on the line *x x*, Fig. 1.

A is the base of the machine. Upon this base is the upright standard *a*, which forms the bed to hold the metal during the operation of bending the edge thereof. This standard has slots *a'* extending across its face, in which the arms of the gage work. B is the folding-blade, the folding-edge of which is arranged over the standard *a*, as shown. The said blade is mounted at its rear side by means of slots engaging tenons *b* on the upper ends of arms *b¹*, which are mounted on the short rock-shafts *b²*, having bearings at *b³* in the rear of the standard. The said blade is also connected by screws *c* to the arms C, which are under the blade, and swing upon the shaft *c¹*, which shaft carries the friction-rollers *c²*, and has slotted bearings at *c³* in posts or standards *d*, as shown. By this means the said friction-rollers, which bear against the cams D, are suspended upon the blade B, and the movement of said cams is then felt by the blade. Upon the shaft *c* is hung an oil cup or box, *c⁴*, preferably divided into compartments, as shown, and partly inclosing the said friction-rollers and the joints of the arms C to the shaft, whereby all drip of the lubricating-oil is avoided. The said cams D work

in bearings in the upper ends of the standards *d* fixed on the base A, and are operated by segmental pinions *d²* fixed on the ends of the cam-shafts *d¹*, said pinions engaging the racks *d³*, which are pivoted to the cranks *e¹* on the ends of the shaft or bearings *e* of the folding-bar E, and which are hung upon the outer ends of the cam-shafts *d¹* by a pin or bolt, *d⁴*, and a long slot, *d⁵*, as shown. The folding-bar E is mounted to turn on bearings *e* in the standards *e²*, which are yoked at *e³* to the cam-shaft, as shown, and which extend through slots to the under side of the base, where they are respectively connected, one on each side, to arms *b⁴* depending from the short rock-shafts *b²*, through slots, to the under side of the base, by means of the rods or yokes *e⁴*, slotted at *e⁵*, as shown. The movement of the folding-bar E is limited in one direction—that is, when it is folded upon the blade B by a pin, *f*, set in the standard *d*, against which the bar impinges, and its movement is limited when unfolded or opened by the pins or projections *f¹*, which catch against the under side of the blade B, and also serve to raise the blade up from the bed *a* to release the sheet metal. The blade is relieved from strain or jar by contact with these pins *f¹* by means of the pins *g* set on the inner face of the standards *e²*, which engage or bear against the beveled or inclined upper edge *g¹* of the arms G, which are pivoted to the base, as shown, and have a coil-springs, *g²*, set in the base, and adjusted under caps *g³*, forming part of the arms G, so that when the bar E is opened the pins *g* will press upon the arms G, thus compressing the coil-springs adjusted thereto.

The folding-blade B is made adjustable, to form either a round or short fold in the sheet metal, by means of thumb-screws H hinged at *h* to the arms *b¹*, and working in standards *h'* fixed to the base A.

My improved gage, as shown in Figs. 2 and 3, is secured upon the under side of the folding-blade B, and has the slide K, carrying upon its forward end the bars *k*, which move in the slots *a'* in the bed-piece *a*, the said slide having the L-shaped projection *k¹* on its upper side, which extends along the slide, and is arranged to move in one of the ways *k²*, and the piece *k³* arranged to move in the opposite way

k^2 , and being held in place by the spring k^4 , which is sustained by the pin k^5 in the slide, as shown. To the forward end of the slide at m is attached a thumb-screw, M, which extends backward over the slide (it being shown broken off in the drawing to disclose the parts beneath it) to and through the nut m' . By means of this construction with the piece k^3 and spring k^4 the gage is relieved from all wear and strain while moved in its ways, and is rendered more firm and durable.

I am aware that Letters Patent have been hitherto granted to me, jointly with another, for a machine for bending and folding sheet metal, and I do not intend to claim herein the parts and combinations of parts therein shown and described. In said machine the folding-bar is made adjustable to form a round or open bend in the sheet metal, and, consequently, the journals or bearings of the said bar are movable; whereas, in the machine herein shown and described the folding-blade is adjustable and the folding-bar is stationary, so that the folding-bar is, at all times during its operation, at the same distance from its bearings on the cam-shaft, thus forming a truer and more uniform turn or fold in the metal, and giving a more solid and durable structure to the machine.

Another advantage in the present machine is that the folding-bar, being stationary in its bearings, is always, when open, in position to receive the sheet metal.

I am aware that the employment of cams to close the blade upon the bed-plate is not new,

and hence I do not claim this broadly, intending to limit my claim to the specific combination of parts which I employ, as herein particularly set forth.

What I claim as my invention, and desire to secure by Letters Patent, is—

1. In a machine for bending and folding sheet metal, the combination of the folding-bar E, yielding standards e^2 , yokes e^3 , camshafts d^1 , and fixed standards d , whereby a uniform distance is at all times preserved between the folding-bar and the camshafts, as described, and for the purpose specified.

2. The combination of the slotted folding-blade B, tenon-arms b^1 , rockshafts b^2 , thumb-screws H, hinged at h to said tenon-arms, and working in standards h' , whereby the said folding-blade is adjustable to the folding-bar, as described, and for the purpose specified.

3. The combination of the folding-blade B, screws c , arms C, friction-rollers c^2 , shaft c^1 , having slotted bearings c^3 , standards d , cams D on shafts d^1 , segmental pinions d^2 , racks d^3 , having slots d^5 working on pins d^4 , cranks e^1 on shaft e , as described, and for the purpose specified.

4. The combination, with the blade B, of the slide K, carrying bars k , ways k^2 , rib k^1 , piece k^3 , and torsion-spring k^4 , together with the thumb-screw M, and nut m' , as described, and for the purpose specified.

PARDON A. WHITNEY.

Witnesses:

MARCUS H. HOLCOMB,
FRANCIS D. WHITTLESEY.