

A. H. ADAMS.
UMBRELLA-SUPPORTS.

No. 180,818.

Patented Aug. 8, 1876.

Fig. 1.

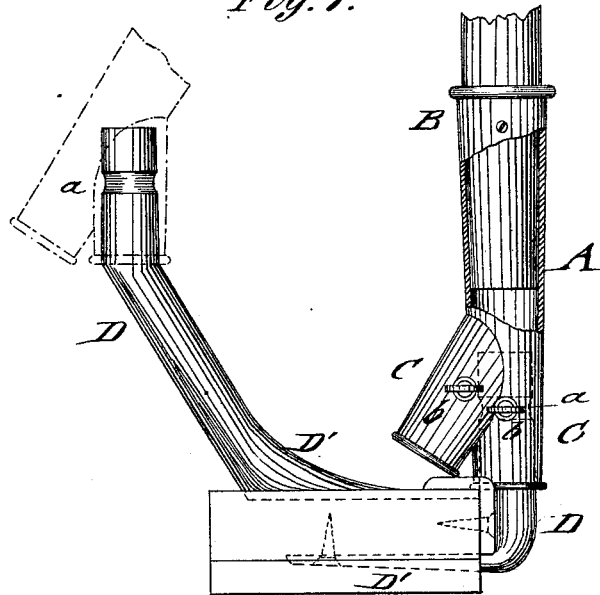
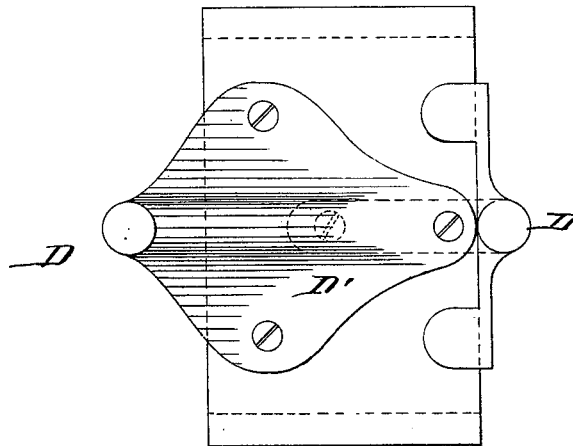

Fig. 2.



WITNESSES:

H. Pydqvist.
John Goethals

INVENTOR:

A. H. Adams

BY

Munniff

ATTORNEYS.

UNITED STATES PATENT OFFICE.

AUGUST H. ADAMS, OF PIQUA, OHIO.

IMPROVEMENT IN UMBRELLA-SUPPORTERS.

Specification forming part of Letters Patent No. **180,818**, dated August 8, 1876; application filed May 16, 1876.

To all whom it may concern:

Be it known that I, AUGUST H. ADAMS, of Piqua, in the county of Miami, and in the State of Ohio, have invented a new and Improved Socket Attachment for Wagon-Umbrellas, of which the following is a specification:

In the accompanying drawing, Figure 1 represents a side elevation, partly in section, of my improved socket attachment for wagon-umbrellas; and Fig. 2 is a top view of the same.

Similar letters of reference indicate corresponding parts.

My invention relates to an improved socket attachment for wagon and buggy umbrellas; and the invention consists of an attachment having a socket for the umbrella-handle at one end and double sockets at suitable angle at the opposite end, to be secured by clamp-screws to a grooved supporting-post attached to the wagon-seat.

In the drawing, A represents the socket attachment, that is preferably made of cast-iron, and screwed firmly, by its upper socket part B, to the handle of the umbrella. The lower end of the attachment A is provided with two or more sockets, C, one in line with the upper one, the others at a suitable angle thereto. The sockets C are fitted to a stationary post,

D, secured by a suitable base-plate, D', to the seat of the buggy or other vehicle. The post D is provided with an annular groove, *a*, into which a clamp-screw, *b*, of each socket C enters, for the purpose of rigidly securing the socket attachment.

When the umbrella is desired to be used in upright position the straight socket is used; but when an inclined position of the umbrella in storming weather is desired, the angular socket is used, and the umbrella then set and applied in the required direction by means of the groove and set-screw. The umbrella may thus, by a cheap and simple socket attachment, be secured in any desired position for protecting against sun and rain.

Having thus described my invention, what I claim as new, and desire to secure by Letters Patent, is—

A socket attachment for wagon-umbrellas, made with a socket for the umbrella-handle at one end and two or more sockets at the other end, at suitable angles to each other, substantially in the manner and for the purpose specified.

AUGUST H. ADAMS.

Witnesses:

J. F. MCKINNEY,
S. S. MCKINNEY.