

D. C. BACON.
FARM-GATE.

No. 180,823.

Patented Aug. 8, 1876.

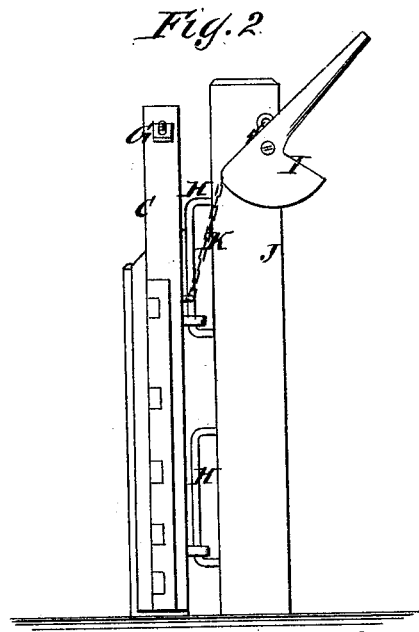
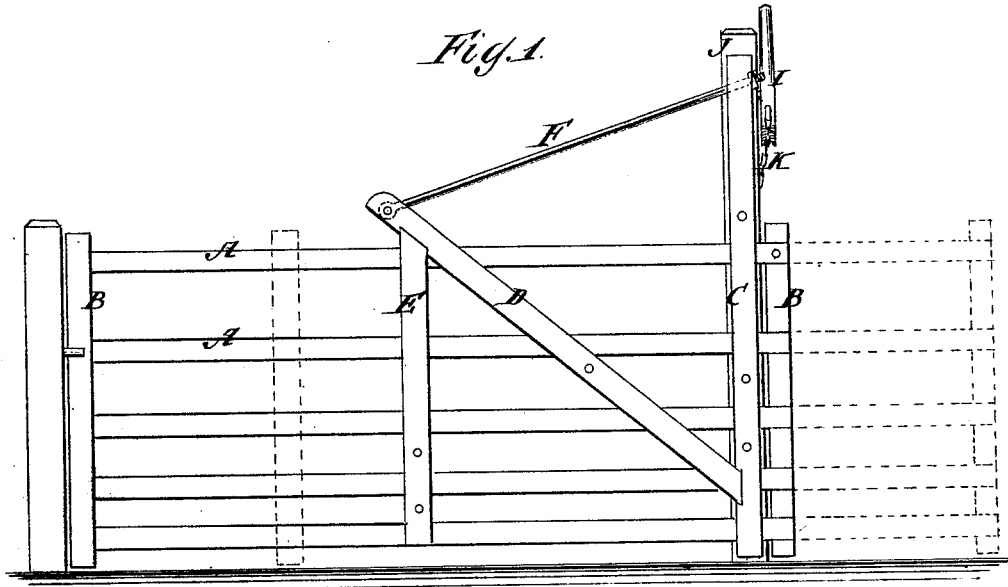

WITNESSES:

E. Woff
John Goethals

INVENTOR:

D. C. Bacon

BY

Munn

ATTORNEYS.

UNITED STATES PATENT OFFICE.

DENNIS C. BACON, OF LITCHFIELD, ILLINOIS.

IMPROVEMENT IN FARM-GATES.

Specification forming part of Letters Patent No. **180,823**, dated August 8, 1876; application filed May 1, 1876.

To all whom it may concern:

Be it known that I, DENNIS C. BACON, of Litchfield, Montgomery county, Illinois, have invented a new and Improved Gate, of which the following is a specification :

The invention consists in hinging the rear post of its frame to the main gate-post, on which it turns by eyes and long staples, as hereinafter described.

Figure 1 is a side elevation of my improved gate, and Fig. 2 is an end elevation.

Similar letters of reference indicate corresponding parts.

A represents the horizontal bars, and B the vertical end bars, of the gate proper. C is a hinged post; D and E, a bracing-frame of double bars, in which the gate is supported; and it is also supported in the post C, so that it can slide open lengthwise, as indicated by the dotted lines.

The frame D E is supported from the top of post C by the tension-rod F, which is secured at the top by a nut, G, by which the

frame is adjusted in case of sags. The post C is hinged to the long staple-pintles H, so that it can be raised high enough to allow hogs and sheep to pass under it, and to swing over snow in winter. A cam-lever, I, is attached to the posts J and connected to gate-post C, by chain K, to raise and lower the gate. A fastening device will be employed to hold the lever down and fasten the gate up when required.

Having thus described my invention, I claim as new and desire to secure by Letters Patent—

The gate A, supported by slotted post C, slotted brace D, and adjusting-rod F, in combination with the post J, provided with the elongated staples H, and the cam-lever I, having flexible connection with gate, all substantially as shown and described.

DENNIS CHAPMAN BACON.

Witnesses:

J. W. BURNS,
JOHN M. FERGUSON.