

W. S. BLUNT & E. BLUNT, Jr.
PUMP.

No. 180,831.

Patented Aug. 8, 1876.

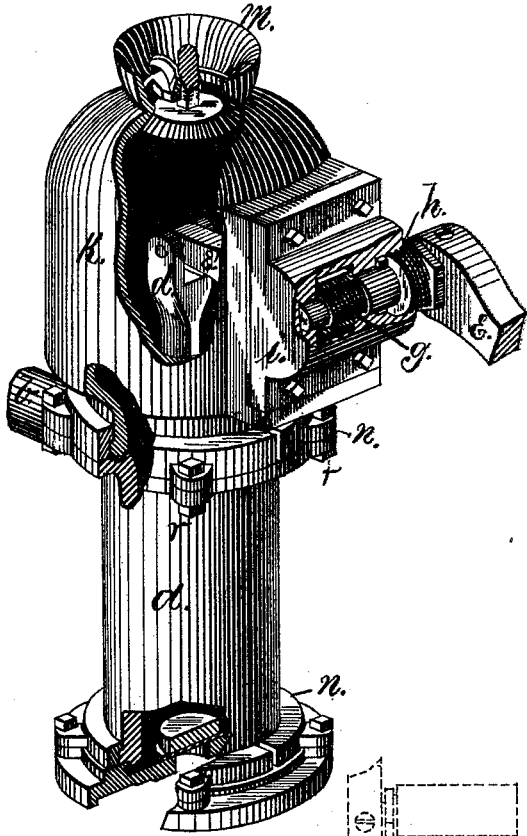

FIG. 1.

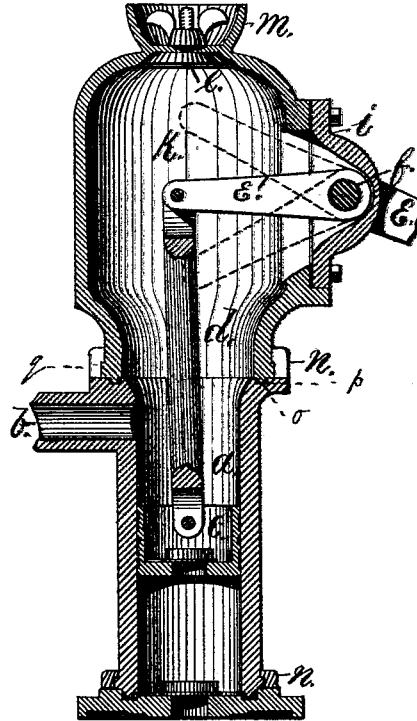

FIG. 2.

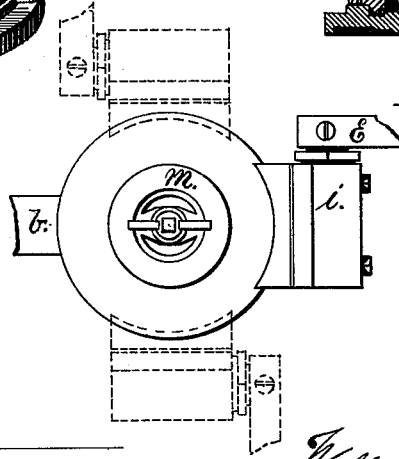

FIG. 3.

WITNESSES.

Augustus Frey

E. M. Leagelle

INVENTOR.

William S. Blunt
Edward Blunt Jr.

UNITED STATES PATENT OFFICE.

WILLIAM S. BLUNT AND EDMUND BLUNT, JR., OF NEW YORK, N. Y.; SAID EDMUND BLUNT ASSIGNOR TO SAID WILLIAM S. BLUNT.

IMPROVEMENT IN PUMPS.

Specification forming part of Letters Patent No. 180,831, dated August 8, 1876; application filed June 2, 1876.

To all whom it may concern:

Be it known that we, WILLIAM S. BLUNT, of the city, county, and State of New York, and EDMUND BLUNT, Jr., of the city, county, and State of New York, have invented certain new and useful Improvements in Pumps; and we do hereby declare that the following specification, taken in connection with the drawings making a part of the same, is a full, clear, and exact description thereof.

Figure 1 is a perspective view of my improved pump, parts of the exterior being shown as broken out so as to allow a view of the interior, and also to show the coupling device by which the air-chamber is secured to the pump-barrel. Fig. 2 is a sectional elevation of my improved pump. Fig. 3 is a top view, showing the positions at which the pump brake or handle may be placed, partly in solid and partly in broken lines.

The object of this invention is to construct a pump which can be used as a common house or lifting pump, and by closing a valve at once convert it into a force-pump, in which the pump brake or handle is connected with the air-chamber by a separate bearing-bracket; and the air-chamber is arranged so that the pump-handle may be placed at any desired angle with the discharge-nozzle; and consists, first, in the arrangement of the valve, provided with a seat within the air-chamber and secured by a thumb-screw, so that when closed the pressure within the air-chamber will keep the valve pressed against the seat, and thus insure a tight joint; second, in the arrangement by which a cup is formed on the top of the air-chamber, partly to protect the thumb-screw by which the valve is secured, and also to readily supply water to the pump to start the suction; third, in the novel arrangement by which the air-chamber is connected with the pump-barrel so that the same can be turned on its central axis, and the brake or handle can be placed at any desired angle with the discharge-nozzle; fourth, in the novel manner in which the rocking shaft of the pump-brake is connected with a separate bearing-block, which is secured to the air-chamber, so that the rocking shaft can be arranged outside of the diameter of the air-chamber, and any de-

sired length of stroke can be given to the pump-bucket without increasing the diameter of the air-chamber.

Similar letters of reference indicate corresponding parts in the different figures of the drawings.

In the drawings, *a* represents the pump-barrel proper, within which the pump-bucket reciprocates. The upper part of this barrel is provided with a flange or other device, arranged to receive the air-chamber and make an air-tight joint, and also allow the air-chamber to be turned on its axis to any desired point, and be so secured to the barrel. *b* is the discharge-nozzle, cast in one piece with the pump-barrel *a*. *c* is the bucket, provided with a valve in the usual manner, and connected by the link-rod to the short arm of the pump lever. *d* is the connecting or link rod. *e*' is the short arm of the pump-lever, and is connected with the rocking shaft *f* by means of a screw-thread, *g*. This screw-thread is made left-handed, or so that the strain in lifting the bucket will tighten the same firmly against the shoulder provided on the rocking shaft. The rocking shaft *f* is secured in a separate piece, which is bolted onto the air-chamber so as to make an air-tight joint, and the portion of the rocking shaft extending outward to receive the pump handle or brake is surrounded by a stuffing-box or follower, *h*, by which any suitable elastic packing is compressed and a tight joint secured around the rocking shaft. This follower *h* I also prefer to provide with a left-handed screw-thread.

i is the separate supporting-piece, in which the rocking shaft *f* has its bearing, and which is connected with the air-chamber, so as to make an air-tight joint, and be readily removable. This rocking-shaft bearing is arranged to support the shaft at a point outside the diameter of the air-chamber, so that the end of the arm *E*' will be on, or nearly on, a line with the axis of the pump-barrel, so as to prevent side thrust on the bucket, and may be arranged to give any desired length of stroke to the bucket by extending the bearing for the rocking shaft farther from the central axis of the air-chamber, and lengthening the arm *E*'. *k* is the air-chamber proper, of cylin-

dricul dome-shaped form, and is provided at its upper end with the inwardly-opening valve, and a proper valve-seat, to receive the valve *l*, which is suspended by a cross-stay, and adjusted by a thumb-screw.

When the valve *l* is held to its seat, the air-chamber is air-tight, and the pump can be used as a force-pump; and any desired pressure can be obtained by exerting sufficient force on the pump-brake or handle. The pressure, instead of raising and loosening the valve, and thereby causing the same to leak, will hold the valve more firmly to the seat, and under all pressure insure a tight joint.

The air-chamber *k* is provided with the cup *m*, partly to protect the thumb-screw which secures the valve, and particularly to form a convenient receptacle through which water can be poured into the pump-barrel when the pump has lost its water, and the bucket cannot re-establish the suction. The bottom edge of the air-chamber is formed with an annular tongue, *o*, which fits into an annular groove, *p*, in the top of the barrel. This groove is to be filled with a suitable packing. The lower part of the chamber is made with a shoulder or lip, *q*; and, in combination with this, curved clamps *n n* are used, which clamps are furnished with ear-pieces corresponding with similar ear-pieces fixed on the pump-barrel. By means of screw-bolts *r* passing through these ear-pieces, the clamp-rings will operate to hold the chamber firmly upon the barrel, and cause the packing to be compressed to make a tight joint. The air-chamber being of circular section and provided with a suitable lip, *q*, on which the clamp-rings rest, the air-

chamber, and, with the same, the pump-handle, can be turned in any desired direction, so as to bring the pump-handle at any desired angle with the discharge-nozzle *b*. Three different positions of the pump-handle are indicated in Fig. 3. The pump-barrel itself may also be secured in the same manner to the base, as is shown in the drawing, and thus each may be placed in any desired position.

Having thus described our invention, we claim as new and desire to secure by Letters Patent—

1. The combination, with the pump-barrel *a*, of the air-chamber *k* and the valve *l*, arranged so as to be pressed against its seat by the pressure in the air-chamber, substantially as and for the purpose described.

2. The combination of the pump-barrel *a*, the air-chamber *k*, valve *l*, and cup *m*, substantially as and for the purpose specified.

3. The combination of the pump-barrel *a*, the air-chamber *k*, provided with the adjustable valve *l*, the pump-levers *E'* and *E*, arranged substantially as described, with the curved clamping-rings *n n*, arranged to secure the air-chamber to the pump-barrel, substantially as and for the purpose set forth.

4. The combination, with the pump-barrel *a*, the air-chamber *k*, and valve *l*, of the separate and detachable bearing-block *i*, arranged to support the rocking shaft, substantially as and for the purposes described.

WILLIAM S. BLUNT.
EDMUND BLUNT, JR.

Witnesses:

AUGUSTUS FREY,
E. B. LAZELLE.