

T. DIFFENBAUGH.  
DRAFT-PIPE FOR LOCOMOTIVES.

No. 180,853.

Patented Aug. 8, 1876.

*fig. 2.*

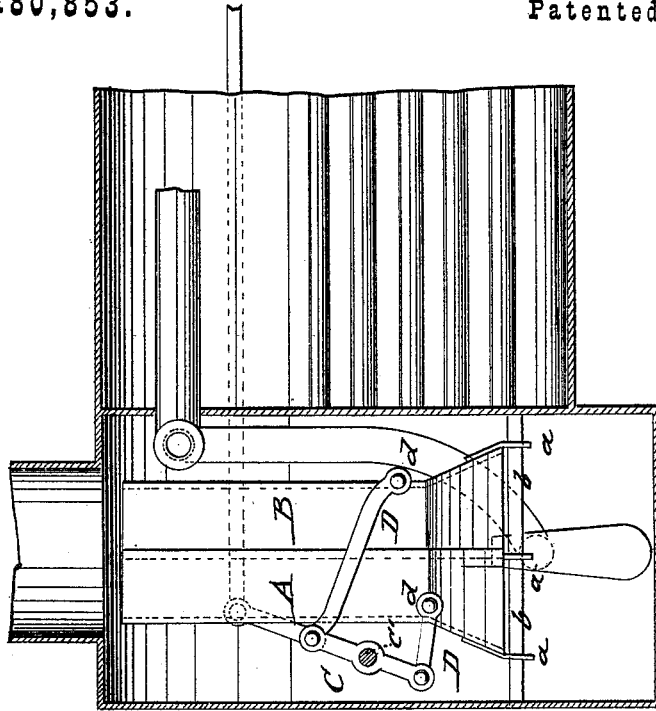

*fig. 3.*

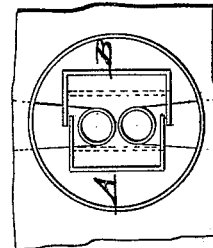

*fig. 1.*

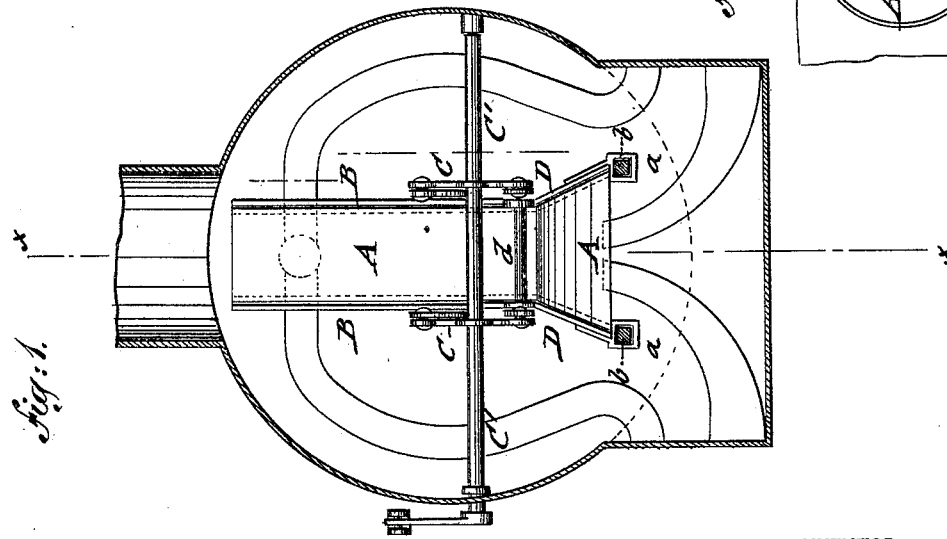

WITNESSES:

*Cros. Nava*  
*John Goethals*

INVENTOR:

*T. Diffenbaugh*  
BY *Wm. H. [Signature]*

ATTORNEYS.

# UNITED STATES PATENT OFFICE.

THOMAS DIFFENBAUGH, OF DANVILLE, ILLINOIS.

## IMPROVEMENT IN DRAFT-PIPES FOR LOCOMOTIVES.

Specification forming part of Letters Patent No. 180,853, dated August 8, 1876; application filed July 1, 1876.

*To all whom it may concern:*

Be it known that I, THOMAS DIFFENBAUGH, of Danville, in the county of Vermillion and State of Illinois, have invented a new and Improved Draft-Pipe for Locomotives, of which the following is a specification:

In the accompanying drawing, Figure 1 represents a front elevation of a locomotive with my improved draft-pipe. Fig. 2 is a vertical longitudinal section of the locomotive on line *x x*, Fig. 1, showing side view of draft-pipe; and Fig. 3 is a detail top view of the draft-pipe.

Similar letters of reference indicate corresponding parts.

My invention has reference to improvements in the draft or lifting pipe of locomotive and other high-pressure engines that exhaust into the chimney, which draft-pipe is commonly known to locomotive-engineers as a "petticoat-pipe."

The improvement consists in making the draft-pipe in sections, and adjustable by lever-connection with the cabin of the locomotive.

The common practice at present is to close up the exhaust-nozzles, which, when the engine is working at full stroke, are not large enough to allow the exhaust steam to escape freely into the smoke-stack, thereby cramping the engine, as the steam cannot be exhausted quick enough.

By making the draft-pipe variable in size, the nozzles may be made larger than at present, and the pipe then be adjusted to the volume of the exhaust steam—larger when the engine is working at full stroke and exhausting a whole cylinder of steam, and smaller when cutting off and exhausting only part of the quantity, thereby allowing the engine to work with more freedom, and maintaining a sharp draft when required.

In the drawing, A and B are the adjusta-

ble sections of my improved draft-pipe, into the lower enlarged part of which the nozzles of the exhaust-pipes discharge the steam from the cylinders. The section A is so fitted to the section B that they may readily slide along each other, their lower parts being guided by loops or eyes *a* along guide-rails *b*. A lateral crank-shaft, *C'*, is provided with fixed cranks *C*, that extend at diametrically opposite sides, and are connected by pivot links or rods *D* to pivot-pins *d* of the pipe-sections A and B, as shown in Figs. 1 and 2.

The shaft *C'* is extended to the outside of the locomotive-casing, and operated by a crank and lever-rod from the cabin of the locomotive.

When the engine is working at full stroke, the draft-pipe is made wider, as the larger amount of steam rushing through it makes the draft too strong if kept closed. While the engine is running smoothly at short stroke, the draft-pipe is set to less width, so as to sharpen up the exhaust, and produce a fierce draft through the furnace.

Having thus described my invention, I claim as new and desire to secure by Letters Patent—

As an improvement in draft or lifting pipes of locomotive and other engines, the combination of the exhaust-pipes with sliding and adjustable sections of the draft-pipe, operated by crank and lever mechanism, to set the draft-pipe to a width corresponding to the length of stroke, and to increase or diminish the draft, as the case may require, substantially in the manner and for the purpose set forth.

THOMAS DIFFENBAUGH.

Witnesses:

AUGUSTUS H. DE CLERCQ,  
S. B. FERGUSON.