

J. C. & A. P. GARRETSON.
 ROTARY WATER-ELEVATOR.

No. 180,864.

Patented Aug. 8, 1876.

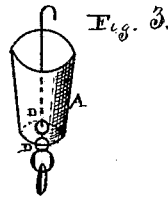
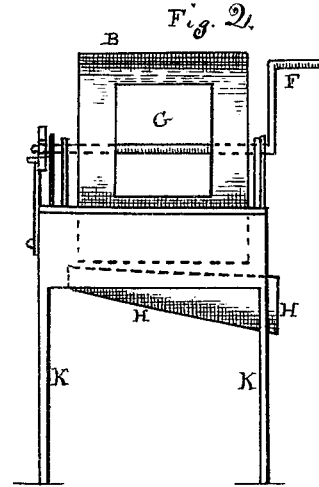
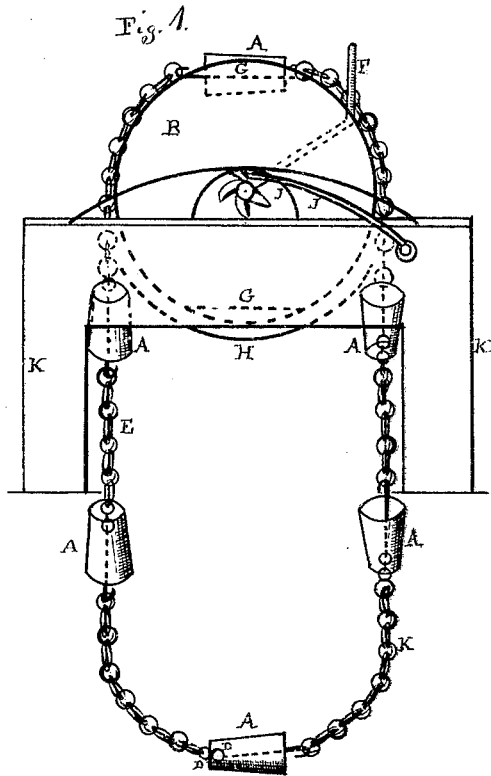

Witnesses -
Daniel Reigart
Chas. L. Coombs

J. C. Garretson
A. P. Garretson
 Inventors -
 By their Atty. *S. S. Reigart*

UNITED STATES PATENT OFFICE.

JOEL C. GARRETSON AND AMOS P. GARRETSON, OF SALEM, IOWA.

IMPROVEMENT IN ROTARY WATER-ELEVATORS.

Specification forming part of Letters Patent No. **180,864**, dated August 8, 1876; application filed January 11, 1876.

To all whom it may concern:

Be it known that we, JOEL C. GARRETSON and AMOS P. GARRETSON, of Salem, in the county of Henry and State of Iowa, have invented a new and useful machine for the purpose of elevating water, which we style the "Rotary Water-Elevator;" and we do hereby declare the following to be an exact description thereof, reference being had to the accompanying drawings, and the letters of reference marked thereon, making a part of this specification, in which—

Figure 1 represents a side elevation of the water-elevator. Fig. 2 represents an end view of the same. Fig. 3 shows the shape of the bucket and the manner by which it is attached to the chain.

The nature of our invention consists in the construction of the cylindrical drum or revolving reservoir, with its oblong apertures for receiving, holding, and emptying the buckets, revolving the endless chain, receiving the water, and again discharging it, at either side required, into the semicircular chute underneath.

The object of our invention is to hoist and elevate water from a well or river to any required height, and discharge it at any required place, and using it as a portable and movable elevator wherever desired.

To enable others skilled in the art to make and use our invention, we will proceed to describe its construction and operation, as follows:

A represents the bucket, of any required size, for the purpose of elevating and discharging water into the revolving drum or cylindrical reservoir B, and having an eye, D, on each side of the bottom, for the purpose of attaching the hooks or links of a strap or chain, E, of any required size or length, so as to connect the buckets A and form an endless chain with a series of buckets at equidistances apart. B is a hollow revolving cylinder or drum, for the purpose of operating the endless chain E, which passes over it to the well, and for the purpose of receiving and discharging the water elevated by the buckets A, and operated by means of the crank F upon the axis of the cylinder B. G G are two oblong apertures

in the opposite sides of the periphery of the hollow drum B, of sufficient size to receive the buckets A of the chain E. As the drum is revolved the buckets A of the chain E fall into the apertures G, and are there held fast until the drum is moved one-half around, when the buckets are released and returned to the well.

The apertures G hold and carry the buckets A around, while the buckets empty their water into the drum B through the apertures in a continuous and rotary motion of the drum B and endless chain E.

The water received by the drum B through the upper or top aperture G is discharged through the aperture G at the lower part of the drum B, falling in a stream upon the semicircular incline chute H, that surrounds the lower half of the drum B.

The semicircular incline chute H encircles the lower side of the drum B between the sides of the endless chain E, with its concave surface uppermost, for the purpose of receiving the water as it falls from the drum B, and conveying it to a tank or reservoir beneath.

J is a common dog and ratchet upon the axis of the drum B, for the purpose of locking and preventing the reverse action of the drum B and endless chain E, with loaded buckets A upon the ascending side of the endless chain. K is an ordinary upright frame that supports the drum B.

What we claim as our invention, and desire to secure by Letters Patent, is—

1. The cylindrical drum A, with its apertures B B, for receiving and emptying the buckets C C, revolving the endless chain D, and receiving the water and discharging it upon the chute E below, when constructed and operating as herein described, for the purposes set forth.

2. The bucket C, having its bottom secured between the eyes D D of the endless chain, as constructed and operating as herein set forth.

JOEL C. GARRETSON.
AMOS P. GARRETSON.

Witnesses:

J. FRANKLIN REIGART,
DANIEL REIGART.