

A. H. LEACH, dec'd.
 D. L. DEMOREST, Adm'r.
 MORTISE-LATCH.

No. 180,894.

Patented Aug. 8, 1876.

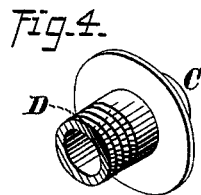
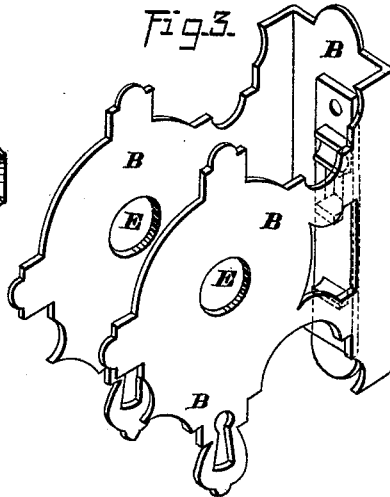
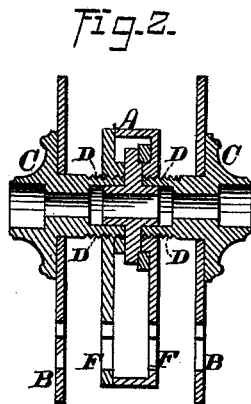
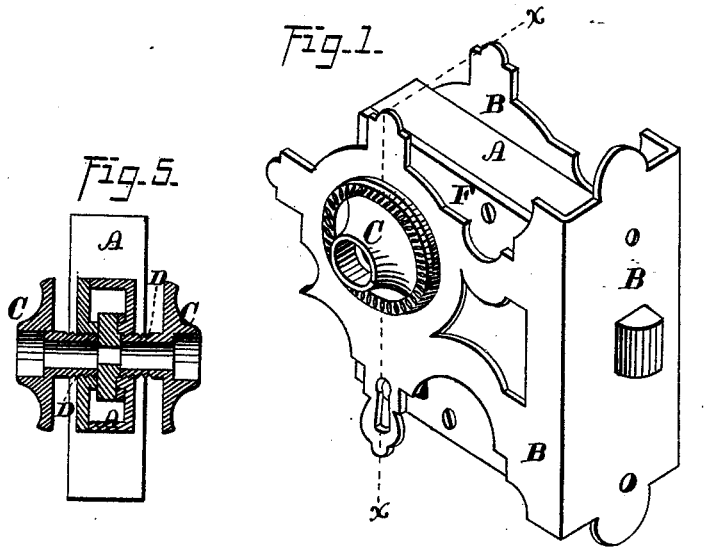

WITNESSES-
Jack Hutchinson
John R. Young

INVENTOR-
A. H. Leach, dec'd
D. L. Demorest, Adm'r.
by Prindle and Co, his Attys

UNITED STATES PATENT OFFICE.

ALBERT H. LEACH, OF CHICAGO, ILLINOIS, (DAVID L. DEMOREST,
ADMINISTRATOR.)

IMPROVEMENT IN MORTISE-LATCHES.

Specification forming part of Letters Patent No. **180,894**, dated August 8, 1876; application filed
July 22, 1870.

To all whom it may concern:

Be it known that ALBERT H. LEACH, deceased, late of Chicago, Cook county, State of Illinois, did invent certain new and useful Improvements in Locks and Latches, of which the following is a full, clear, and exact description, reference being had to the accompanying drawings, making a part of this specification, in which—

Figure 1 is a perspective view of the improved metallic case or shield and collars or flanges, as applied to an ordinary mortise lock or latch designed for use in doors that are constructed of wood. Fig. 2 is a vertical cross-section of the same on line *x x* of Fig. 1. Fig. 3 is a perspective view of the metallic case or shield detached from a mortise-lock. Fig. 4 is a perspective view of one of the collars or flanges, showing a projecting hub with a threaded screw cut upon the end of said hub, and Fig. 5 is a vertical cross-section of a mortise lock or latch, with the collars or flanges in position, but without the metallic case or shield.

Letters of like name and kind refer to like parts in each of the figures.

The object of this invention is to increase the efficiency of mortise locks and latches used in doors that are constructed of wood; and to this end it consists, principally, in combining with a mortise lock or latch a metallic case or shield, that is securely fastened to and upon that end of a mortise lock or latch through which the sliding bolt or bolts project, and which is caused to pass around and clasp each side of a door, covering that part of said door that is mortised to receive said lock or latch, in the manner and for the purpose substantially as is hereinafter shown and described. It consists, further, in combining, with a mortise lock or latch and a metallic case or shield, designed for doors that are constructed of wood, two collars or flanges, each having a projecting hub upon its inner side, the ends of which hubs are provided with screw-threads that extend a short distance outward, which threads correspond with and match other threads that are cut in the side plates of a mortise lock or latch, so that when said collars or flanges are firmly screwed into said side plates—the projecting

hubs having been passed through holes in the side plates of the case or shield, provided for that purpose—they will cause the latter to be firmly clasped to the door, in the manner and for the purpose substantially as is hereinafter shown and described.

In the annexed drawings, A represents an ordinary mortise lock or latch, to which is attached a metallic case or shield, B, the sides of which may be cut as shown in the drawing, or they may be made plain, if preferred. The sides of said metallic case or shield B are designed to be of sufficient area to fully cover that portion of a wooden door that is mortised to receive the lock or latch. Said case or shield B is secured upon and fastened to the forward edge of a mortise lock or latch, A, through which the bolt or bolts project and operate, by means of two or more counter-sink-headed screws. Two collars or flanges, C and C, are provided for the double purpose of furnishing bearings for the shaft of the knob-handles, and for clamping the sides of the case or shield firmly to the door. Said collars or flanges are each provided with a hub or projection upon their inner sides, and upon the end of said hub a screw-thread, D, is cut, which extends a short distance outward toward the flange itself, and said screw-thread matches with, and fits into, a corresponding thread, that is cut in each of the side plates or caps of the lock or latch A. A hole, E, corresponding in size with the diameter of the hubs of the collars or flanges C and C, is formed in each of the side plates of the case or shield B, and, as will be observed, when the collars are screwed firmly into the side plates of the lock or latch A, the hubs of said collars are caused to pass through the holes E and E of the side plates of the case or shield B, so that the latter will by this means be firmly clasped to the side of the door.

It will be observed that by this arrangement the case or shield B and the collars or flanges C and C may be used separately or in combination with each other.

The advantages possessed by this improvement are: the door is greatly strengthened in consequence of being clasped by the metallic case or shield, and the collars, by being

firmly screwed into the side plates of the lock, and supported by the case or shield, furnish a firm unyielding support for the knobs, rendering the lock and its attachments more durable and less likely to get loose and out of order than is the case as they are usually constructed and fastened.

Having thus fully set forth the nature and merits of this invention, what is claimed as new is—

1. In combination with a mortise lock or latch, A, that is designed for use in doors that are constructed of wood, a metallic case or shield, B, fastened to, and secured upon, that end of a mortise lock or latch through which the sliding bolt or bolts project, and which is caused to pass around in such a manner as to clasp each side of said door, and cover that part or portion that is mortised to receive said lock, in the manner and for the purpose substantially as shown and described.

2. In combination with a mortise lock or latch, A, and metallic case or shield B, designed for doors that are constructed of wood, two collars or flanges, C and C, each having a projecting hub upon its inner side, the ends of which hubs are provided with screw-threads that extend a short distance outward toward the flange itself, which threads correspond with and match other threads that are provided in the side plates F F of a mortise lock or latch, so that when said collars or flanges C and C are firmly screwed into said side plates F and F they will cause the side plates of the case or shield B to be tightly clasped to the door, in the manner and for the purpose substantially as shown and described.

ALBERT H. LEACH.

Witnesses:

I. B. APPLETON,
R. ROGERSON.