

L. PRAHAR.

FEED-DEVICE FOR PUNCHING-MACHINES.

No. 180,924.

Patented Aug. 8, 1876.

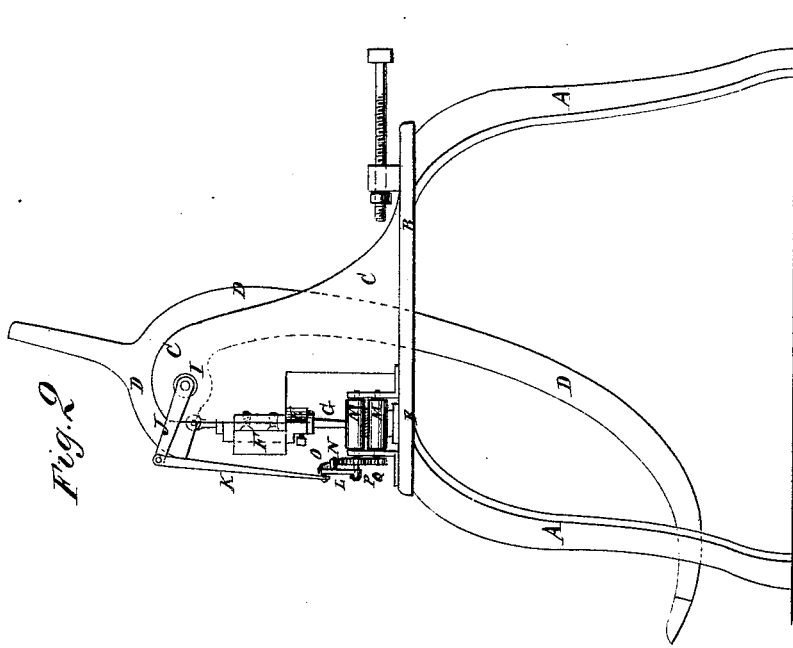

Fig. 2

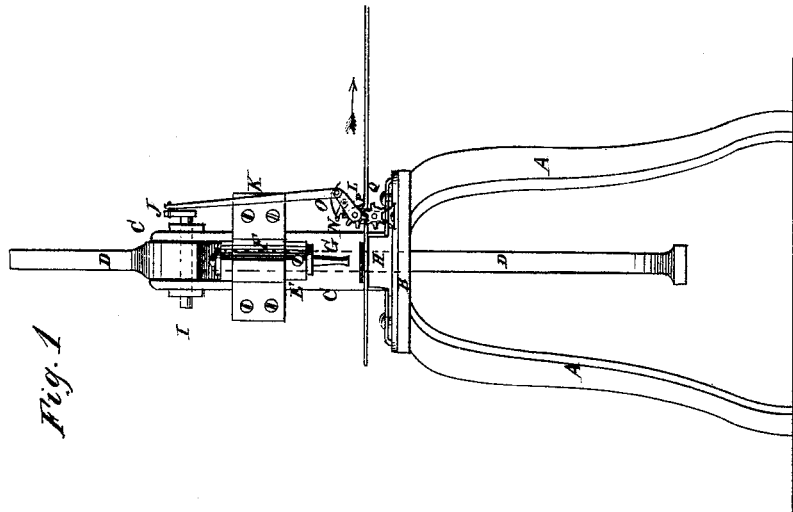

Fig. 1

WITNESSES:

John Goethals
Alex. F. Roberts

INVENTOR:

L. Prakar

BY

Munnell

ATTORNEYS.

UNITED STATES PATENT OFFICE

LOUIS PRAHAR, OF NEW YORK, N. Y.

IMPROVEMENT IN FEED DEVICES FOR PUNCHING-MACHINES.

Specification forming part of Letters Patent No. **180,924**, dated August 8, 1876; application filed July 11, 1876.

To all whom it may concern:

Be it known that I, LOUIS PRAHAR, of the city, county, and State of New York, have invented a new and Improved Self-Feed for Foot-Motion Presses, of which the following is a specification:

Figure 1 is a front view of a foot-press to which my improvement has been applied. Fig. 2 is a side view of the same.

The object of this invention is to furnish an improved automatic feed attachment for foot-presses for punching and cutting sheet metal, which shall be so constructed as to feed the material forward to the cutting-tool as it is required, and which shall be simple in construction, convenient in use, and readily applied to the press.

The invention will first be described in connection with the drawing, and then pointed out in the claim.

Similar letters of reference indicate corresponding parts.

A are the legs. B is the bed-plate. C is the pedestal. D is the pendulum. E is the tool-holder. F is the tool-holder guide. G is the tool, and H is the die, about the construction of all of which parts there is nothing new. I is the pivot, which is attached to the pendulum D, and works in bearings in the pedestal C. To the pivot I is attached an arm, J, to the outer end of which is pivoted a connecting-rod, K, the lower end of which is pivoted to a small crank, L. The crank L is pivoted to the journal of the upper feed-roller M, and

to said crank is pivoted a pawl, N, which is held down by a spring, O, and engages with the teeth of a gear-wheel, P, attached to the upper feed-roller M. The teeth of the gear-wheel P mesh into the teeth of a gear-wheel, Q, attached to the lower end of the feed-roller M, so that the said rollers M may move together, and in opposite directions, to carry forward the material to be operated upon. The feed-rollers M are pivoted to a small frame attached to the bed-plate B.

With this construction the movement of the pendulum D will operate the feed-rollers M, to carry the material forward to the cutting-tool G, the rapidity of the feed being regulated by the size of the gear-wheels P Q.

The arm J may be connected with the pivot of the pendulum, as herein shown and described, with the pendulum itself, or with the tool-holder, as may be most convenient.

Having thus described my invention, I claim as new and desire to secure by Letters Patent—

The combination of pivot I, having pendulum D and arm J, with the pivoted rod K, the crank L, having spring-pawl N, and the gear-wheels P, as shown and described, to form an improved mechanism for operating the feed-rolls of a punching-machine.

LOUIS PRAHAR.

Witnesses:

JAMES T. GRAHAM,
T. B. MOSHER.