

R. J. SHEEHY.

ELECTRIC REGISTERING TURNSTILE.

No. 180,944.

Patented Aug. 8, 1876.

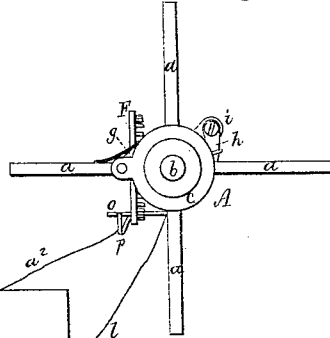

Fig. 1.

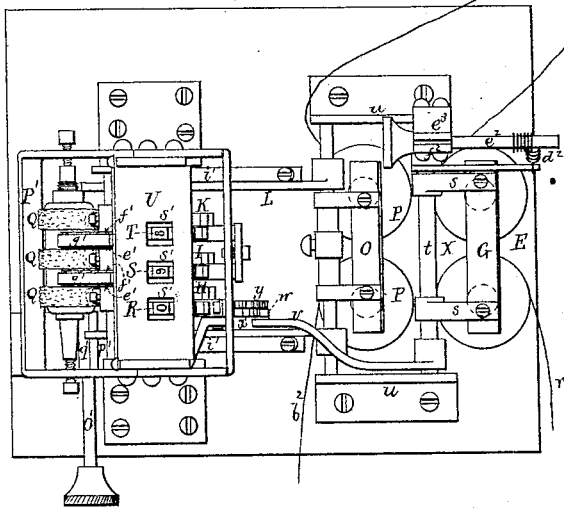
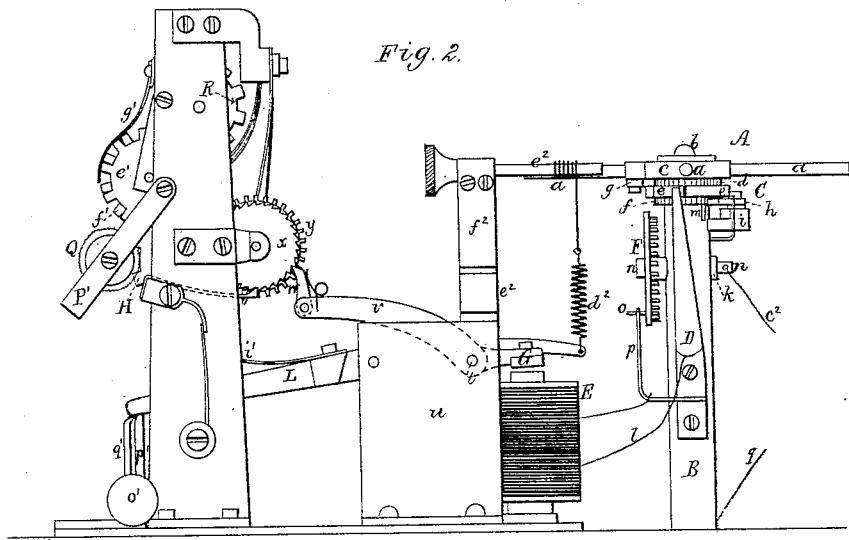

Fig. 2.



Witnesses  
S. W. Piper  
L. H. Miller

Robert J. Sheehy  
by his attorney  
R. W. Eddy

R. J. SHEEHY.

ELECTRIC REGISTERING TURNSTILE.

No. 180,944.

Patented Aug. 8, 1876.

Fig. 4.

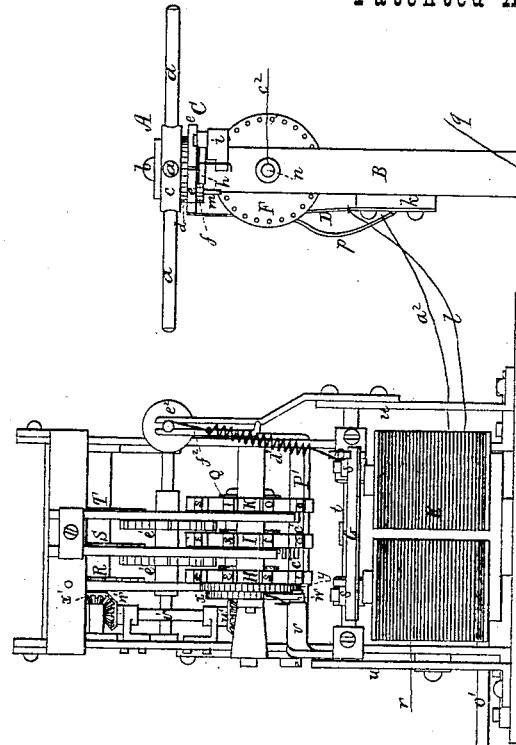
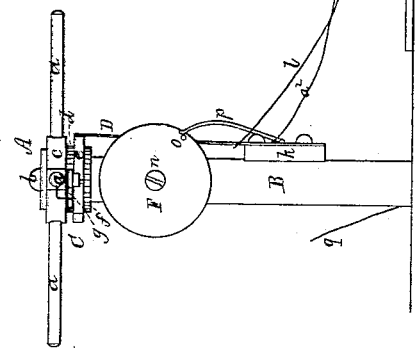
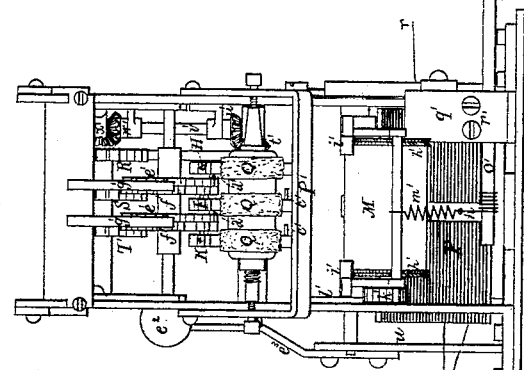

Fig. 3.



Witnesses  
*S. W. Piper*  
*L. W. Müller*

*Robert J. Sheehy*  
 by his attorney,  
*R. H. Edsall*



# UNITED STATES PATENT OFFICE.

ROBERT J. SHEEHY, OF BOSTON, MASSACHUSETTS.

## IMPROVEMENT IN ELECTRIC REGISTERING-TURNSTILES.

Specification forming part of Letters Patent No. **180,944**, dated August 8, 1876; application filed May 22, 1876.

*To all whom it may concern:*

Be it known that I, ROBERT J. SHEEHY, of Boston, in the county of Suffolk and State of Massachusetts, have invented a new and useful apparatus for indicating and registering the number of persons who from time to time may pass into an inclosure; and I do hereby declare the same to be fully described in the following specification, and represented in the accompanying drawings, of which—

Figure 1 is a top view, Fig. 2 a side elevation, Fig. 3 a rear-end elevation, Fig. 4 a front-end elevation, Fig. 5 a longitudinal section, and Fig. 6 a transverse section, of the said apparatus.

The mechanism hereinafter described not only will indicate to the eye, but will print or register on a sheet or strip of paper the number of persons who may pass a given point during any period of time. It is useful for race-course stands, theaters, or exhibitions of various kinds.

In the said drawings, A denotes a turnstile, pivoted to a post, B, and provided with four arms, *a a a a*, arranged at right angles to each other. On the pivot *b* of the turnstile, and between the hub *c* of the latter and the top of the post, is a triplex ratchet-wheel, C, or one having three ranges, *d e f*, of teeth, arranged as shown, the intermediate range *e* having four teeth at equal distances asunder. An impelling-pawl, *g*, pivoted to the hub of the turnstile, engages with the range *d*. A retaining-pawl, *h*, pivoted to the post or projection *i*, therefrom engages with the range *f*, in order therewith to prevent the triplex ratchet-wheel C from being revolved backward. Projecting upward from the post, and insulated from it by a piece of hard rubber, K, is a metallic spring, D, to operate with the middle range, *e*, of teeth of the ratchet-wheel C. While either tooth of the range *e* may be in contact with the spring the circuit of the electro-magnet E will be closed, and will be open when the spring is not in contact with such tooth. A circuit-wire, *l*, leads from the spring to the said magnet. From the ratchet-wheel C a tooth, *m*, extends downward to operate a wheel, F, having a circular range of twenty-five teeth projecting from its inner side, the said wheel

being arranged, as shown, with the post, and having its pivot *n* electrically insulated from such post. There projects from the opposite side of the wheel F a stud, *o*, which, at each entire revolution of the wheel, will be carried into contact with the free end of another metallic spring, *p*, projecting from the spring D. A circuit-wire, *q*, leading from the posts is to be supposed to pass to one pole of a galvanic battery, another wire, *r*, leading from one of the coils of the magnet E being supposed to be in communication with the battery at its opposite pole. During each revolution of the turnstile the wheel F will be turned the twenty-fifth part of a revolution, and the armature G of the magnet E will be attracted toward such magnet four times. This armature is carried by a lever, X, consisting in part of two arms, *s s*, projecting from a horizontal shaft, *t*, supported in standards *u u*. From the said shaft a long arm, *v*, is projected, as shown, and carries an impelling-pawl, *w*, to actuate a ratchet-wheel, *x*, provided with thirty teeth, and fixed to the side of a gear, *y*, having a like number of teeth. The gear *y* engages with a pinion, *z*, fixed to the side of a type-wheel, H, having types for printing the units or number characters 0 1 2 3 4 5 6 7 8 9. Other type-wheels, I K, arranged as shown, and similarly made, are placed on the same shaft *b*<sup>1</sup> with the wheel H. From one side of each of the wheels I K there projects a circular range, *c*<sup>1</sup>, of ten studs or teeth, there being one stud or tooth, *d*<sup>1</sup>, extended from the other side of said wheel I, and also from the wheel H. The tooth *d*<sup>1</sup> of the wheel H operates with the gear *e*<sup>1</sup> of a pair of gears, *e*<sup>1</sup> *f*<sup>1</sup>. The other of such gears (viz., *f*<sup>1</sup>) engages with the range *c*<sup>1</sup> of the wheel I, whose tooth *d*<sup>1</sup> engages with one gear, *e*<sup>1</sup>, of another pair of gears, *e*<sup>1</sup> *f*<sup>1</sup>, whose gear *f*<sup>1</sup> engages with the range *c*<sup>1</sup> of the gear K. Each pair of gears *e*<sup>1</sup> *f*<sup>1</sup> has a spring, *g*<sup>1</sup>, bearing against its periphery to hold it from accidentally revolving.

From the above, it will be seen that during each descent of the armature G the type-wheel H will be turned one-tenth of a revolution. Also, that during each entire revolution of such wheel the next type-wheel I will be revolved a tenth of a revolution. Also,

that during each entire revolution of the wheel I the wheel K will be revolved the tenth of a revolution.

Under the series of type-wheels H I K is a lever, L, carrying on its longer arm a roller, M, upon which a band, N, of paper rests. The other arm of the lever carries an armature, O, to operate with another electro-magnet, P, all being as shown. The type-wheels have arranged with them, as represented, a set of inking-wheels, Q, whose arbor is within and pivoted to a swing-frame, P'. The strip of paper is pressed upon toothed wheels  $h' h'$  at the ends of the roller M, by springs  $i' i'$ , and the said roller is provided with a ratchet feed-wheel,  $k'$ , which, every time the roller may be thrown up, will be met by a pawl,  $l'$ , and partially revolved, such being to revolve the roller M and its wheels  $h' h'$ , in order to feed along the band or strip of paper. There is fixed to the longer arm of the lever L one end of a helical spring,  $m'$ , whose other end has a cord,  $n'$ , extended from it, fastened to and wound around a windlass-pin,  $o'$ , pivoted between a standard,  $p'$ , and a plate,  $q'$ , arranged as shown. The said plate  $q'$  is held to the standard by screws  $r'$ , which serve to clamp the plate against the pin, so as to cause the latter to revolve with more or less friction, as occasion may require.

Above the type-wheels there is arranged a set of indicators or gear-wheels, R S T, like such type-wheels, and numbered as they are on their peripheries. Over the set of indicator-wheels is a plate, U, having an opening,  $s'$ , through it, directly over each of the said wheels. The wheels R S T are to revolve on one shaft, independently of each other, the two wheels S T engaging with the gears  $f^1 f^1$ . On the side of the type-wheel H is a bevel-gear,  $t'$ , which engages with a like gear,  $w'$ , fixed on a vertical shaft,  $v'$ , which also carries another bevel-gear,  $w'$ , that engages with a like gear,  $x'$ , fixed on the side of the indicator-wheel R. The wheels R S T are to, and will, revolve synchronously with the type-wheels H I K, from which it will be seen that the numbers printed at any time by the latter, or the number of quarter revolutions of the turnstile at any time, may be ascertained by looking through the openings of the plate U upon the indicator-wheels.

The tooth  $m$ , toothed wheel F, and the spring  $p$  are to cause the printing of the paper to take place once in every twenty-five revolutions, in order to register the passage of every hundred persons into the inclosure.

A separate circuit and battery are to be used for working the magnet P, the spring  $p$  and the arbor of the wheel F being in the said circuit, whose wires are shown at  $a^2$ ,  $b^2$ , and  $c^2$ . The armature-lever X has applied to it a lifter-spring,  $d^2$ , having a take-up windlass or rod,  $e^2$ , the latter being supported by a standard,  $e^3$ , and friction-clamp  $f^2$ , all being arranged as represented.

In the use of my apparatus for counting or determining or registering the number of persons who, during any period, may have passed into or out of an inclosure, the turnstile should be so arranged at or in a passage that each person, in passing either into or out of such passage, shall revolve the turnstile a quarter of a revolution thereof.

I claim—

1. The combination of the turnstile A, ratchet-wheel C, impelling and retaining pawls  $g h$ , and spring D, with a registering mechanism, substantially as described, consisting essentially of the electro-magnet E, its armature G, armature-lever X, impelling-pawl  $w$ , ratchet-wheel  $x$ , gears  $y z$ , and the series of type-wheels H I K, and their operative gears  $e^1 f^1$  and pins  $d^1 d^1$ , the lever L, roller M, armature O, and electro-magnet P, all arranged and applied as set forth.

2. The combination of the tooth  $m$ , toothed wheel F, stud  $o$ , and spring  $p$ , with the turnstile A, ratchet-wheel C, impelling and retaining pawls  $g h$ , spring D, and the registering mechanism, substantially as described.

3. The combination of the set of indicators R S T, provided with operative mechanism, as described, with the registering mechanism, essentially as set forth, and with the turnstile A, ratchet-wheel C, impelling and retaining pawls  $g h$ , and spring D, all being applied essentially as specified.

R. J. SHEEHY.

Witnesses:

R. H. EDDY,  
J. R. SNOW.