

A. J. STEVENS.  
FLUE AND TUBULAR BOILER.

No. 180,956.

Patented Aug. 8, 1876.

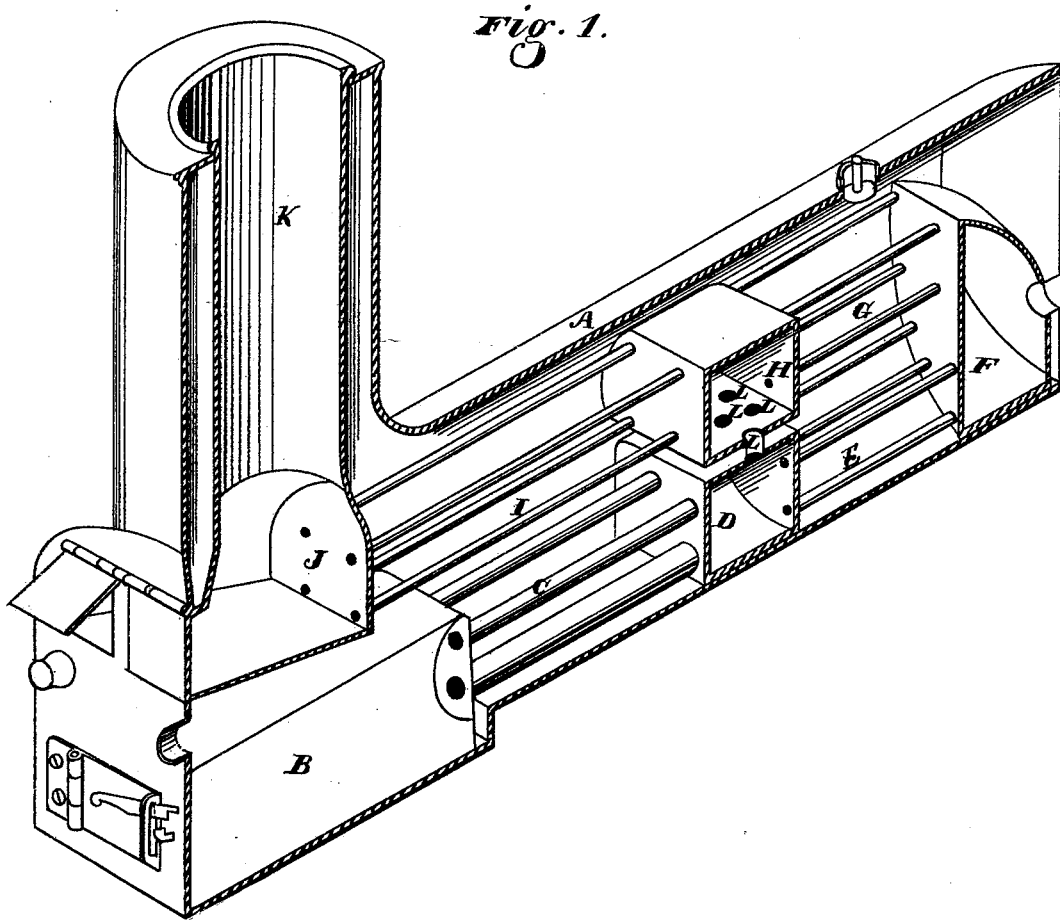

Witnesses  
*Geo. H. Strong*  
*Jos. H. Bond*

Inventor  
*Andrew J. Stevens*  
*by Dewey & Co.*  
*Attys*

# UNITED STATES PATENT OFFICE.

ANDREW JACKSON STEVENS, OF SACRAMENTO, CALIFORNIA.

## IMPROVEMENT IN FLUE AND TUBULAR BOILERS.

Specification forming part of Letters Patent No. **180,956**, dated August 8, 1876; application filed June 21, 1876.

*To all whom it may concern:*

Be it known that I, ANDREW J. STEVENS, of the city and county of Sacramento, State of California, have invented certain new and useful Improvements in Boilers; and I do hereby declare the following description and accompanying drawings are sufficient to enable any person skilled in the art or science to which it most nearly appertains, to make and use my said invention without further invention or experiment.

My invention relates to certain improvements in the construction of boilers of the return tubular class; and it consists in the employment of two chambers, situated one above the other, and at some point between the ends of the boiler, so that four flue-sheets are provided for securing the flues and tubes, which are thus made correspondingly shorter, while the elasticity of these sheets allows for the difference of expansion and contraction between the tubes and the shell of the boiler much better than when the flues extend the full length, and thus reduces the danger of breaking the flues off at the point where they are secured to the sheets. The chambers give more room and time for the combustion of gases and a larger amount of heating-surface, while, by connecting the upper and lower chambers by short tubes, flame is allowed to pass from the lower to the upper one, so as to ignite and keep up the combustion of the gases, which have passed through to the back-connection and returned to this point.

Referring to the accompanying drawing for a more complete explanation of my invention, Figure 1 is a perspective view of my boiler.

A is the shell of my boiler, which I have shown constructed of the pattern known as the marine boiler, and B is the fire-box. From the fire-box the flues C extend to near the center of the boiler, where they enter one side of a chamber, D. This chamber may be made of any suitable shape, and stayed to resist the pressure of steam. Tubes E extend from the chamber D to the chamber F, known as the back connection, and from the upper part of this chamber other tubes, G, return above the tubes E and enter a chamber, H, which is situated just above the chamber D. Still another set of tubes, I, connect the chamber

H with the uptake J, from which the remaining products of combustion and the smoke are carried off by the stack or chimney K. Short tubes, L, connect the chambers D and H, to allow flame and heat from the lower chamber to pass into the upper one.

The operation will now be as follows: Heat, flame, and unconsumed gases pass from the fire-box through the flues C, and enter the chamber D, where the gases have time and space for a more complete combustion before entering the tubes E, through which they pass, to the back-connection F, thence, returning through the tubes G, to the upper combustion-chamber H. The principal part of the products of combustion will take this course, and, parting with their heat as they pass through the tubes, will become considerably cooled when they reach the chamber H. The short tubes L, which connect the chambers D and H, however, allow a portion of the more intense heat and flame from the chamber D to pass directly into the chamber H, thus increasing the temperature of the remaining unburned gases to such a point that they will again become ignited and burned in the upper chamber H before entering the tubes I, and passing on to the up-take and chimney.

It will be readily seen that in addition to a more perfect combustion, I also obtain a greater amount of heating-surface than would be the case if the chambers were dispensed with.

A further advantage is found in the fact that I am enabled to make my flues and tubes in four sets, less than half the usual length, and with a correspondingly less contraction and expansion by cooling and heating. The walls of the chambers D and H, receiving the ends of the tubes in the same manner as the flue-sheets, provide an elastic support at each end of each set of flues, which will easily compensate for the differences of expansion and contraction, which take place between the tubes and the shell of the boiler; and I am thus enabled to entirely prevent the breaking of the tubes at the neck or point where they are secured to the sheets—a common difficulty where flues extend the full length of the boiler.

Having thus described my invention, what I claim is—

The chambers D and H, situated one above the other at a point between the ends of the boiler, and united by the tubes L, said chambers serving to increase the combustion and heating-surface, and providing elastic supports for the ends of the tubes, in combina-

tion with the boiler A and tubes C E G I, substantially as and for the purposes herein described.

ANDREW JACKSON STEVENS.

Witnesses:

JOHN RAFFERTY,  
GEO. H. STRONG.