

W. BELLIS.
OSCILLATING VALVES.

No. 181,131.

Patented Aug. 15, 1876.

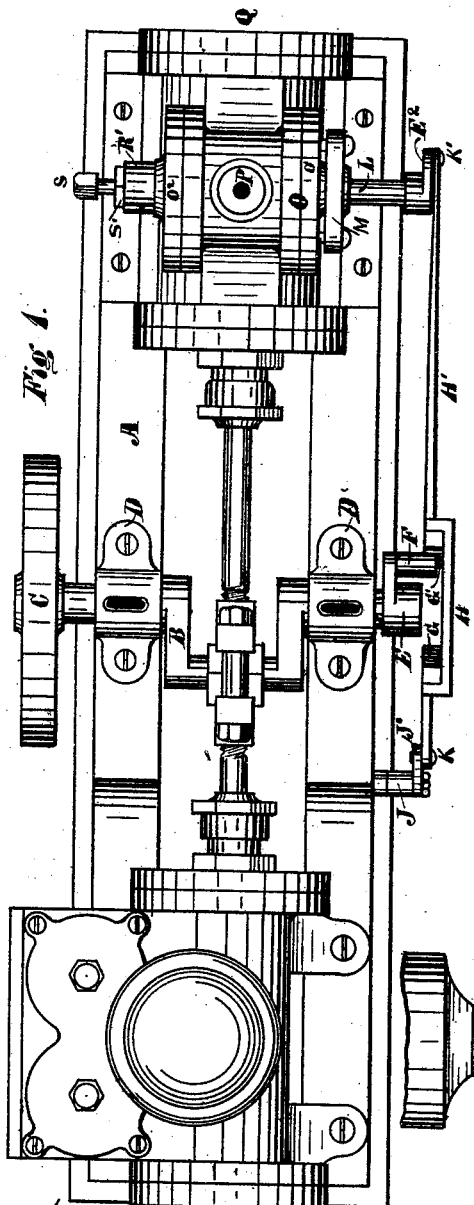

Fig. 1.

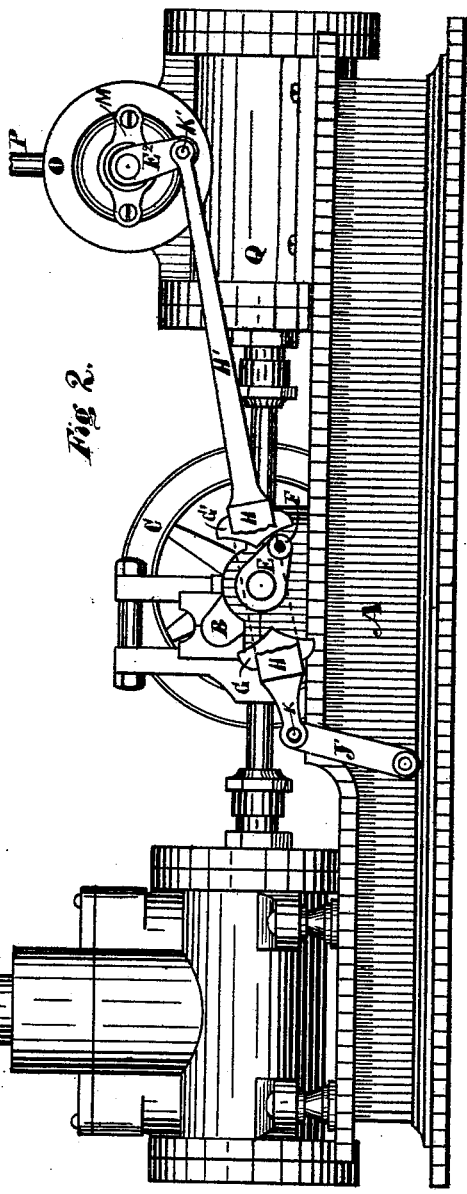

Fig. 2.

Witnesses:
E. O. Whitney
W. J. Austin

Inventor:
William Bellis
Per C. W. Smith his atty.

W. BELLIS.
OSCILLATING VALVES.

No. 181,131.

Patented Aug. 15, 1876.

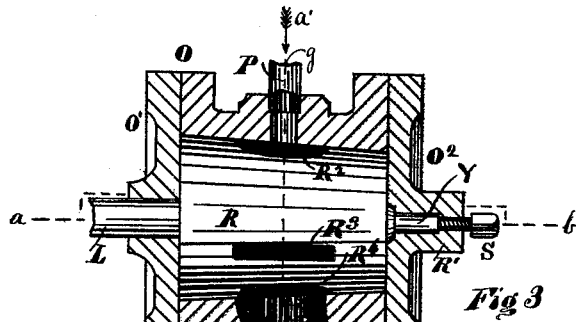

Fig 3

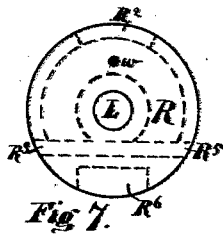

Fig 7.

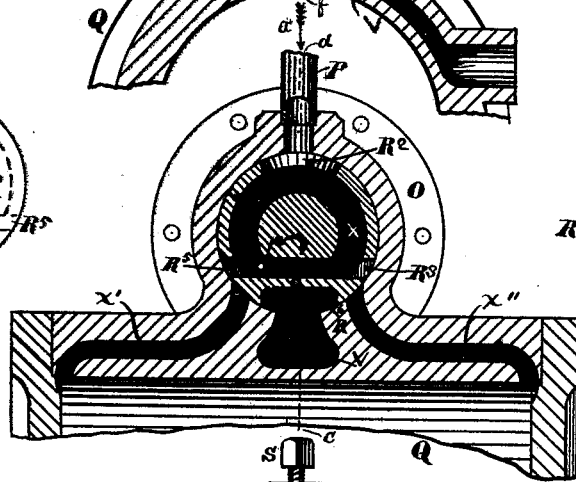

Fig 4.

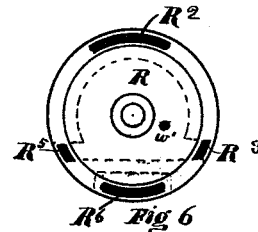

Fig 6

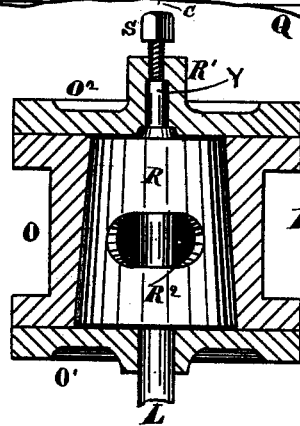

Fig 5.

Witnesses;
 E. C. Whitney
 W. J. Anson

Inventor
 William Bellis.
 Ben C. Merritt
 his Atty.

UNITED STATES PATENT OFFICE.

WILLIAM BELLIS, OF INDIANAPOLIS, INDIANA.

IMPROVEMENT IN OSCILLATING VALVES.

Specification forming part of Letters Patent No. **181,131**, dated August 15, 1876; application filed April 24, 1876.

To all whom it may concern:

Be it known that I, WILLIAM BELLIS, of Indianapolis, county of Marion, State of Indiana, have invented a new and useful Improvement in Valves for Steam-Engines, Pumps, &c., of which the following is a description, reference being had to the accompanying drawings.

My invention relates to rotary or oscillating valves, as applied to steam-engines, pumps, &c.; and it consists of a conical valve, formed with a slight taper, and fitted nicely in a tapered shell. The valve is constructed with an entry-port for live steam, which makes connection with side ports on opposite sides of the valve, which, in turn, makes connection with the steam-ports of the main cylinder of the pump or engine. The valve may have any required lap or lead. Between the side steam-ports of the valve is arranged the exhaust-port, which communicates with the exhaust-chamber of the main cylinder. The ports are arranged to operate with an oscillating or partially-rotary motion to perform the same results as a common slide-valve. At each end of the valve are arranged small ports, which will allow sufficient steam to pass to the ends of the valve to balance it.

The valve may be operated by means of cams and levers, as shown in the drawings, when applied to pumps. This arrangement reverses the valve quickly at each end of the stroke; but when applied to steam-engines I prefer an eccentric, which will give the balanced oscillating valve the easy continuous motion that is applied to the ordinary slide-valve.

In the drawings, Figure 1, Sheet 1, represents a plan view of my improved valve, as applied to a steam-crank pump. Fig. 2, Sheet 1, represents a side elevation of the same, with a portion of the cam-rod broken away. Fig. 3, Sheet 2, represents a central cross-section of the main steam-cylinder and a corresponding longitudinal section of the valve-case, with the oscillating valve in position, taken through the line *cd* of Fig. 4. Fig. 4, Sheet 2, represents a longitudinal section of the main steam-cylinder, with a corresponding cross-section of the valve-case and oscillating

valve, showing the interior arrangement of the ports in the valve and ports in the main cylinder, taken through the lines *fg* of Fig. 3. Fig. 5, Sheet 2, represents a longitudinal section of the valve-case, with the valve therein, taken through the line *ab* of Fig. 3. Fig. 6 represents an end view of the oscillating valve, at the small end, and shows the arrangement of steam and exhaust ports, and the small ports at the extreme end that are used to balance the valve endwise at that end, and also to lubricate it. Fig. 7 represents an end view of the oscillating valve at the large end, and shows the arrangement of ports inside by dotted lines, and also shows the small steam-ports at the end that are used to balance the valve endwise at that end, and also to lubricate it.

In the drawings, I have represented my improved valve on a steam-crank fly-wheel pump, of which A represents the bed, on which is mounted the steam-cylinder Q and water-cylinder, with the main crank-shaft B supported in the boxes D D' in the usual manner for such class of pumps. On the main steam-cylinder Q of the pump or engine is located the oscillating valve-case O, which is bored out with a slight taper from one end to the other, as shown in Figs. 3 and 5 of Sheet 2. This valve-case is provided with steam-ports X' X'' and exhaust-port V in the same manner as an ordinary slide-valve, except that instead of the ports being on a plan, as in the ordinary slide-valve, they are arranged with the exhaust-port V at the lower edge of the cylindrical valve-case, and the live-steam ports X' X'' are further up on the cylindrical case, as shown in Fig. 4, Sheet 2. The valve-case O is further provided with an inlet-port for live steam, in which is secured the steam-pipe P, as shown in the drawing. This port may be located at any part desired of the valve-case O; but I prefer it at the top opposite the exhaust-port V. At each end of the cylindrical valve-case O are secured the heads O¹ O². The head O¹ is provided with a stuffing box and gland, M, to make a tight joint on the valve-stem L, and the other head O² is provided with a hole to receive the small end Y of the valve-stem L, and also is provided with

a set-screw, S, to adjust the valve R, as shown in Figs. 3 and 5 of Sheet 2, and in Fig. 1 of Sheet 1.

The valve R is a partially-hollow conical frustum, made of any metal, the ends of which are closed, and the valve is turned with a taper, to fit nicely in the case, and is provided with a port, R², above, of sufficient width to allow all of the steam to enter from the steam-pipe P of the case O into the hollow part X of the valve R at any inclination the valve may be placed at, and the valve R is also provided with two ports, R³ R⁵, connected with the hollow part X of the valve that is provided with the port R². These ports R³ R⁵ are placed at the proper distances for the steam to pass through to either of the main steam-ports X' or X'' of the main steam-cylinder Q, as shown, and the valve R is also provided with a hollow recess, R⁶, on the outer surface of the valve, to allow the exhaust steam to pass.

By this arrangement of an oscillating valve and case the steam passes direct to the interior of the valve itself, through the port R², and has no pressure in any one direction more than in another. It is, therefore, perfectly balanced. The valve is supported on the valve-stem L Y, in the manner shown, and the small end Y of the stem L operates in the socket formed in the central part of the head O², and impinges against a set-screw, S, which is in the head O², and is so arranged as to adjust the valve to a nicety. At the large end of the valve R I have arranged a small hole or port, w, for the purpose of lubricating and to hold

the valve close up to its working position by means of the steam that passes from the inside of the valve to the outside into the space between the end of the valve and the head of the valve-case O, and in order to partially counterbalance this pressure, and also to lubricate the valve more perfectly, I bore a small hole, w', through the small end of the valve, which opens into the live-steam recess of the valve above the exhaust-chamber. There is sufficient difference in the area of the two ends of the valve, by means of the taper thereto, to allow the live steam at the large end to predominate over live steam at the small end, and thus hold the valve R up against the set-screw S.

I do not here claim mechanism shown other than the valve, as it will form the subject of another application; but

What I claim as new, and wish to secure by Letters Patent, is—

A hollow tapering valve, having lateral outlet and exit ports, closed at the ends, and provided in said closed ends with openings w w', whereby steam is permitted to escape from within the valve to the spaces between the closed ends and the heads of the chest, to balance the valve laterally, as set forth.

In testimony whereof I have signed my name to this specification in the presence of two subscribing witnesses.

WILLIAM BELLIS.

Witnesses:

HIRAM B. BRUBAKER,
E. O. FRINK.