

T. M. BRINTNALL.

RECLINING CHAIR.

No. 181,137.

Patented Aug. 15, 1876.

Fig. 1.

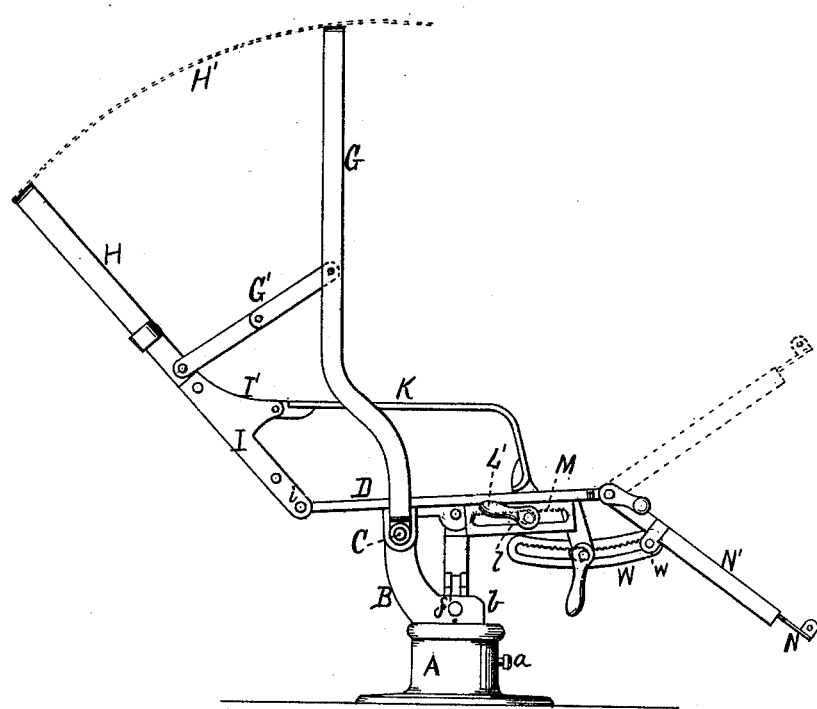

Fig. 4.

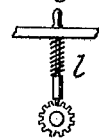

Fig. 2.

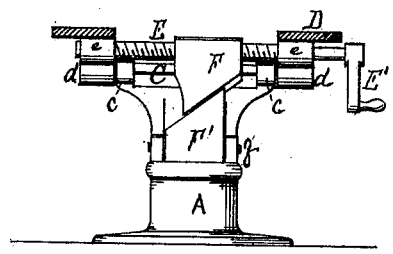
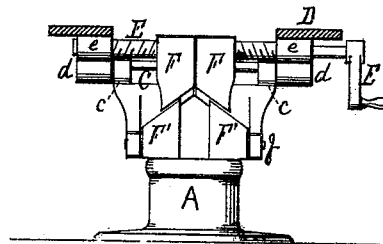

Fig. 3.



Witnesses,  
 W. H. Edward  
 Edwin James.

Inventor,  
 Thomas M. Brintnall.  
 per J. E. O. Holmead  
 Attorney.

T. M. BRINTNALL.  
RECLINING CHAIR.

No. 181,137.

Patented Aug. 15, 1876.

Fig. 5.

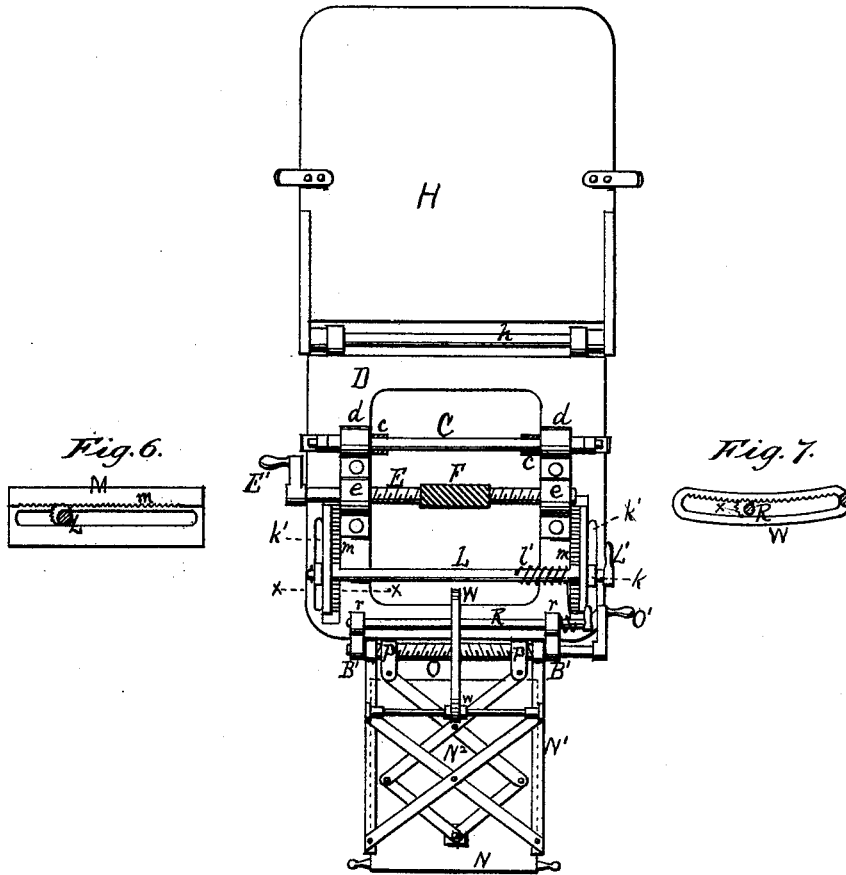
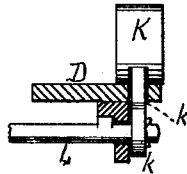

Fig. 8.



Witnesses;  
C. W. Howard  
Edwin James

Inventor;  
Thomas M. Brintnall.  
per J. E. J. Holmead.  
Attorney.

# UNITED STATES PATENT OFFICE.

THOMAS M. BRINTNALL, OF NEW YORK, N. Y., ASSIGNOR OF ONE-HALF  
HIS RIGHT TO JOHN GOODCHILD, OF SAME PLACE.

## IMPROVEMENT IN RECLINING-CHAIRS.

Specification forming part of Letters Patent No. 181,137, dated August 15, 1876; application filed  
April 26, 1876.

*To all whom it may concern:*

Be it known that I, THOMAS M. BRINTNALL, of the city and State of New York, have invented certain Improvements in Reclining-Chairs, of which the following is a full, clear, and exact description, reference being had to the accompanying drawing and the letters of reference marked thereon, making part of this specification, in which—

Figure 1 is a side view of my improved chair. Fig. 2 is a detached view of a portion of the working mechanism. Fig. 3 represents a modification of Fig. 2. Fig. 4 represents a modification of a portion of the locking mechanism. Fig. 5 is a bottom plan view, parts being removed. Fig. 6 is a side view of one of the slotted guides and toothed eccentric, by means of which the back is locked in position. Fig. 7 is a side view of the slotted guide for holding the foot-rest in position. Fig. 8 is a section on the line *xx*, Fig. 5.

The object of my present invention is to construct a chair so as to provide, although through different mechanism, all the advantages as to operating, adjustability, and locking of the hinged back and seat that are possessed by chairs described in my three several applications on file and now pending in the United States Patent Office. One of these additional features is the adoption and use of the improved means of operating the seat and back, in connection with means for supporting a curtain which can be so arranged as to secure the utmost privacy to the occupant of the chair, and another is the supplying a foot-rest susceptible of a double adjustment.

The first feature of my invention consists in providing a chair with standards terminating in a flat or bow top, substantially similar to the support of an ordinary buggy-top. This is to be so connected with the axle or pivot of either the back or seat of the chair as to permit of the free oscillation or swinging to and fro on its bearings. This frame is provided with a mechanism which shall control its operation in such a way as to permit of its being locked at any desired angle, and is so arranged as to cause it to be made a convenient support for a berth-curtain, or one which conceals the entire person of the occupant; or it may be a

simple or front curtain or duster extending down to and over the foot-rest, and, of course, the lower limbs of the occupant.

The second feature of my invention consists of a foot-rest provided with suitable bearings, to which are secured toggle-arms or lazy-tongs. These toggle-arms or lazy-tongs are operated by means of a right-and-left-hand screw and shank nuts. This right-and-left-hand screw may be attached so as to provide journal-bearings for the foot-rest to swing on, or it may be journaled below, and the rest pivoted or secured by any other suitable means to secure its rocking movement. The means alluded to secure the extension or withdrawal of the foot-rest in a longitudinal direction. Its elevation or lowering is secured by an arm or ratchet-rack secured on a shaft journaled in bearings, the lower bearing of this arm being secured on a suitable shaft in such manner as to cause it, through its movements, to impart the necessary tilting of the rest, whereby it can readily be elevated above the plane of the seat.

My present invention further consists in the mechanism through which the back is rendered adjustable, and moved and automatically locked at any desired angle. The arms of the chair are pivoted to its back by any suitable bearings, which are above the lower axle or pivot-bearings, on which the back swings. The forward or bow-shaped section of the arms terminates in shanks, which pass down through slots in the seat, and are keyed to a traveling axle, which works or moves in slotted bearings provided on the under surface of the seat. This axle is provided with a crank-handle, by which its movements are controlled, and locking-eccentrics, or ratchet rack and pawl, or ratchet-wheel, or other suitable device, is arranged in connection with the slotted bearings and traveling-axle, by means of which the axle can be securely held, and retained at any desired position of adjustment.

My present invention further consists in operating the seat, secured by suitable pivot-bearings, so as to tilt it to, and lock it at, any desired angle, by means of a screw journaled in suitable bearings below the seat, and a traveling wedge-plate bearing, the inclined

face of which meets or gears with a similar plate beneath it, the incline of which runs in the opposite direction to the incline of the upper plate, the lower plate being connected with the pedestal in such a manner as to allow of its rocking therein. If desired, these wedge-plates may be duplicated, in which case, of course, a right-and-left-hand screw would be substituted.

The construction and operation of my invention are as follows:

A is the pedestal, in the socket-bearing of which rests the standard of the head or support B. This support may be left free, so as to permit of the chair being rotated at pleasure; or it may be rigidly fastened by means of a screw, *a*, or other similar device.

The head or support B consists of a standard, *b*; and a projecting section, terminating in a slotted end, at the opposite sides of which are lugs *c c*. These lugs *c c* are each formed with an eye, which provide suitable journal-bearings for the shaft C.

D is the seat, and has cast or otherwise formed on its under surface lugs *d d*, which are also provided with eyes, through which pass the shaft C, which is rigidly keyed therein, so as to provide, in connection with the lugs *c c*, suitable rocking bearings for the seat. But I desire it distinctly understood that there is nothing arbitrary about the employment of the shaft C for this purpose, as the seat might be pivoted by means which would readily suggest themselves to any skilled mechanic, so as to operate as desired and entirely independent of the shaft C.

In suitable bearings *e e*, on the under surface of the seat C, is journaled, so as to allow of its free revolution, a screw, E, which is provided with a crank-handle, E', by which the screw is turned when it is desired to change the position of the seat. This screw E, in connection with wedge-shaped plates F F', forms the operating mechanism of the seat.

The plate F at its upper section is formed with an annular slot, in which is cut a female screw-thread, which fits over the screw E, and the plate is caused to travel to and fro on the screw, according to the direction in which the screw is turned. The lower plate F' is secured on a rocking shaft, *f'*, journaled in suitable bearings in the seat *b* of the support B.

The faces of these plates F F' may be plain; but I prefer that they should be tongued and grooved, as shown in Fig. 2.

The operation of this mechanism will be easily understood. When the crank E' is turned in one direction, the screw causes the plate F to travel down on the plate F', which causes the seat to incline toward the front, and when the crank is turned in the opposite direction, the plate F also travels in the opposite direction, and a reverse movement is imparted to the seat.

Instead of one set of plates, F F', being used, as shown in Fig. 2, they may be duplicated, as shown in Fig. 3, and the screw E in

this instance should be a right-and-left-hand screw, so as to impart the desired simultaneous movement to the duplicate traveling plates F F'.

The frame or support for the curtain may be of the form shown in the drawing, consisting of two vertical arms, G G, meeting and terminating in a bow top; or the arms may be entirely independent, and pivoted to either the back or seat, the essential features which must be observed being that they shall be so attached to some portion of the chair as to permit of their being extended or thrown forward to a suitable position to support the curtain, and when not in use folded back so as to be entirely out of the way.

In Fig. 1 these arms G G are journaled on the shaft C in a manner to allow of their free rocking or swinging motion; but, of course, they could be pivoted in various other ways to secure their oscillating movement. These arms G G, when extended, are locked or held in position by toggle-arms or pivoted levers G' G', as clearly shown in Fig. 1; but as these arms simply constitute, as it were, a locking mechanism for holding the uprights or frame G G in an extended position, as when supporting the curtain, a locking device at their base—such, for instance, as a ratchet attachment—might be substituted for them. Over these arms G G and the back H is secured a curtain. (Shown in dotted lines at H', Fig. 1.) This curtain may be of any desired pattern or style. It may be a berth-curtain, entirely encircling the chair, so as to offer entire privacy to the occupant; or simply a front sheet, extending down and over the feet of the occupant; or, it may be of the nature of a heavy comfort or blanket, which will be most desirable for night travel when my improvement is used as a sleeping-chair on railways.

The back H is secured to the seat by means of a shaft, *h*, or suitable pivot-bearings, in a manner to permit of the angle at which the back and seat shall rest being changed at pleasure. The means shown at Fig. 1 are the axle *h* and eyes *i i*, provided at the lower surface of lateral knee-bearings I I, secured to the sides of the chair-backs with their knees I' I' projecting in front. These bearings should be so constructed as to leave the knees I' I' as far above the eyes *i i* as is practicable, so that, in operation, the leverage on the same, due to the weight of the swinging back, may be reduced as much as possible, and the arms K K, which are pivoted to these knees I' I', may always be in position, as near as possible, parallel to that of the seat. These arms K K are rounded or bowed in front, so as to have at their lower ends a curved bearing or rest on the seat, and have projecting from their outer surfaces vertical shanks *k k*, as clearly shown in Fig. 8. These shanks pass through and travel freely in longitudinal guide or bearing slots *k' k'* in the seat. These shanks *k k* are attached at their base to a traveling shaft, L, which thus connects the two arms K. This shaft is oper-

ated by a crank-handle, L', and the shaft may be caused to work in slotted guides M M, as shown in Figs. 1 and 6, although these are not positively essential, as the rounded ends of the arms K will hold the shaft L in contact with the seat, and its locking mechanism *l* may, instead of being secured in the guides M, be attached directly to the under surface of the seat. This locking mechanism may consist of ratchet and spring pawl, as shown in Fig. 4, or a toothed eccentric engaging with the rack *m*, Figs. 5 and 6. The back is swung to any desired position simply by pushing on the crank L', which carries with it the shaft L, and it, through its connection with the arms K K, draws forward or pushes back the back H, as the case may be, when the crank being released, the locking mechanism employed will fasten the back in position. *l'* is a spring on the shaft L, and may be advantageously used for the purpose of keeping the locking mechanism in gear. The foot-rest consists of a plate, N, and grooved side arms N', the same being so connected that the plate shall slide freely in the arms in a longitudinal direction.

In lugs B' B', at the front of the seat-frame, is journaled a right-and-left-hand screw, O, which is worked by a crank, O'. On this screw is swung the foot-rest, and on the screw are also secured traveling shank-nuts P P, which are pivoted to the projecting ends of a system of toggle-arms or lazy-tongs, N<sup>2</sup>, secured on the under surface of the foot-rest plate. Of course, when the screw O is turned in a direction to cause the shank-nuts P P to travel toward each other, the toggle-arms are contracted at their upper section, and are extended longitudinally, and push out the plate N. When the screw O is turned in the opposite direction, the toggles are, of course, expanded in a lateral direction, and the plate N is drawn in. W is a slotted arm, secured in a suitable bearing, *w*, under the foot-rest, and working over a shaft, R, secured in bearings *r r* projecting down from the front of the seat. This shaft R is not for the purpose of elevating or lowering the foot-rest; but when the occupant elevates the same, even to such an angle as is shown in Fig. 1, which is a most comfortable form for smoking, &c., simply by turning the shaft R, an eccentric, *x*, Fig. 7, is brought in such direct contact with the inner face of the slot in the arm W as to securely

lock the same, and when it is desired to lower the rest the shaft is reversed, when the rest will fall through its own gravity; or, instead of the arm W, with its slot, an arm may be substituted with a straight or angular slot, and the slot may be toothed, or a ratchet-rack substituted, its teeth being caused to mesh or gear with a ratchet-wheel or pinion secured on the shaft R, in which case the shaft R, instead of becoming the locking device, would become the motor, and an independent locking device, such for instance as is shown in Fig. 4, might be most advantageously substituted, the same working in connection with a pinion on the shaft R.

What I claim as new, and desire to secure by Letters Patent of United States, is—

1. In combination with a reclining chair, having adjustable back and seat, the arms G G, and brace or toggle-arms G' G', the former being journaled to the shaft of the seat in such manner as to permit of their being thrown forward to support a curtain, and when not so used withdrawn and folded over the back of the chair, substantially as described.

2. The swinging back H, having knee-bearings I I', which project in front of the plane of the back, arms K K, having shanks *k k*, and shaft L, connecting said arms under the seat, the whole combined and arranged to operate substantially as described.

3. The combination of the hinged seat D and the plates F F', the same arranged to operate substantially as described.

4. The extension foot-rest, and a system of toggle-arms or lazy-tongs, N<sup>2</sup>, in combination with the right-and-left-hand screw O and traveling shank-nuts P P, the whole constructed and arranged to operate substantially as described.

5. A swinging foot-rest, having a pivoted supporting-arm, W, attached thereto, shaft R, and locking-eccentric *x*, the whole combined and arranged to operate substantially as described.

In testimony whereof I have signed my name to this specification in the presence of two subscribing witnesses.

THOMAS M. BRINTNALL.

Witnesses:

EDWIN JAMES,  
PHILIP F. LARNED.