

J. J. DALY.  
 WASHING-MACHINE

No. 181,146.

Patented Aug. 15, 1876.

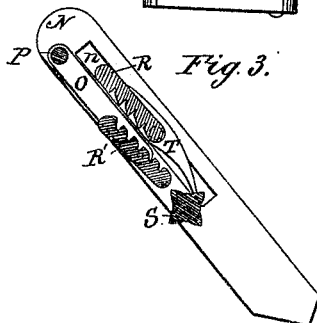
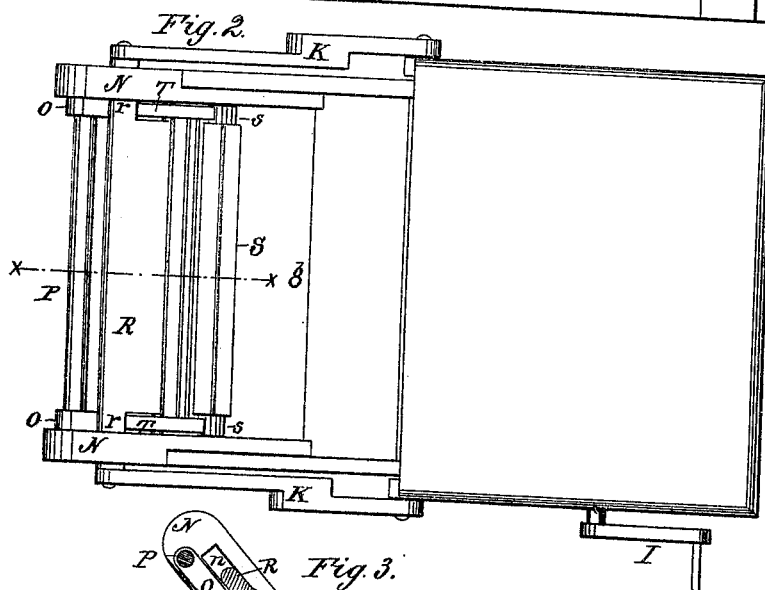
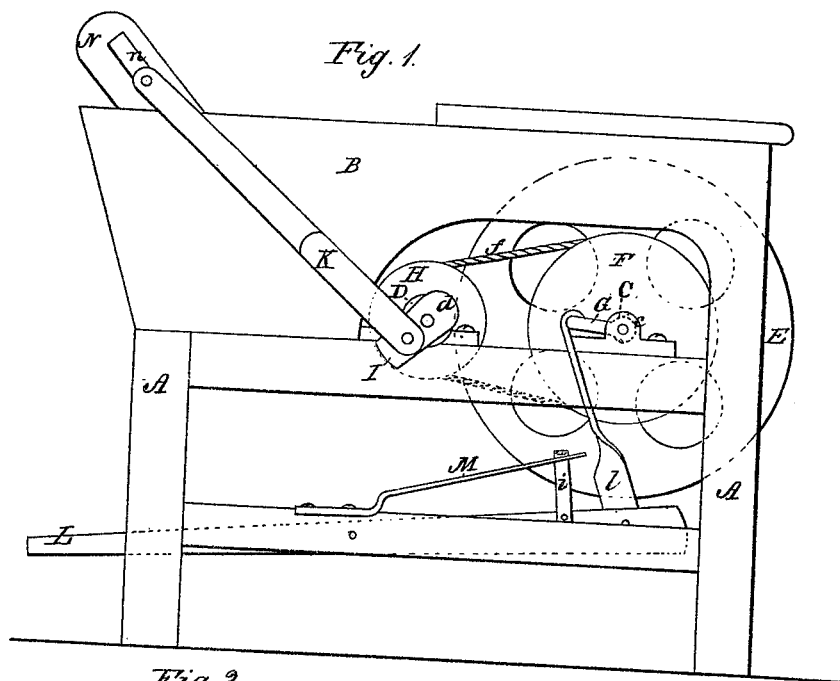

WITNESSES:  
*W. W. Hollingsworth*  
*J. G. Kimon*

INVENTOR:  
*James J. Daly*  
 BY *R. E. Kimon*

ATTORNEYS.

# UNITED STATES PATENT OFFICE

JAMES J. DALY, OF BLOOMINGTON, ILLINOIS.

## IMPROVEMENT IN WASHING-MACHINES.

Specification forming part of Letters Patent No. **151,146**, dated August 15, 1876; application filed June 17, 1876.

*To all whom it may concern:*

Be it known that I, JAMES J. DALY, of Bloomington, in the county of McLean and State of Illinois, have invented a new and Improved Washing-Machine; and I do hereby declare the following to be a full, clear, and exact description of the same.

In the drawings accompanying and forming part of this specification, Figure 1 represents a side elevation of my invention. Fig. 2 is a plan view of the same. Fig. 3 is a detail view of the wash-boards and attachments sectioned through the line *x x* of Fig. 2.

My invention consists in placing in a strongly-constructed wash-box two wash-boards with their ridged surfaces facing each other. The wash-boards stand between two parallel arms, which are fixed within at an inclination of about forty-five degrees to the sides of the wash-box. Their ends projecting above the box are provided with slots, in which projections on the upper corners of the upper wash-board travel, thus allowing the board to have a reciprocating motion. To the inner surface of each arm, and below the upper wash-board, is pivoted a short arm. The pivots are situated at the lower ends of the short arms, their upper ends being connected by a rail. Within the short arms, near their lower end, is pivoted the lower wash-board. Immediately below the two boards is a grooved roller, which has its bearings in the two inclined arms, and is provided with ratcheted ends, which are moved by pawls pivoted at the lower corners of the upper wash-board.

Motion may be communicated to the machine either by a crank-handle or by a treadle, as will be hereinafter more fully described.

In the accompanying drawings, A represents a strong frame-work containing the wash-box B, and provided at *cc* and *dd* with bearings for the two shafts C and D. The shaft C has on it the fly-wheel E, the fixed pulley F, and the crank G, and one of its ends projecting beyond its bearing is squared for insertion into a crank-handle, by means of which, when desirable, power may be communicated to the machine. The shaft D has fixed to it the pulley H, to which motion is imparted from the pulley F by means of a round belt, *f*; or a chain-belt may be used, the grooves

in the two pulleys being so formed as to accommodate the links of the chain. Each end of the shaft D projects beyond its bearing, and has fixed to it a crank, I, by means of which cranks and the connecting-rods K K the circular motion of the shaft is imparted as reciprocating motion to one of the two wash-boards, as hereinafter set forth.

To the lower part of the frame-work A is pivoted, through its middle point, the treadle L, the end of which is joined by the rod *l* to the crank G on the shaft C. Fixed to the treadle is the short upright *i*, the end of which is connected to the spring M, the latter being firmly secured to the frame-work A. By the action of the spring and upright the treadle is at all times prevented from stopping on a dead-center. The treadle is for use when doing light work. When heavy work is to be done the machine is run by the crank-handle.

Fixed within to each side of the wash-box are the two inclined arms N N, provided with slots *n n* in their projecting upper ends, and having pivoted to their inner surfaces the short arms O O. These short arms pivot at their lower ends, their upper ends being connected by the bar or rail P. Below the rail are the two wash-boards R and R', with their ridged surfaces facing each other, the upper board, R, moving up and down between the inclined arms, and being provided at its upper corners with the projections *r r*, which slide in the slots *n n*, and to which the connecting-rods K K pivot. The lower board, R', is pivoted at its center to the short arms O O. Below the wash-boards is the grooved roller S, having its bearings in the inclined arms, and provided with ratcheted ends *s s*, which are turned by the pawl T T, attached to the lower corners of the upper wash-board.

The machine being in motion, either by means of power communicated to the crank-handle or treadle, the wash-board R moves rapidly up and down over the opposing surface of wash-board R', which is held against the intervening clothes as loosely or tightly as may be necessary by varying the pressure upon the rail P, the latter acting by means of the pivoted arms O O. In most cases the pressure of the arms will be sufficient, and the hands will be left free for other employment.

When it is desired to release the clothes from the wash-boards, the pressure on the rail must be reversed, which, drawing the boards apart below, allows the clothes to be caught and dragged out by the grooved roller S, which is revolved by the pawls T T acting on the teeth of its ratcheted ends s s.

Having thus described my invention, what I claim as new, and desire to secure by Letters Patent, is—

1. In a washing-machine, the wash-boards R and R', in combination with the rail P and pivoted arms O O, substantially as and for the purpose herein set forth.

2. In a washing-machine, the wash-boards

R and R', the pivoted arms O O, and rail P, in combination with the pawls T T and grooved roller S, provided with ratcheted ends s s, substantially as and for the purpose herein set forth.

3. In a washing-machine, the shafts C and D, pulleys F and H, round belt f, cranks I I, and connecting-rods K K, in combination with the wash-boards R and R', the rail P, and grooved roller S, substantially as and for the purpose herein set forth.

JAMES J. DALY.

Witnesses:

ROBERT LOUDON,

JOHN MURPHY.