

A. HUMPHREY.
WIND-MILL.

No. 181,174.

Patented Aug. 15, 1876.

Fig. 1.

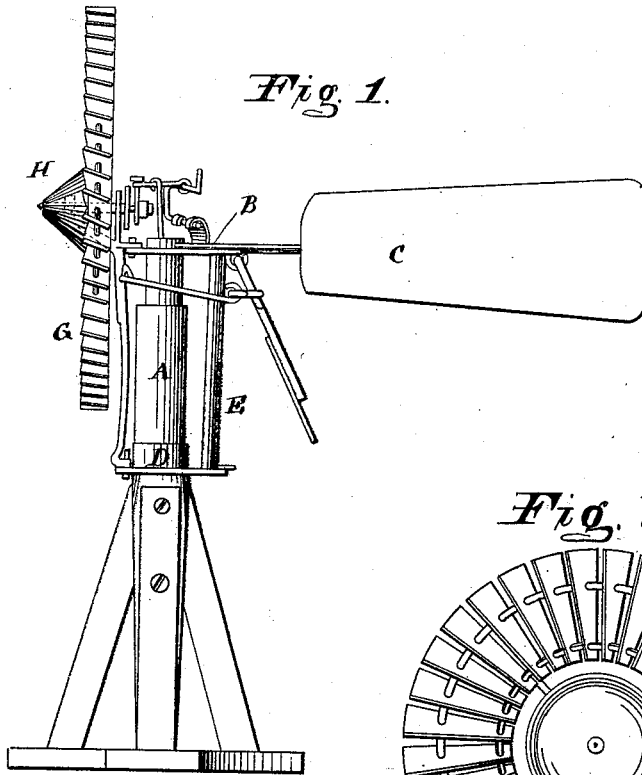

Fig. 2.

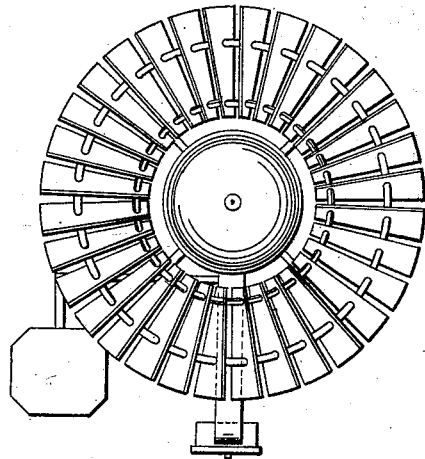
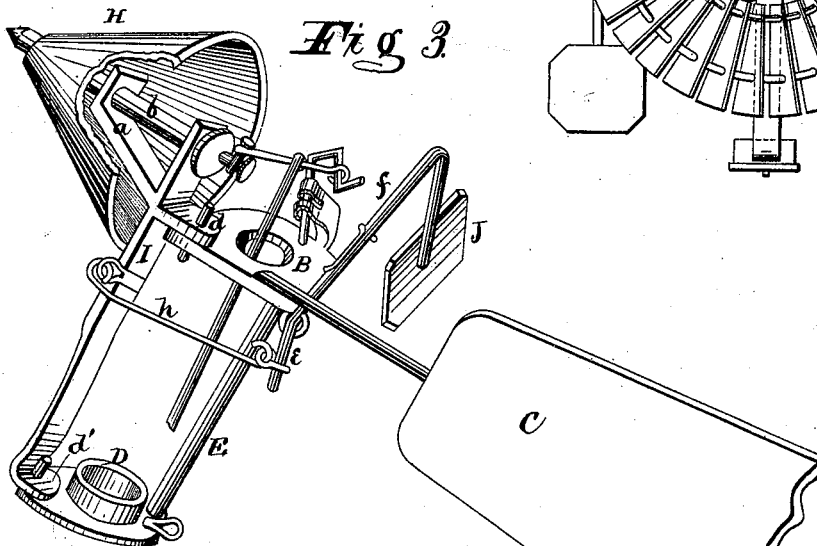

Fig. 3.



WITNESSES

H. Aubrey Goumin
H. N. Miller

INVENTOR

A. Humphrey
By Alexander M. ...
Attorneys.

UNITED STATES PATENT OFFICE

ARTHUR HUMPHREY, OF ARCOLA, ILLINOIS, ASSIGNOR OF ONE-HALF HIS
RIGHT TO JESSE W. GRISWOLD, OF SAME PLACE.

IMPROVEMENT IN WINDMILLS.

Specification forming part of Letters Patent No. **181,174**, dated August 15, 1876; application filed
June 7, 1876.

To all whom it may concern:

Be it known, that I, ARTHUR HUMPHREY, of Arcola, in the county of Douglas, and in the State of Illinois, have invented certain new and useful Improvements in Windmills; and do hereby declare that the following is a full, clear, and exact description thereof, reference being had to the accompanying drawings, and to the letters of reference marked thereon, making a part of this specification.

The nature of my invention consists in the construction and arrangement of a windmill, as will be hereinafter more fully set forth.

In order to enable others skilled in the art to which my invention appertains to make and use the same, I will now proceed to describe its construction and operation, referring to the annexed drawing, in which—

Figure 1 is a side elevation of my windmill. Fig. 2 is a front view of the wheel. Fig. 3 is a perspective view of the mill.

A represents the usual center tower. B is the turn-table, placed on the upper end of the center tower A, and having the rudder C bolted permanently thereto. A suitable distance below the turn-table, on the tower A, is a ring, D, connected with the turn-table by an arm or brace, E. G represents the wheel, provided with a hollow conical hub, H, projecting forward in front of the wheel, and attached to the front end of a center shaft, *b*, that has its bearings in the upper end of the wheel-staff I, and in an arm, *a*, projecting therefrom, said arm extending into the hollow conical hub, as shown in Fig. 3. By this construction the weight of the wheel is directly between the two bearings, whereby only short boxes for the journals need to be used, and consequently there is but little friction. The wheel staff or support I is, near its upper end, provided with a half-hinge, which connects with a similar half-hinge on the turn-table B, as shown at *d*, while the lower end of said staff or support is, by a hinge at *d'*, connected with the ring D on the center tower. By means of these hinges the wheel is enabled to turn almost square around, thus giving the governor complete control over its motions. It will be seen that by this construction of

the parts the wheel is permitted to remain very close to the center tower, therefore requiring only a short and light rudder to balance and hold it steady. *f* is a shaft, arranged at right angles with the rudder C, in one or more boxes on or under the turn-table B. At one end of this shaft is suspended the governor fan or vane J, and at the other end is a crank, *e*, connected to the wheel-staff I by a rod, *h*. When the wind blows hard enough it carries the fan or vane J back until it is in a horizontal position. In turning, the fan, by its connections, turns the wheel on its hinges until it is parallel with the rudder. When the wind slackens, the weight of the fan turns the wheel back at right angles with the rudder, the governor fan or vane thus serving the purpose of a weight and fan.

Having thus fully described my invention, what I claim as new, and desire to secure by Letters Patent, is—

1. The wind-wheel G, provided with the hollow conical hub H, in combination with the shaft *b*, staff I, and arm *a*, arranged so that the wheel will be between the two bearings, as and for the purposes herein set forth.

2. A wind-wheel secured to a shaft having its bearings in a staff or support hinged to the turn-table, substantially as and for the purposes herein set forth.

3. The combination of the turn-table B with rudder C, ring D, brace E, hinged staff or support I, with arm *a*, shaft *b*, and wheel G, with hollow conical hub H, all constructed substantially as and for the purposes herein set forth.

4. The combination of the suspended fan J, shaft *f*, with crank *e*, connecting-rod *h*, and hinged staff or support I, carrying the wheel G, substantially as and for the purposes herein set forth.

In testimony that I claim the foregoing I have hereunto set my hand this 29th day of November, 1875.

ARTHUR HUMPHREY.

Witnesses:

JOHN KILLGORE,
D. S. TROUT.