

W. EVANS.
ROLLS FOR ROLLING RAILS.

No. 181,255.

Patented Aug. 22, 1876.

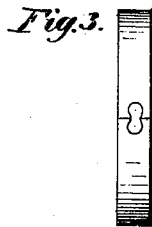
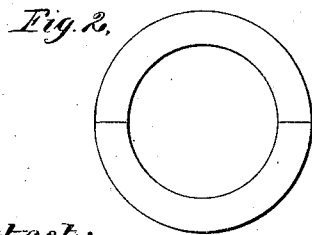
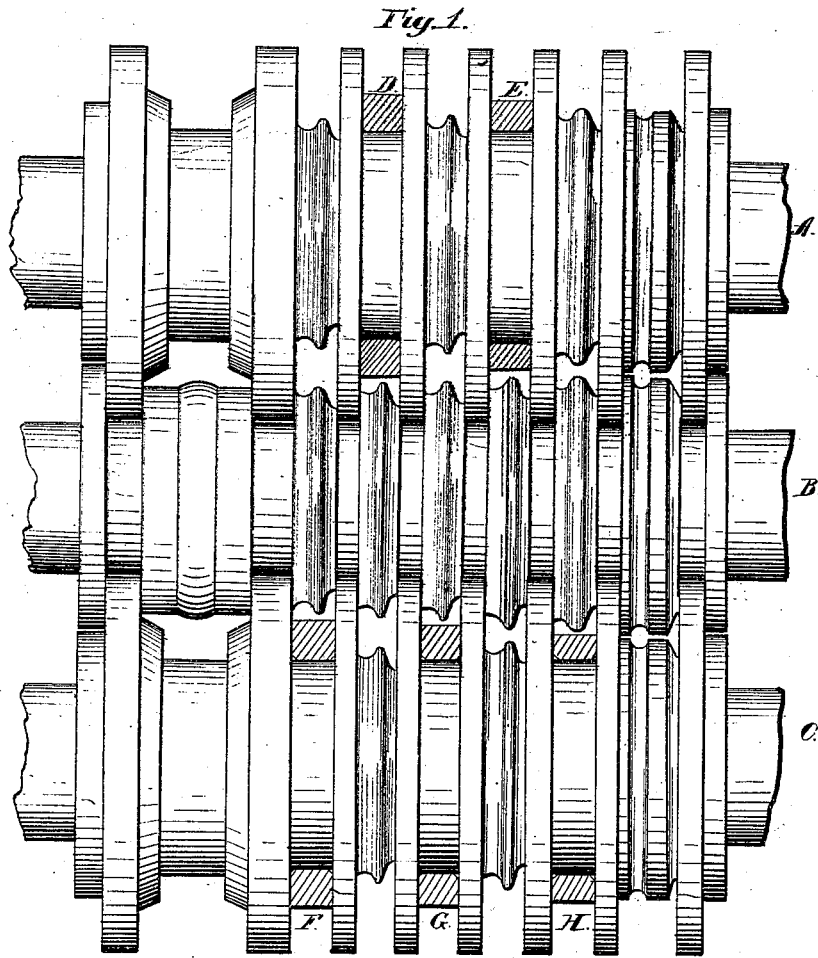

Attest:

R. H. Terhune.
Enoch Evans

Inventor:

William Evans.

UNITED STATES PATENT OFFICE.

WILLIAM EVANS, OF JOLIET, ILLINOIS, ASSIGNOR OF ONE-HALF HIS
RIGHT TO H. S. SMITH, OF SAME PLACE.

IMPROVEMENT IN ROLLS FOR ROLLING RAILS.

Specification forming part of Letters Patent No. **181,255**, dated August 22, 1876; application filed
May 27, 1876.

To all whom it may concern :

Be it known that I, WILLIAM EVANS, of Joliet, in the county of Will and State of Illinois, have invented a new and useful Improvement in Rolls for Rolling Steel Railway-Bars, which improvement is fully set forth in the following specification, reference being had to accompanying drawing.

The object of my invention is to utilize worn-out rolls for rolling solid steel railway-bars.

Figure 1 is an elevation of the usual type of the finishing-rolls in an American "three-high" train. It shows the arrangement of grooves which form a few of the "passes" by which, in the process of rolling, the pile or bloom is gradually reduced in sectional area and form until those of the finished bar are obtained. By use, these "passes" become rough, when they are smoothed in a turning-lathe—a process which, of course, reduces the diameter of the rolls until they speedily become too small for use, and also gradually enlarges the "passes," thus producing a bar of greater than the standard height, of any given pattern of rail. Mills require a set of these rolls for each pattern of rail; and when it is remembered that nearly every railroad demands a distinct form of rail, it will be seen that the renewal of these rolls, the combined weight of which in the finished state is equal to about ten (10) tons, costs a large sum.

By reference to the bottom roll C in Fig. 1, it will be seen its blanks, the spaces F, G, and H—grooves which perform no part in the shaping or rolling of the rail—correspond in their relative positions in the roll with that of three regular working-grooves, directly above

them, in the top roll A. Thus, when the "passes" in such a set of rolls become too much worn for use, the top roll can be made into a bottom one, and the bottom one into a top roll, when, with a new middle roll, B, they virtually become a new set.

I am well aware that this has long been the practice in iron-rail manufacture, but not in the manufacture of solid steel rails, except in instances where the collars between the grooves were made of extraordinary thickness. This involves much expense, requiring much longer rolls, and hence increasing the liability to break from transverse strain in the process of rolling. Long rolls are, moreover, not practicable in many of the existing mills of this class. In this interchange of rolls the collars between the grooves are greatly weakened by having the metal adjacent to them removed for the production of a new working-groove, and break when working solid steel. I strengthen these collars, and enable them to resist this new strain, by introducing a ring like that shown in elevations in Fig. 2 and Fig. 3, and in vertical section at D, E, F, G, and H in Fig. 1.

It will be remembered that these rings supply that which in the new and original roll would be a part of the solid casting, and therefore prove to be just as efficient in preserving the strength of the collar.

I claim as my invention—

The use of the ring, substantially as described, to resist the strain upon the collars.

WILLIAM EVANS.

Witnesses :

R. H. TERHUNE,
ENOCH EVANS.