

F. A. GLEASON.
NAIL-PLATE FEEDER.

No. 181,258.

Patented Aug. 22, 1876.

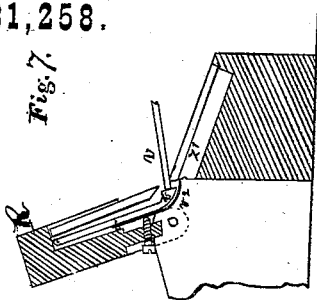

Fig. 7.

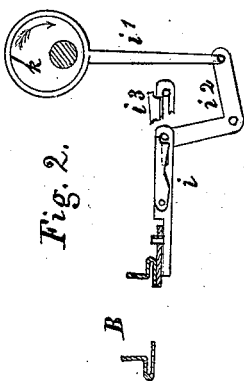

Fig. 2.

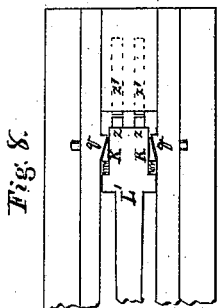

Fig. 8.

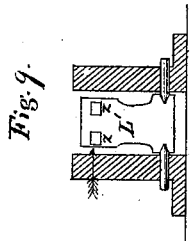

Fig. 9.

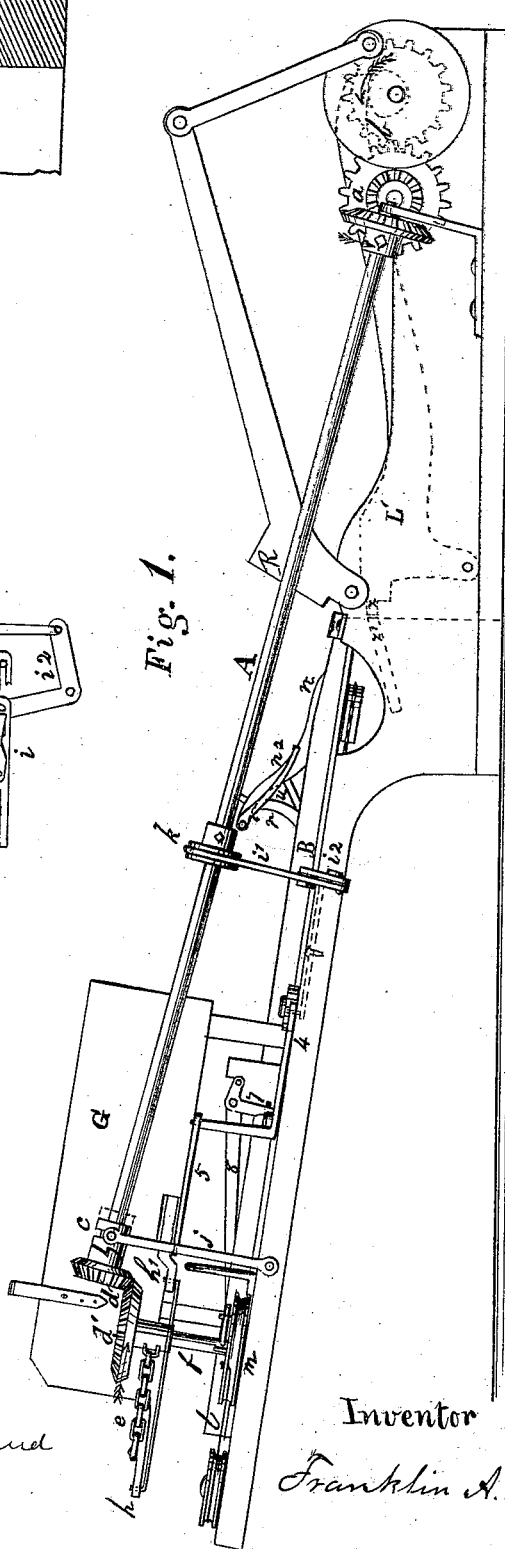

Fig. 1.

Witnesses.
Otto Shufeldt
W. Hauff

Inventor
Franklin A. Gleason

F. A. GLEASON.
NAIL-PLATE FEEDER.

No. 181,258.

Patented Aug. 22, 1876.

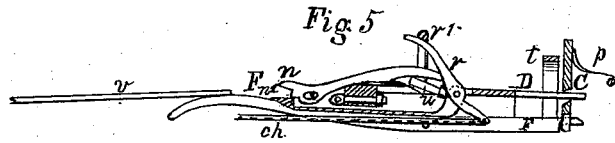
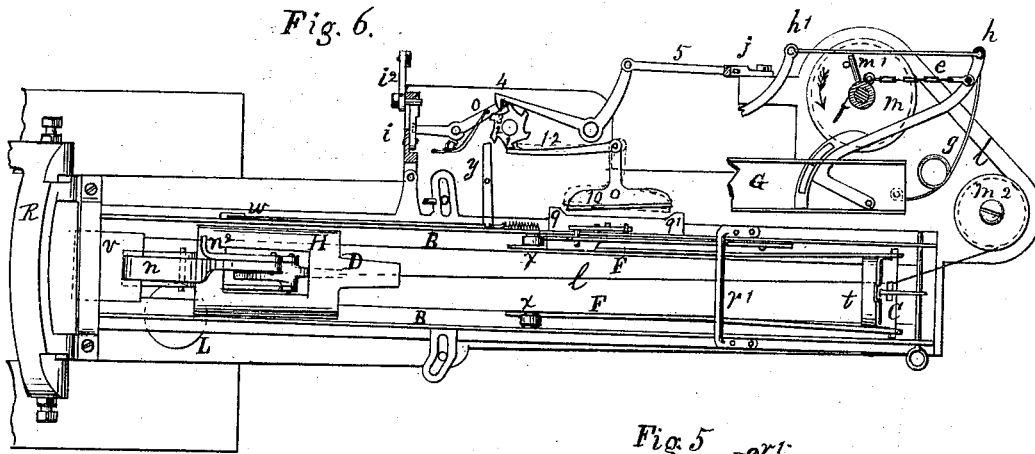
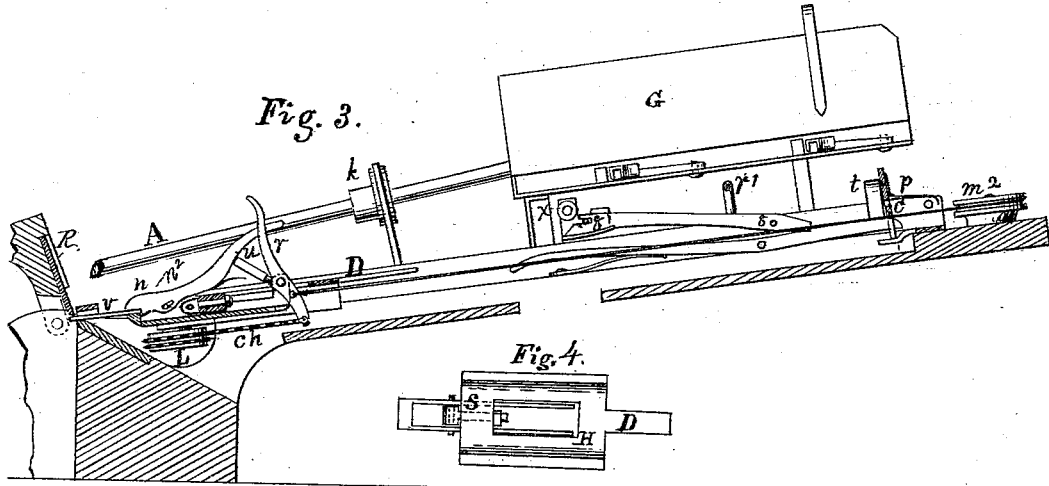

Witnesses.

Otto Shufeland.
W. Hauff

Inventor.

Franklin A. Gleason

UNITED STATES PATENT OFFICE.

FRANKLIN A. GLEASON, OF BROOKLYN, NEW YORK.

IMPROVEMENT IN NAIL-PLATE FEEDERS.

Specification forming part of Letters Patent No. 181,258, dated August 22, 1876; application filed October 4, 1875.

To all whom it may concern:

Be it known that I, FRANKLIN A. GLEASON, of the city of Brooklyn, county of Kings and State of New York, have invented an Improved Automatic-Feeding Nail-Machine, of which the following is a specification:

The object of my present invention is to improve the operation of the machine for which Letters Patent No. 85,522 were granted to me, bearing date January 5, 1869, by reference to which it may be seen that the discharge of plates from the plate-box and drawing back of the nipper were accomplished by means of a ratchet-bar, pawls, levers, connecting-rod, &c., operated by the cutting-lever, and consequently having reciprocating motion, which, at high speed, proved very uncertain in action.

In lieu of those I have substituted gear-wheels and rotary motion, operating the plate-carriers, drawing back the nipper, and operating the vibrator by a single shaft, A, connected with the driving-shaft by gear *a* *b*, as shown in the side elevation, Fig. 1, of the accompanying drawings. The opposite end of this shaft carries the clutch *c* and bevel-pinion *d*. A chain, *e*, connects the plate-carrier *h* with the shaft *f* of the bevel-wheel *d'*. On the lower end of this shaft is a grooved pulley, *m*, carrying a cord, *l* *l*, which connects with the nipper. (See plan view, Fig. 6.) These parts operate to draw back the nipper and discharge-plates from the plate-box G, and therefore act only at intervals, and when not in action the clutch *c*, which is feathered to the shaft, is thrown back to the position indicated by the dotted lines. An eccentric, *k*, upon the shaft A, (see detached transverse section, Fig. 2,) with its connections *i* *i*¹ and elbow *i*², produces a vibratory motion of the vibrator B. The connection *i* is in two parts, one being slotted where the wrist-pin of the elbow-lever enters, the other being a pawl, which, being dropped, motion of the vibrator is produced, or, being lifted, the motion is suspended.

In my former patent, the nipper was stayed open by a hinged stop, which was liable to be broken. I now construct the jaw *n* and stop *n*² in one piece. (See vertical section Fig. 3.)

The joint-pin hole being slotted, the jaw is stayed open by sliding a little forward over the lower jaw. (See Fig. 5.)

Fig. 4 is a plan view of the nipper-slide H and the lower jaw of the nipper, showing the universal joint S, by which they are connected, so as to allow the nipper to adapt itself to crooked and winding plates.

The detent heretofore used for detaining the nipper when drawn back to receive the plate, proving very uncertain in its action, I have substituted therefor the friction-clutch C, bar D, and double lever F F. (Shown in detached vertical section, Fig. 5, and plan view, 6.) These levers are connected together at the back end by the bow-shaped piece *t*, so that their action shall be simultaneous. Against the ends of these levers the foot of the clutch C rests, the top being pressed toward the bow *t* by the spring *p*. The main spring-barrel L carries a chain, *ch*, Fig. 3, which connects with the lower end of the lever *r*, the arm *u* of which serves as a cam to shut the nipper, the chain impelling it constantly toward the barrel.

Its operation is as follows: As the plate *v* is being cut away, the nipper, being impelled by the mainspring L, passes toward the cutter until the nipper-slide H, Fig. 6, comes in contact with a hook of the bar *w*, which connects with one end of the lever *y*, carrying the opposite end within tooth 2 of the ratchet-wheel. The next motion of the vibrator B B being toward the wheel, tooth 3 is carried past the hook of the elbow 4, forcing it outward. The lever *o*, the end of which is bent upward just within the hook 4, is also carried outward by the same tooth, and, the wheel stopping, holds it there. The opposite end of this lever *o* extends under the pawl of the connection *i*, and, being thus carried backward, comes in contact with the oblique bottom of the pawl, (see *i*, Fig. 2,) throwing it up as it passes to the position *i*³, allowing the wrist-pin to return within the slot, thereby arresting the motion of the vibrator until another plate is delivered to it. The outward motion of elbow 4 (mentioned above) through the connection 5 and lever *j*, Fig. 1, connects the clutch *c* with the pinion *d*, which, winding the chain *e*, causes the plate-carriers *h* *h*¹ to carry the lowest plate

out at the opposite side of the plate-box. Simultaneously with the above, an arm, m^1 , Fig. 6, in the shaft f , carries the pulley m , winding up the cord l , drawing the nipper backward until the bar D enters the clutch C . (See Fig. 5.) In passing to this position the lever r , coming in contact with the cross-bar r^1 , is thrown down, opening the nipper and discharging the scrap of plate, which falls through an opening in the feeder-table. The nipper-slide H , also, in coming to this position, passes under the short arm of the lever 8, Fig. 3, and, lifting it, throws down the opposite end, which, by the elbow-connection 7, Fig. 1, carries the oblique projection 9 (Fig. 6) of the sliding plate backward or to the right, forcing outward the arm of the T-lever 10, drawing back the bar 12 to within tooth 1 of the ratchet-wheel. (See dotted lines.)

Just at the point where these motions are all completed an arm of the plate-carrier h^1 , Fig. 1, comes in contact with the lever j , disconnecting the clutch c from the pinion d , when the spring g , Fig. 6, throws back the plate-carriers, dropping the plate into the vibrator. The grooved pulley m , being loose upon its shaft, and carried by the arm m^1 , is not thrown back, but remains to be drawn back as the nipper gradually runs down. A guard surrounds it, and also the pulley m^2 , to keep the cord in position.

When the plate is dropped it falls upon the rollers x and cross-bar r^1 , Figs. 3 and 6, and sliding down toward the cutter, and dropping off the rollers into the vibrator, falls upon the double lever F F , depressing which, the opposite ends are lifted, allowing the foot of the clutch C to pass under and forward until its top is arrested by the bow t , and releases the bar D . The nipper then springs forward to the plate v , Fig. 5, which, passing between the jaws, strikes against the stop n^2 , and forcing it backward off from the lower jaw, the nipper closes upon the plate and carries it into the cutters.

A fly-lever, n^2 , Fig. 1, is loosely pivoted to the back end of the upper nipper-jaw n , the lower end being bent outward, n^2 , Fig. 6. Just in the position where the nipper closes upon the plate, this bent arm is passing under a flange, $8'$, of the lever 8, Fig. 3. The arm u , in closing the nipper, throws up, also, the fly-lever, carrying with it $8'$, which, by elbow 7, carries the sliding plate with its oblique projection 9' downward or to the left, which, by reversing the T-lever 10 and bar 12, throws the ratchet-wheel a little forward, and releases the lever o , which, being thrown down by its spring, drops the pawl i , Fig. 2, and vibratory motion of the vibrator is resumed.

The fly-lever n^2 will lift the lever $8'$ only when the nipper-jaw is held rigid by grasping a plate. The object of this is that vibratory motion shall not commence except the

nipper fastens upon a plate. Disaster is thus avoided should a plate fall in wrong.

In hand-fed machines the speed is such that they are cleared simply by gravitation; yet sometimes a nail is found to stick in the dies.

To insure clearing at all times, even with high speed, I provide a clearing-spring, v^2 , Fig. 7, by extending the gage-spring down, and curving it under the end of the gage v . In the upward motion of the cutter-lever R the gage is thrown forward against the bed-cutter, and the spring falls backward. On the opening of the cutters the plate v enters, forcing the gage backward, which throws forward the clearing-spring, which, in its downward motion, carries before it all that may not have fallen out.

The die-lever L' , (see plan view, Fig. 8,) which carries the moving dies z z , is operated by a cam, b , on the main shaft. (See dotted outline, Fig. 1.) As the lever L' rises the nail is caught between the moving dies z z and bed-dies z' z' , and held for heading. The header (not represented in drawing) being brought to bear upon it in the position and direction of the arrow, Fig. 9, produces a lateral motion of the moving dies, while the bed-dies remain fixed. This causes a sliding of the nail between the dies, wearing them rapidly, and, also, making the head unequal in thickness.

To prevent as much as possible this lateral motion, it is customary to set the centers very close, so close even as to exclude oil; but this has only partial effect.

To remedy this defect, I provide bearings q q , Fig. 8, upon the inside of the frame having an incline of, say fifteen degrees, more or less, from the line of motion, and in the spaces between these and the sides of the die-lever, which are parallel, I insert the wedges K K , with springs behind them, which force them in sufficiently to hold the die-lever steady laterally, and yet allow free motion longitudinally.

I claim as my invention—

1. The combination, with the nipper and nipper-slide, of the nipper-jaw n , provided with projecting stop n^2 , and slotted pin-hole and universal joint s , substantially as herein shown and described.

2. The friction-clutch C and nipper-slide H , with projecting bar D , in combination with the double lever F F .

3. The clutch c , bevel-gears d d' , chain e , plate-carriers h h' , pulley m , and cord l , substantially as combined with the shaft A .

4. The combination of the eccentric k , connection and pawl i , connection i^1 , and elbow i^2 , with the shaft A and vibrator B .

5. The bar w , lever y , ratchet-wheel and lever o , as combined with the pawl i , and operated by the nipper-slide H for arresting vibratory motion.

6. The lever 8, elbow 7, sliding plates 9 9', T-lever 10, and bar 12 combined with the fly-lever n^2 and nipper-jaw n , for reproducing vibratory motion.

7. The combination of the inclined bearings $q q$ and wedges $K K$ with the die-lever L .

8. The combination of the clearing-spring

v^2 with the gage v and cutter-lever R , substantially as herein shown and described.

FRANKLIN A. GLEASON.

Witnesses:

W. HAUFF,

OTTO HUFELAND.