

J. C. McLAREN & C. B. COVENTRY.
SHARPENING-MACHINE.

No. 181,275.

Patented Aug. 22, 1876

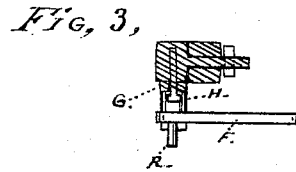
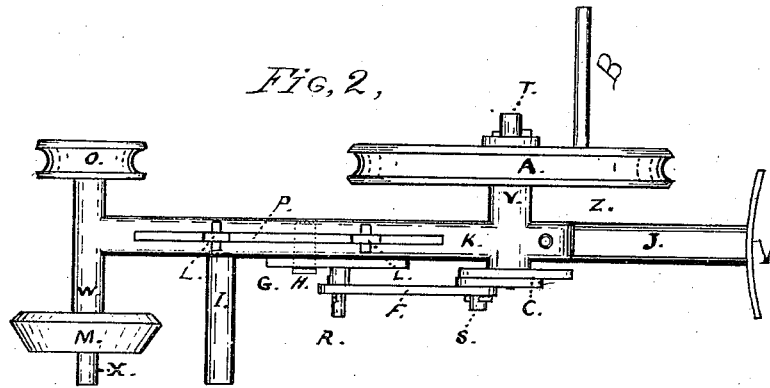
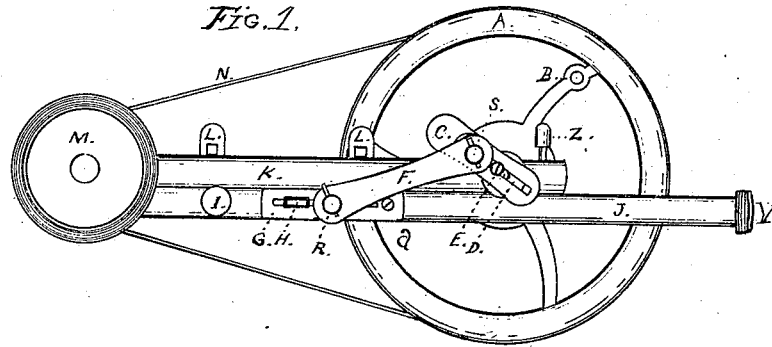

WITNESSES,

John H. Redstone.
Walter Hyde

James C. McLaren
Charles B. Coventry.

UNITED STATES PATENT OFFICE.

JAMES C. McLAREN AND CHARLES B. COVENTRY, OF SAN FRANCISCO, CAL.

IMPROVEMENT IN SHARPENING-MACHINES.

Specification forming part of Letters Patent No. 181,275, dated August 22, 1876; application filed June 17, 1876.

To all whom it may concern:

Be it known that we, JAMES C. McLAREN and CHARLES B. COVENTRY, both of the city and county of San Francisco and State of California, have invented certain new and useful Improvements in Machinery for Grinding and Sharpening Sickle-Teeth for Reapers and Mowers, of which the following is a specification:

Figure 1 is a side elevation; Fig. 2, a plan view; and Fig. 3, a section, showing the construction of the same.

The following is the construction of the same: A represents the main driving-wheel; B, the handle; C, the adjustable crank-arm; D, the slot for adjusting the crank; E, the set-screw; F, the connecting-bar; G, the slotted movable set-block; H, the guide for the movable set-block; J, the bed bar or frame; K, the sliding frame; L, the guide-posts for the sliding frame; M, the grinding-wheel; N, the driving-belt; O, the small driving-pulley; P, the slot to allow the motion of the sliding bar of the crank; R, the pin to attach the connecting-rod F with the sliding set-block; S, the crank-pin; T, the main driving-shaft; V, the main sleeve-journal bearing for the main shaft; W, the sleeve-journal bearing for the grinding-shaft X. The set-pin Z is designed to set the sliding frame K upon the bed bar or frame J, the breast-plate to be held against the breast when the machine is being operated.

The following is the operation of the same: As the hand-wheel A is revolved, motion is imparted to the pulley O, which, being on the shaft X, (which operates in the sleeve W,) gives motion to the grinding-wheel M, which is also attached to the shaft X.

The crank C, being attached to the shaft T, which operates in the sleeve V, which forms a part of the sliding frame K, causes the same to reciprocate, when the sliding set-block G is set fast to the frame J by means of the set-screw *a*, (the set-pin Z being withdrawn to allow the same to move.) Thus, the frame K being moved back and forth the depth of the sickle-tooth, (to which it is adjusted by adjusting the crank C, as indicated

by the slot D,) moves the grinding-wheel M along the whole cutting-edge of the sickle-tooth, thus saving the motion of the body of the operator necessary to effect the same.

In case the grinding-wheel is designed to be held still in one position, as would be the case when a nick is required to be ground out of a tooth, or a portion of the tooth ground off at one point, then the set-screw *a* is withdrawn, freeing the sliding set-block G, and allowing the same to reciprocate, sliding upon the guide-post H, maintaining the grinding-wheel M steadily in one position; and in case it is necessary to use it continuously in a fixed position, then the compound slotted crank C is adjusted to bring the crank-pin S directly in line with the center or axis of the shaft T, thus entirely neutralizing the effect of the crank C, while the set-pin Z holds the frame solidly together, and gives the effect of a solid machine. The slot P and guide-posts L L represent the attachment of the sliding frame K with the bed-frame J, so as to allow the required reciprocating movement.

The advantages of this over all other sickle-grinding machines is seen in its entire adjustability, which adapts it to any kind of work required in sharpening sickle-teeth in the field, or without detaching the sickle from the reaper or mower.

The combination of the adjustable crank with the sliding frame is used to reciprocate the same, or when the same is made stationary it is there neutralized either by freeing the sliding set-block G and allowing it to slide upon the guide-post H, or by bringing the crank-pin on the axis of the main driving-shaft T; and the sliding set-block G is either used as the fulcrum for the lever-connecting bar or rod F, by which the frame K is reciprocated or moved backward and forward, or is allowed to slide, as has been shown.

The machine can be adjusted to any angle or bevel, being controlled entirely by the hand and body of the operator. The grinding-shaft X is fixed in position in relation to the sliding frame K as it revolves in the sleeve W, which has no adjustment in relation to the sliding frame K.

What we claim, and desire to secure by Letters Patent, is—

The sickle-sharpener, to operate either fixed or reciprocating, composed of the bed-frame J, having the bearing-plate Y, the handle B, the guide-post H, and the guide-posts L and L, and the reciprocating frame K, having the sleeves V and W, the slot P, and set-pin Z, in combination with the adjustable

crank C, the connecting-rod F, and sliding set-block G, when constructed and operated, substantially as and for the purposes set forth.

JAMES C. McLAREN.
CHARLES B. COVENTRY.

Attest:

J. H. REDSTONE,
WALTER HYDE.