

E. S. STIMPSON.

LOOM TEMPLE.

No. 181,291.

Patented Aug. 22, 1876.

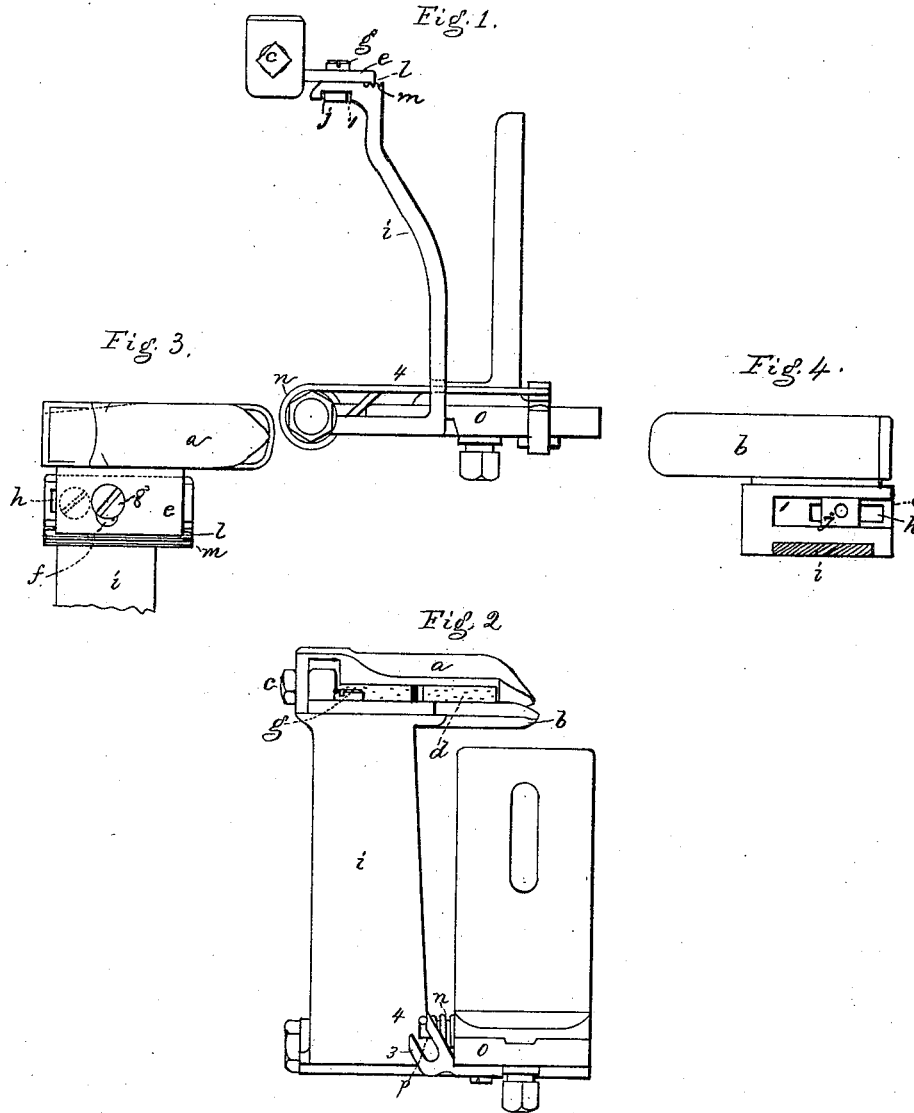

Witnesses.
L. H. Bates,
W. J. Pratt.

Inventor.
Edward S. Stimpson
per Crosby & Gregory Attys.

UNITED STATES PATENT OFFICE.

EDWARD S. STIMPSON, OF HOPEDALE, MASSACHUSETTS, ASSIGNOR TO
DUTCHER TEMPLE COMPANY, OF SAME PLACE.

IMPROVEMENT IN LOOM-TEMPLES.

Specification forming part of Letters Patent No. **181,291**, dated August 22, 1876; application filed
April 10, 1876.

To all whom it may concern:

Be it known that I, EDWARD S. STIMPSON, of Hopedale, county of Worcester, State of Massachusetts, have invented an Improvement in Loom-Temples, of which the following is a specification:

This invention relates to temples for looms, and is an improvement on the temple shown in application of W. W. Dutcher, filed in the United States Patent Office, March 10, 1876; and consists in the combination, with the carrier for the temple-head and its spring; of a spring-shifter, to automatically disengage the spring from the carrier when the latter is moved back against the breast-beam.

Figure 1 represents the temple in side view; Fig. 2, a front view, looking from the breast-beam toward the lay; Fig. 3, a top view of the head and carrier; and Fig. 4 is an under-side view thereof.

The carrier *i*, stand, and plate *o* are the same as the corresponding parts in the application above cited, and such parts need not, therefore, be described.

The cap *a* of the temple and the trough *b* are of usual construction, and the rod or stud *c* supports an ordinary toothed roller, *d*, in the usual manner, and the plate *e*, projecting from the trough, is slotted, as usual, at *f*, to receive a screw-bolt, *g*, by which the plate *e* is secured to the carrier *i*, and the slot permits adjustment of the temple-head in the direction of the reed. To provide for adjustment of the temple-heads transversely, so as to adapt them to each selvage of the warps or woven cloth, I provide the upper portion of the carrier *i* with a longitudinal slot, *h*, and a grooved way, *l*, to receive the shank and nut *j* of the screw of bolt *g*, and when the bolt is loosened the plate *e* and head may be easily moved on the carrier toward or from the selvage, and avoid adjusting the temple-frame on the breast-beam. The plate *e* has a lip, *l*, at one edge to enter one of the grooves *m* in the top of the carrier, to guide the plate in a direct line, and prevent the lateral displacement of the head.

It is obvious that the lips on the carrier-top might enter grooves in the plate *e*, and the lips and grooves might be omitted altogether.

The screw *g*, instead of being placed as

shown, may be located farther toward the outer side of the plate *e*, as in dotted lines, Fig. 3, and then, when it is desired to loosen the screw *g*, the screw-driver may be inserted in the slot of the screw without lifting or straining the warps at the selvage.

The spring *n*, wound about a hub or sleeve on the carrier, and a hub on the plate *o*, has its longest or free end extended backward to engage a holding-notch in, or it might be a projection on, the carrier *i*, to retain the latter pressed forward toward the lay. The free end of this spring is extended back far enough to terminate above or to enter an inclined passage between two inclined walls, 3 4, of the spring-shifter, and when the temple carrier-bar is turned or thrown back beyond the point at which it is moved by the lay in its usual regular motion, as when it is desired to turn the carrier back away from the reed to correct imperfections in the weaving, then the free end of the spring enters the inclined slot in the shifter, and the spring, moved laterally by the wall 3, is thrown out of engagement with the carrier-notch, thereby permitting the temple-head and carrier then released from the action of the spring to be turned back against the breast-beam, where it will rest; but when the carrier is again moved forward toward the lay, the spring springs into the notch made for it in the carrier, and engages and holds the carrier pressed forward to be moved by the lay, as usual.

In the Dutcher application, herein referred to, this spring had to be disengaged from, and engaged with, the carrier by hand; but, through the action of the spring-shifter, this hand manipulation of the spring is obviated.

This spring-shifter is herein shown attached to the plate *o*; but it is obvious that it might be connected with other parts of the temple-frame, and its shape might be changed without departing from my invention in this particular, the gist of which is, the automatic lateral movement of the spring to disengage it from the carrier as it is moved back against the breast-beam farther than when moved by the lay acting as usual, and the spring, relieved from the carrier-notch, is held by the shifter ready to again engage the notch in the

carrier, when the latter is again moved up to the reed.

It is obvious that parts of my invention may be applied to ordinary temples, wherein the carrier reciprocates in a right line.

I do not broadly claim a temple provided with a spring and so combined with the carrier of the temple-head that backward motion of the carrier will negative the action of the spring as a forward-moving spring, for a carrier with such a construction of devices is shown in an application made by Nathan Chapman.

In case it is desired to set the temple-head at an angle to the breast-beam, to stretch the woven fabric at the cloth-making point, the face of the temple-head next the reed may be beveled or cut away, as shown by dotted line *x*, Fig. 3.

I claim—

1. The temple-head and its plate provided

with a lip, in combination with the carrier, slotted to receive screw or bolt *f*, and grooved to receive the lip, substantially as described.

2. The combination of a temple-head, carrier, and its spring, with a spring-shifter adapted to move the spring laterally to disengage it from the carrier, and to hold the spring when the temple is moved back, substantially as described.

3. The pivoted carrier, provided with a side notch, in combination with the spring-shifter, adapted to remove the spring out of the notch in the carrier.

In testimony whereof I have signed my name to this specification in the presence of two subscribing witnesses.

EDWARD S. STIMPSON.

Witnesses:

F. J. DUTCHER,
W. W. DUTCHER.