

G. H. WALLACE.

WIND-MILL.

No. 181,293.

Patented Aug. 22, 1876.

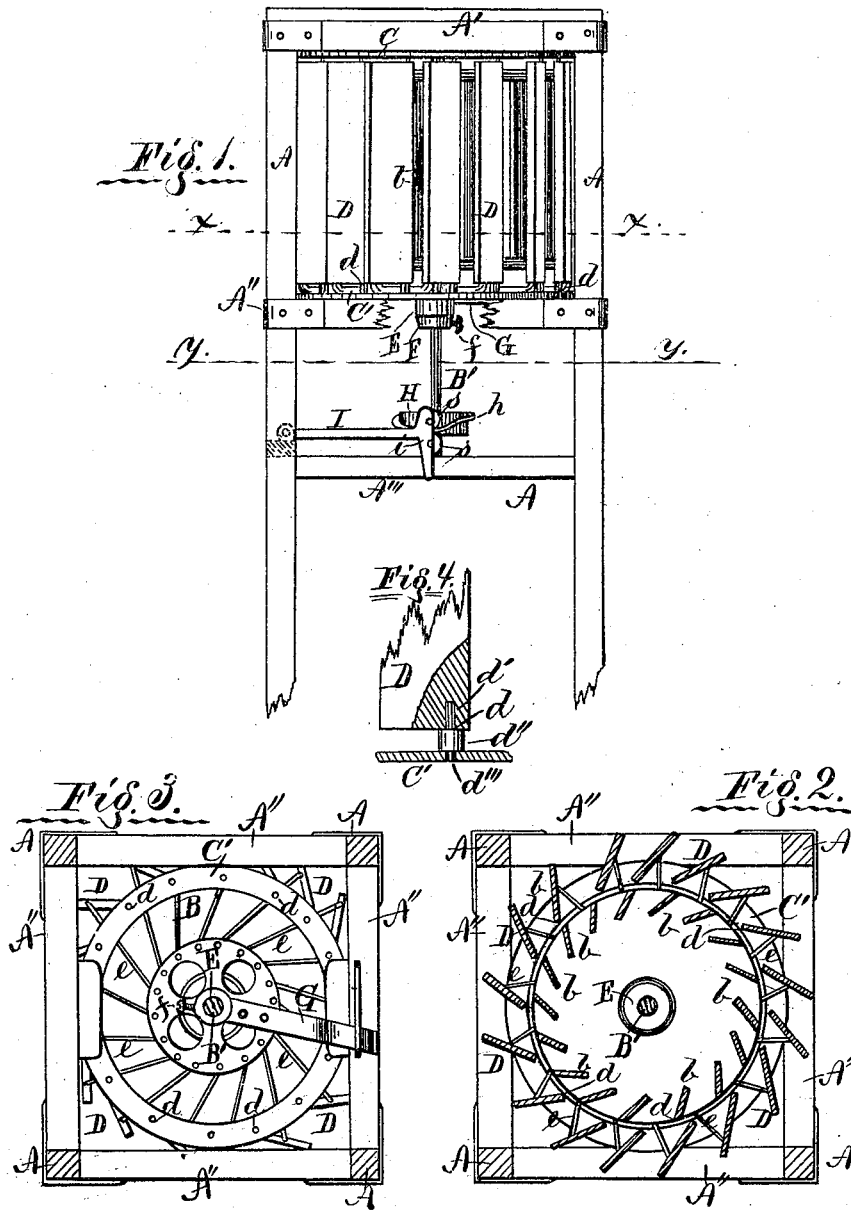

Witnesses:
M. H. Barringer
Cha. Luffman

Inventor:
George H. Wallace,
By W. B. Richards
Atty.

UNITED STATES PATENT OFFICE.

GEORGE H. WALLACE, OF NEWTON, IOWA.

IMPROVEMENT IN WINDMILLS.

Specification forming part of Letters Patent No. **181,293**, dated August 22, 1876; application filed May 24, 1876.

To all whom it may concern:

Be it known that I, GEORGE H. WALLACE, of Newton, in the county of Jasper and State of Iowa, have invented certain new and useful Improvements in Windmills; and I do hereby declare that the following is a full, clear, and exact description thereof, which will enable others skilled in the art to which it appertains to make and use the same, reference being had to the accompanying drawings, and to letters of reference marked thereon, which form a part of this specification.

My invention relates to improvements in windmills, of that class in which the wind-wheel rotates on a vertical axis, and is surrounded by a series of shutters, which may be closed to shut off the wind entirely from the wheel, and opened to act as directrices for the wind to the wheel; and the invention consists in certain new and improved devices and combinations of devices, whereby the operation of the wind-wheel is rendered more effective and easy to regulate, all as hereinafter more fully set forth.

In the accompanying drawing, Figure 1 is a side elevation of a windmill embodying my invention. Fig. 2 is a sectional view in the line *x x* of Fig. 1. Fig. 3 is a sectional view in the line *y y* in Fig. 1, looking upward; and Fig. 4 is a section through one of the shutters, and its hinge.

Referring to the parts by letters, letters A represent the frame-work of the structure on which the motor rests, consisting of posts A and transverse frame-pieces A' A'' A'''. B is the wind-wheel, mounted on a central vertical, B', having suitable bearings in the bars A' A'' A''', and carrying sails *b*, as shown plainly at Fig. 2. C C' are annular plates, secured to the frame-pieces A' A'', the one, C, above, and the other, C', below the wheel B. D represents the shutters hinged at *d* on their inner edges to the plates C C', the lower hinge formed, as shown at Fig. 4, of a journal, *d'*, which enters the lower end of the shutter, a collar, *d''*, on which the shutter is supported, and an end, *d'''*, which enters the plate C'. The shutters D are hung so that their inner edges come very near the periphery of the wheel B, and, being hinged very near their edges, chang-

ing their angle does not affect their distance from said wheel; hence, opening them at a greater or less distance does not increase the annular space between them and the wheel, and thus open a passage for the air inoperative upon the wheel. E is a circular plate, journaled on the shaft B' above a collar, F, which is secured upon the shaft by a set-screw, *f*. Letters *e* are arms or rods, pivoted at one end in the plate E, and their other ends pivoted one to each lower end of the shutters D, so that rotation of the plate E will open and close the shutters. G is an arm attached to the plate E, and extending outward beyond the supporting-frame A. H is a pulley or wheel on the shaft B', on the periphery of which is a serpentine cam-shaped projection, *h*. I is an arm pivoted or hinged at one end to the side of the frame A, and its other end formed into a T-shaped head, *i*, carrying pulleys *s s*, between which the cam *h* operates, so that a rotary motion of the shaft B' will impart an oscillating movement to the arm I, and through it transmit a reciprocating motion to a pump-rod, or any desired device connected with it.

By removing the cam *h* a belt may be used to transmit motion from the pulley H. The rod or arm G may be used to turn the plate E to entirely close the shutters, or to set and fix them at any desired degree of opening.

Having thus described my invention, what I claim as new, and desire to secure by Letters Patent, is—

1. The hinges for the shutters D, constructed as described, with a journal, *d'*, collars *d''*, and end *d'''*, for operation with said shutters D and plate E, substantially as and for the purpose specified.

2. The cam-wheel H, arranged to operate with the wind-wheel B and arm I, carrying studs *s*, with or without pulleys, substantially as and for the purpose specified.

In testimony that I claim the foregoing as my own I affix my signature in presence of two witnesses.

GEO. H. WALLACE.

Witnesses:

THOS. A. MCKEE,
H. E. HUNTER.