

P. L. WEIMER.
BLOWING ENGINES.

No. 181,295.

Patented Aug. 22, 1876.

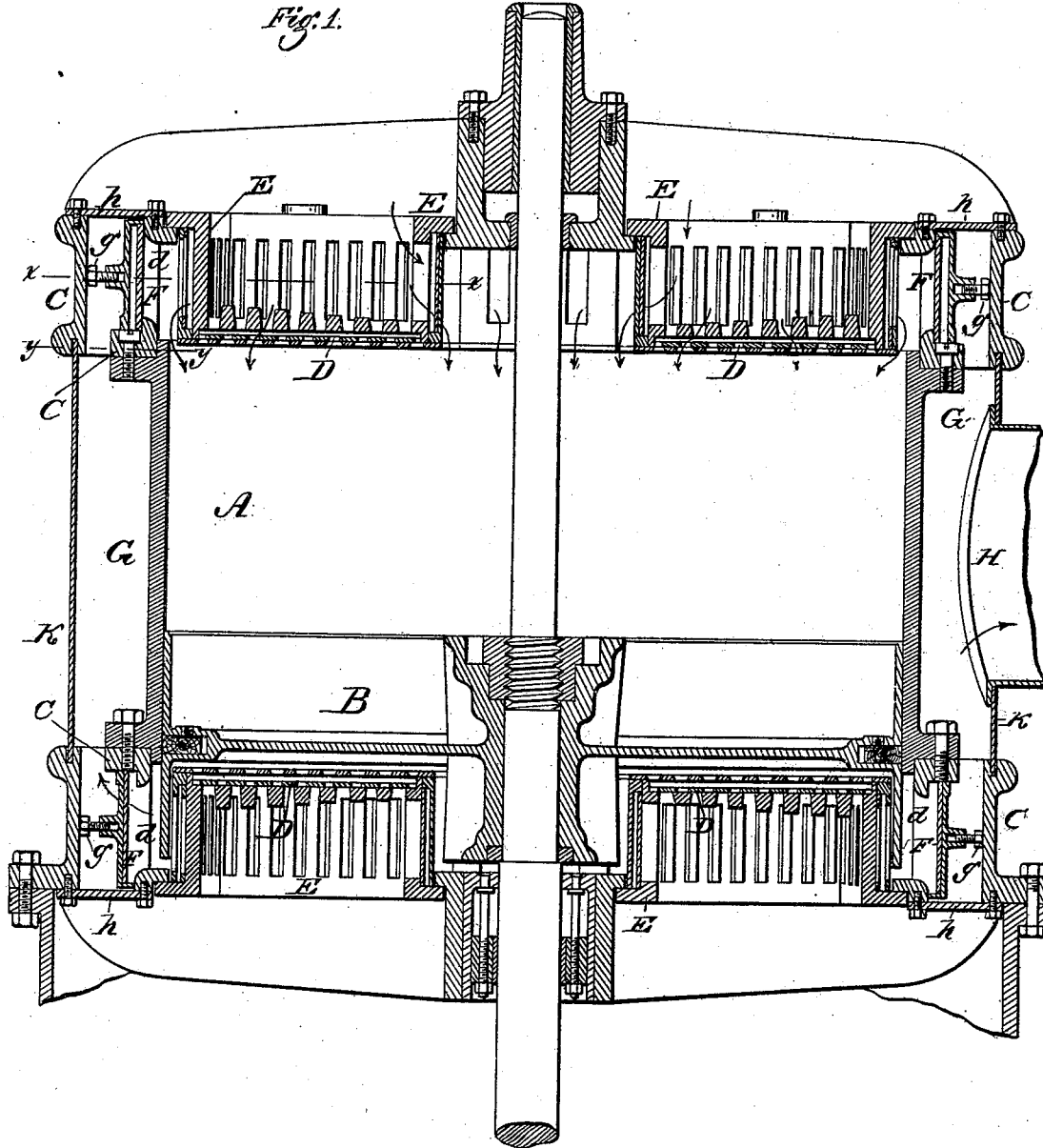

Witnesses:
Will W. Dodge.
John S. Churchill.

Inventor:
P. L. Weimer
By his Atty.
Dodge & Son

P. L. WEIMER.
BLOWING ENGINES.

No. 181,295.

Patented Aug. 22, 1876.

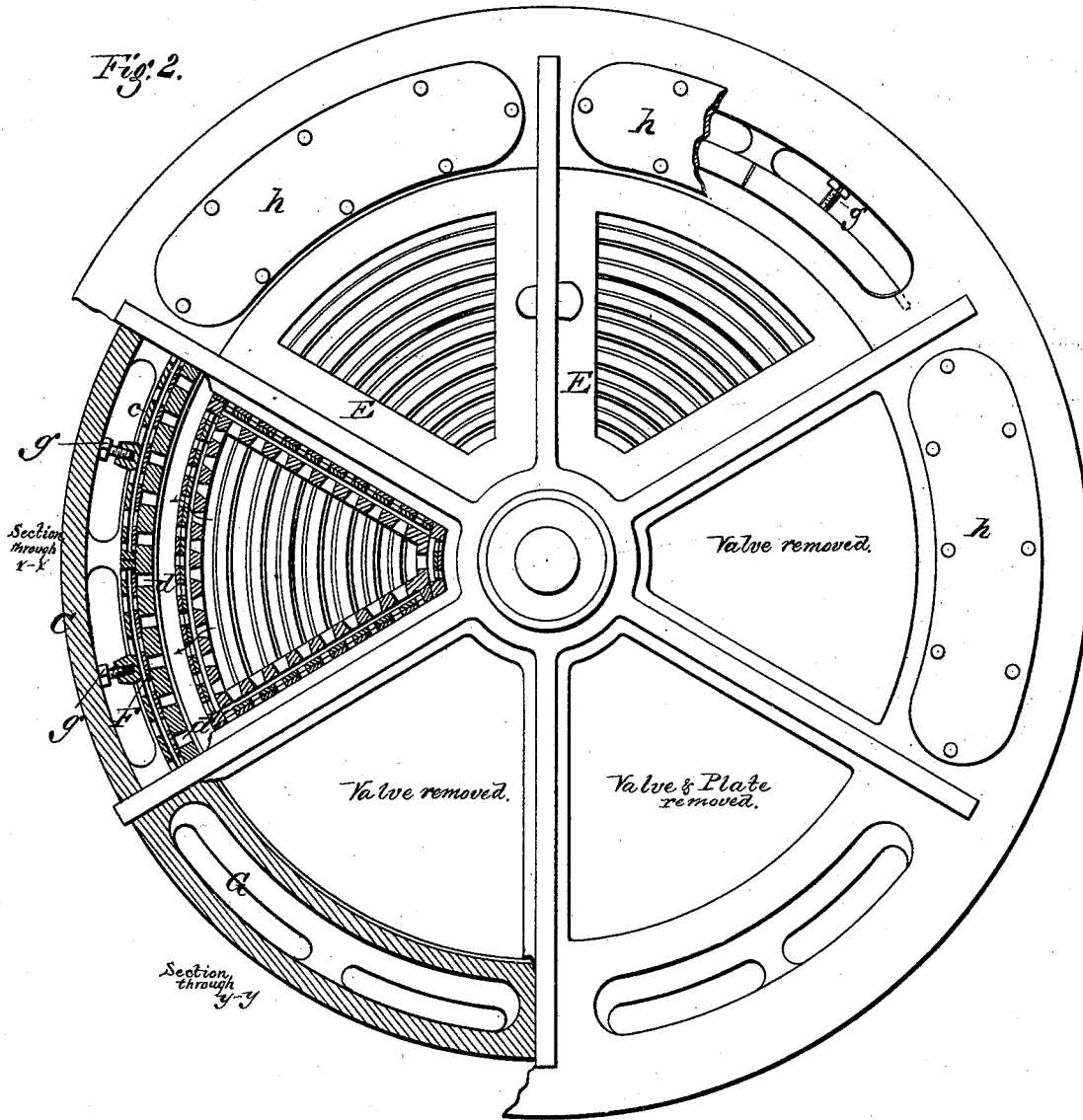

Witnesses:
 Will H. Dodge
 John S. Twitchell.

Inventor:
 P. L. Weimer
 By his attys
 Dodge & Son

P. L. WEIMER.
BLOWING ENGINES.

No. 181,295.

Patented Aug. 22, 1876.

Fig. 3.

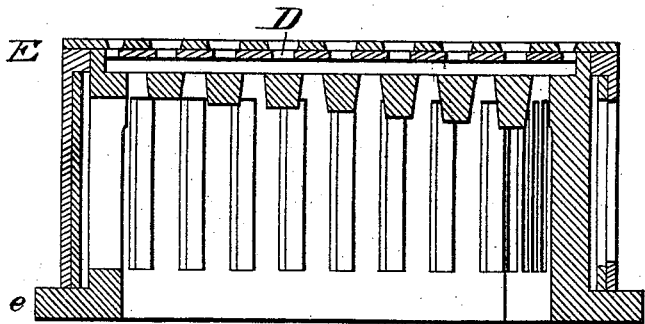
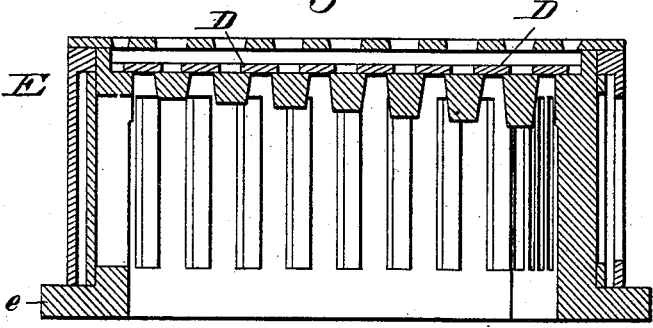

Fig. 4.



Witnesses:
Will St. Dodge,
Donn S. Twitchell,

Inventor:
P. L. Weimer
By his attys.
Dodge & Son

P. L. WEIMER.
BLOWING ENGINES.

No. 181,295.

Patented Aug. 22, 1876.

Fig. 5.

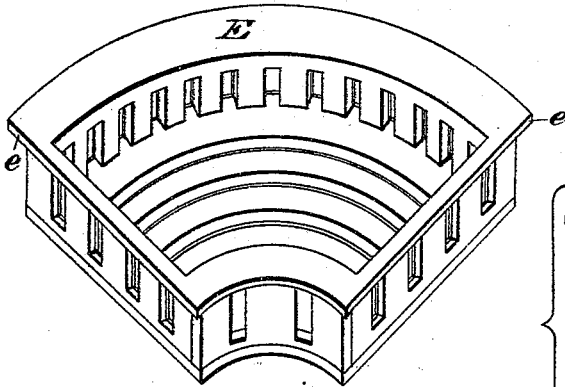

Fig. 7.

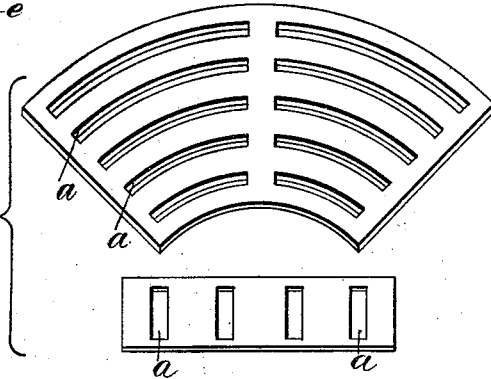

Fig. 6.

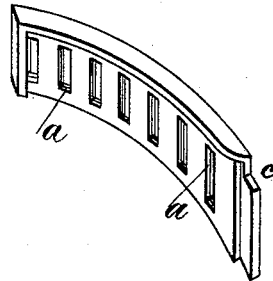

Fig. 8.

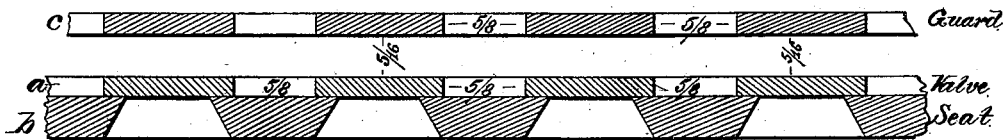
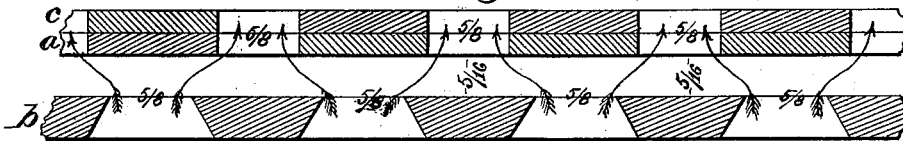

Fig. 9.



Witnesses:

Will H. Dodge
Omn S. Eitchell

Inventor:

P. L. Weimer
By his attys.
Dodge & Son

UNITED STATES PATENT OFFICE.

PETER L. WEIMER, OF LEBANON, PENNSYLVANIA.

IMPROVEMENT IN BLOWING-ENGINES.

Specification forming part of Letters Patent No. **181,295**, dated August 22, 1876; application filed June 7, 1876.

To all whom it may concern:

Be it known that I, PETER L. WEIMER, of Lebanon, in the county of Lebanon and State of Pennsylvania, have invented certain Improvements in Blowing-Engines, of which the following is a specification:

The object of my invention is to produce a reciprocating blowing-engine, which can be run at a high speed, and under a high pressure, without difficulty; and to this end the invention consists in various improvements in the construction and arrangement of the valves, the piston, and various minor details, as hereinafter described and explained.

Many attempts have hitherto been made to construct blowing-engines, which could be driven at high speeds against the high pressure of air required for furnace service; but notwithstanding the success which has been attained in other high-speed steam machinery, the attempts to produce high-speed blowers have resulted in failure, and consequently the most approved blowers of the present day are of a size, weight, and cost far exceeding other steam apparatus of equal power. In all experiments with blowing-engines three great difficulties have been encountered, viz., the impossibility of obtaining inlet and outlet valves of sufficient area to permit the free ingress and egress of the air; the impossibility of producing valves which would withstand the rapid motion and the heavy pressure of the air, and at the same time permit the air to pass freely, and the large amount of "dead space" existing in the cylinder at the end of the stroke, preventing the economical working of the engine against high pressures.

Valves of various forms have been tested, among others, flap-valves, hinged at one side, lift or check-valves, having vertical guides, and valves of different styles, operated mechanically, with a positive motion; but it was found that the first two, in order to afford a free passage for the air, required to move so far that they could not open and close with sufficient frequency, and that owing to the distance which they fell the heavy pressure of air drove them down with such violence upon their seats that they were soon destroyed, while the last or positive-motion valve could not be made to open or close with sufficient

frequency or suddenness, nor to afford the required area of opening for the inlet of the air.

It is to overcome the difficulties above enumerated that my invention is intended.

The invention consists in the use of a valve provided with parallel slits or grated like a gridiron, arranged to rise and fall between a seat and a guard-plate of like form, whereby I obtain a large area for the passage of the air, render a slight movement of the valve sufficient to open it to its full capacity, and give the valve a firm support, so that it is protected from destructive wear; in constructing seats or chests to receive the inlet-valves of less diameter than the cylinder, and extending them therein, and providing them with valves in their sides or edges as well as in the faces, whereby I compensate for the space occupied by the valve-seats, and obtain a valve area fully or nearly equal to the area of the piston, thus allowing the air to enter freely and rapidly behind the receding piston; in arranging the outlet-valves around the outside or circumference of the cylinder, and surrounding the latter by a chamber, which receives the air and conducts it to a pipe leading to the furnace or other required point, whereby a free egress of the air is permitted and the employment of a larger outlet-area allowed than when both the inlet and outlet valves are placed in the cylinder-head; and in giving the piston a wide surface-bearing, and providing it with a wooden packing to prevent leakage and reduce the friction and wear; and also in recessing the piston in such manner that at the end of each stroke it fits down over and around the valve-chests and fills practically all the space in the end of the cylinder, whereby it is caused to expel all the air, so that the engine can operate successfully and economically against a high pressure of air.

Figure 1 represents a longitudinal central section through my improved engine; Fig. 2, an end view of the same, with different portions taken in section, on the various lines of Fig. 1 thereon indicated; Fig. 3, a sectional view of one of the lower inlet-valve chests and valves, with the valves open; Fig. 4, a similar view, with the valves closed; Fig. 5,

a perspective view of one of the upper valve-chests and its valves; Fig. 6, a view of one of the outlet-valves and its guard-plate detached; Fig. 7, a view illustrating the form of the leather inlet and outlet valves, the valves being shown detached from their seats; Figs. 8 and 9, enlarged sectional views, showing more clearly the construction and operation of the valves.

A represents the engine-cylinder; B, the solid reciprocating piston, mounted in the cylinder; C C, two hollow rings, bolted to the ends of the cylinder, and serving as seats for the outlet-valves, and as supports for the seats or chests of the inlet-valves; D, the inlet-valves; E, the seats or chests in which the inlet-valves are mounted; F, the outlet-valves; G, the annular chamber, into which the air is discharged from the cylinder through the outlet-valves; and H, a pipe leading from the chamber G to the furnace or other desired point.

The construction of the valves, which constitutes the main feature of my invention, is most clearly represented in Figs. 3, 4, 5, 6, 7, 8, and 9. Each valve consists of a flat leather sheet, of any desired form, provided, as shown in Fig. 7, with parallel slits *a*, like a gridiron, and mounted in such manner as to vibrate freely between a grated seat, *b*, and a grated guard-plate, *c*. The slits or openings in the three parts are made of equal width, and the seat and guard-plate arranged parallel with each other, and at such distance apart that the valve can only move a distance equal to one-half the width of the slits. The slits in the leather valve are directly opposite the solid portion or bars of the seat, so that when the valve rests thereon it covers and closes the openings, and prevents the air from passing through. The openings or slits in the guard-plate, however, correspond to or register with those in the leather valve, so that when the valve is raised against the guard-plate, as shown in Figs. 3 and 9, the air can pass freely inward through the guard-plate, valve, and seat into the cylinder.

In practice, I find it best to make the slits or openings through which the air passes five-eighths of an inch in width, and to allow the valve to rise five-sixteenths of an inch; but it is obvious that this may be departed from, if desired.

By the use of the grated seat-valve and guard, I obtain a very large aggregate area of opening for the air to pass through, and thus permit the cylinder to fill instantly when the engine is working at its highest speed; enable the valves to open to their maximum capacity, and close again by a very slight movement, so that they can operate instantly and with great rapidity, and without the usual noisy and destructive hammering common to valves having the usual long movement, and also give the largest valve-leather support at points near each other over its entire surface, thereby protecting it from destruction by the

heavy pressure of air to which it is subjected, and by which it is driven violently back and forth.

The essential feature or characteristic of my valve is the grated leather, in connection with the corresponding grated seat, and a grated or other skeleton guard-plate, and it is obvious that the shape and size of the valve and the details of construction in other respects may be varied at will.

In constructing my engine I arrange the inlet-valves to occupy the entire end of the cylinder, and locate the outlet-valves around the outside or circumference of the cylinder, thus allowing room for valves of ample size and area. The inlet-valves D are mounted in sector-shaped chests or seats E, such as represented in Fig. 5, which are seated in openings in the cylinder-heads, as shown in Figs. 1 and 2. As shown in the drawings, the chests or seats have raised sides like a box, and valves both in their faces and in said sides. The sides are formed with outside supporting-lips *e* at their upper edges, to rest upon the cylinder-heads and sustain the chests, which are inserted through the heads into the cylinder, in the manner represented in Fig. 1, so that the valves in the side walls of the chest, as well as those in the face, admit air directly into the cylinder, as indicated by the arrows. By thus extending or sinking the valve-chests into the cylinder, and providing them with the valves in their side faces or walls, I am enabled to obtain a greatly-increased aggregate area of inlet-opening, and to compensate for the obstruction offered by the valve-seats in the faces, so that the air can enter freely and rapidly, and fill the cylinder instantly when the piston is traveling at the highest attainable speed. The outlets for the air consist of parallel slits or openings *d*, made in the rings C, which latter serve as seats for the outlet-valves F. As shown in the drawings, the rings C are made hollow, or with an annular space in the interior. The slits or openings *d* extend from the interior of the cylinder through the inner side or wall of the rings into their interior space, as shown.

The slotted-leather valves F are inserted through large openings in the ends of the rings and placed over the slits *d*, and then secured in position by placing over them, as shown in Figs. 1 and 2, slotted guard-plates of a corresponding curved form, as shown in Fig. 7. These guard-plates are held and forced up tightly in place by bolts *g* seated at one end in the plates, and bearing at their heads against the outer wall of the rings, as shown. The outlet-valves, seats, and guards are constructed and arranged to operate in precisely the same manner as the inlet-valves, the only difference being that of form, necessitated by the different locations in which they are mounted. After the outlet valves and guards are inserted, the openings in the ends of the rings C are covered and closed by plates *h*, as shown. In order to remove the

valves it is only necessary to remove the plates and loosen the bolts *g*, when the guards and valves may be taken out.

The outer walls of the rings *C* are of greater diameter than the cylinder, and have their edges provided with grooves, into which are inserted the ends of a sheet-metal drum or cylinder, *K*, of such diameter that an annular space or chamber, *G*, exists between it and cylinder *A*, as shown. The drum *K* is provided on one side with a pipe, *H*, leading to the furnace or other desired point. The air driven from the cylinder by the piston passes through the valves *F* into the chamber *G* and thence through the pipe *H*.

The piston *B* is constructed, as shown, with a very wide surface-bearing, to reduce the wear and prevent the air from leaking past it, and is provided at its middle with a circumferential groove containing a wooden packing, *h*, pressed outward by spiral springs against the face of the cylinder, the packing being prepared for use by a thorough boiling in tallow. The faces of the piston are recessed and shaped to fit down over, around, and between the valve-chests, in such manner that at the end of each stroke it drives, practically, all the air from the cylinder, so that the full benefit of the stroke is realized, and the engine caused to operate effectively and economically when pumping the air at a high pressure.

The form of the piston, with its wide rim or periphery, its transverse ribs to enter between the valve-chests, and its thin body, combines lightness and strength in a remarkable degree, rendering it easy to operate on account of its lightness, and durable on account of the large wearing-surface produced.

While I prefer to construct the engine in all respects as shown and described, it is obvious that the arrangement of various details may be varied without departing from the limits of my invention. It is also obvious that my improved valves may be used in engines of any other construction, and in pumps for moving fluids as well as in blowing-engines.

Having thus described my invention, what I claim is—

1. The combination, substantially as shown and described, of a grated valve, valve-seat, and guard-plate.

2. The combination of a grated valve-seat, a grated valve-guard, and a grated leather valve, arranged to vibrate between the seat and the guard, the slits or openings in the valve and guard being arranged to correspond or register with each other, while those in the seat are arranged to be covered or closed by the leather, substantially as shown and described.

3. In combination with the cylinder *A* and piston *B*, the valve-chests or seats *E*, extending into the cylinder, and provided with inlet-valves both in their faces and walls, substantially as shown and described.

4. The cylinder *A*, having the inlet-valves *D* located in its ends, and the series of outlet-valves *F* located around its periphery or circumference, as and for the purposes described.

5. In combination with the cylinder *A*, provided with the series of circumferential outlet-valves *F*, the annular surrounding chamber *G*, provided with a discharge-pipe.

6. The combination of the cylinder *A*, the hollow rings *C*, provided with the air-outlets or throats *d*, the valves *F*, and the curved valve-guards, applied within the ring, as shown.

7. In combination with the cylinder *A* and the valve-chests *I*, extending therein, the piston *B*, recessed and adapted to fit down over, around, and between the chests, as shown, and for the purpose described.

8. The piston *B*, constructed with the wide surface-bearing and the recessed faces, and provided with the circumferential wooden packing, substantially as shown.

PETER L. WEIMER.

Witnesses:

TOBIAS REINOEHL,
W. G. SANDS.