

S. R. HIBBARD.

TOY CANNON.

No. 181,341.

Patented Aug. 22, 1876.

Fig. 1

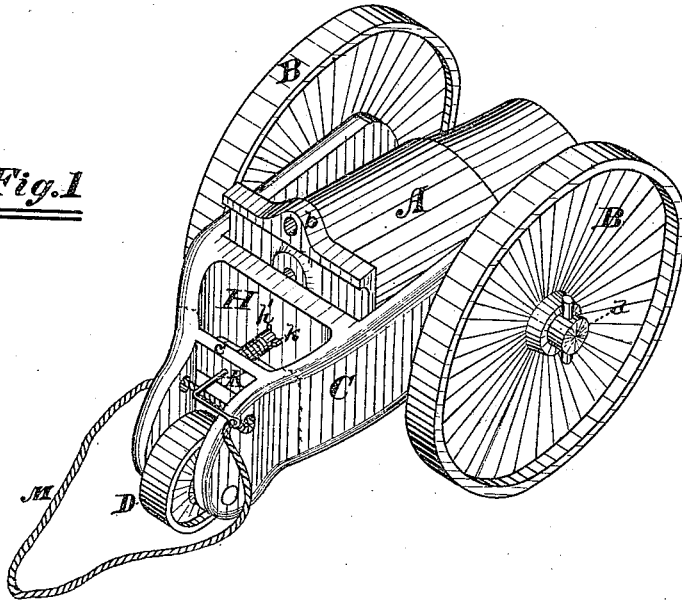

Fig. 2

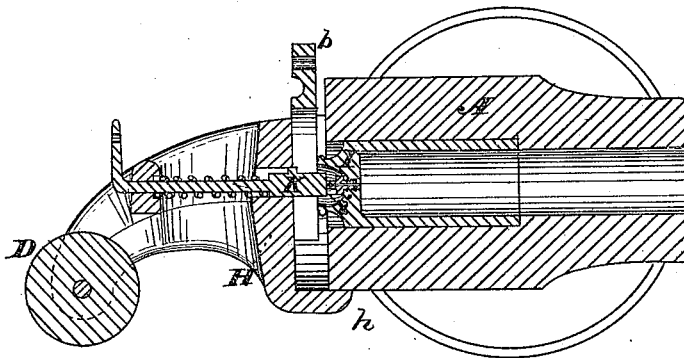
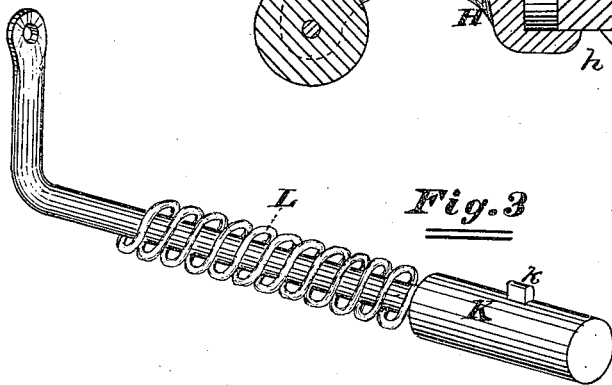

Fig. 3



Attest

W. S. Baker

L. M. Harnd.

Inventor

Scott R. Hibbard

By Columbus Thacker

Attorneys

S. R. HIBBARD.

TOY CANNON.

No. 181,341.

Patented Aug. 22, 1876.

Fig. 4

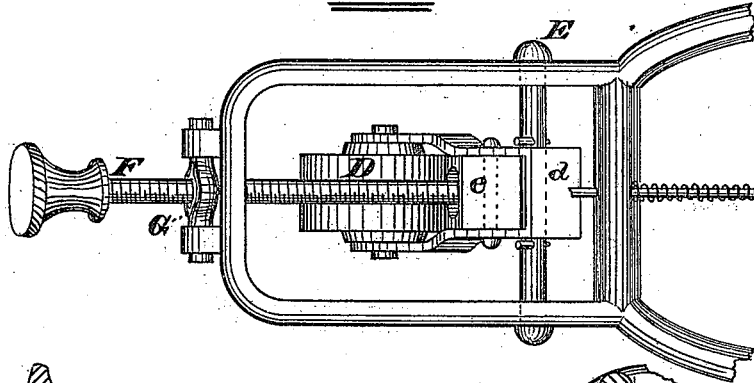

Fig. 5

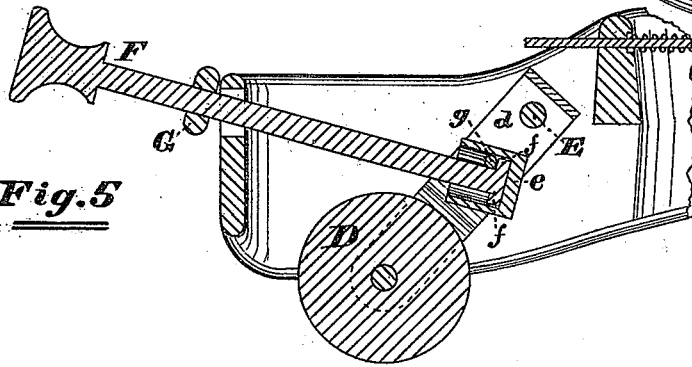
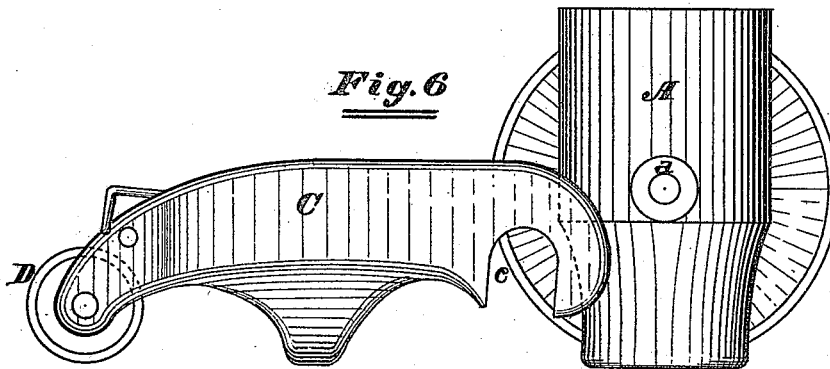

Fig. 6



Attest
W. S. Baker,
L. M. Harris

Inventor
Scott R. Hibbard
By *Charles H. ...*
Attorneys

UNITED STATES PATENT OFFICE.

SCOTT R. HIBBARD, OF CHICAGO, ILLINOIS.

IMPROVEMENT IN TOY CANNONS.

Specification forming part of Letters Patent No. 181,341, dated August 22, 1876; application filed May 15, 1876.

To all whom it may concern:

Be it known that I, SCOTT R. HIBBARD, of Chicago, in the county of Cook and State of Illinois, have invented a new and useful Improvement in Toy Cannons, which is fully described in the following specification, reference being had to the accompanying drawings, in which—

Figure 1 represents a perspective view of the cannon; Fig. 2, a longitudinal sectional view taken on the line *x x*, Fig. 1; Fig. 3, a detail view of the firing-pin; Fig. 4, a plan view of the elevating apparatus; Fig. 5, a sectional view of Fig. 4; and Fig. 6, a side elevation, with one wheel removed and the frame detached.

My invention relates to a toy cannon for use in firing salutes, &c.

The invention consists in making the trunnions the axles for the supporting-wheels; also, in the peculiar construction of the trail-carriage frame, so that it may be readily attached and detached from the cannon; also, in the construction of the firing-pin; and also in devices for training the cannon by adjusting the trail-carriage.

In the drawings, A represents the cannon, which is cast with elongated trunnions *a*. These trunnions are made of such size and length as to serve the purpose of axles for the supporting-wheels B, which are placed thereon and secured in any ordinary manner. The trail-carriage C is constructed with two arms or branches at its forward end, in the extreme front ends of which are recesses *c*, of suitable size to receive the trunnions *a*. The arms of the frame extend forward, one on each side of the gun, as seen in Fig. 1 of the drawings, and engage with the trunnions by claspings them inside of the wheels, the trunnions being received in the recesses *c*. By this construction the trail-frame can be detached from the cannon with the greatest ease.

At the rear end of the trail-frame is a small supporting-wheel, D, which, as shown in Figs. 1 and 2, performs no other function than that of a supporting-wheel; but this wheel may, if desired, be mounted in a frame, *d*, which is supported loosely upon the cross-pivot E at the rear end of the trail-frame. In the frame

d is also pivoted a swivel-block, *e*. A screw-shaft, F, passes through a nut, G, pivoted to the rear end of the trail-frame. The shaft extends forward through the end of the frame, and is provided with a button, *f*, at its forward end, which passes in front of a pin, *g*, in the recess of the swivel-block *e*. It will be seen from this construction that, by setting the shaft back and forth by turning it in the nut G, the frame *d* will be swung backward and forward, thereby raising or lowering the rear end of the trail-frame. At the lower edge of the bridge H a circular flange, *h*, projects forward a slight distance, so as to form a rest for the breech, as seen in Fig. 2 of the drawings. The adjustment of the rear end of the trail-frame above described will consequently serve to adjust or train the cannon.

A metallic cartridge, I, is to be used with this cannon, in which is placed the charge of powder; and the bore of the gun, which is a breech-loader, is somewhat larger at the breech than at the muzzle, for the purpose of receiving the cartridge, as shown in Fig. 2 of the drawings. The charge is fired by a firing-pin, K, striking against the nipple *i* of the cartridge. The firing-pin K is supported in the bridge H and cross-brace *c'*, just back of the bridge, and is provided with a lug, *k*, near its forward end. A groove, *h'*, is cut in the bridge H, to permit the pin K to slide forward in the bridge when it is turned, so that the lug *k* can pass into the groove *h'*. When, however, the pin is drawn back until the lug *k* is withdrawn from this groove and the pin turned, it is prevented from sliding forward by the lug *k* resting against the bridge. The rear end of the pin K is bent so as to form a crank-arm, by means of which the pin is turned as desired. The front end of the pin is somewhat larger than the other portion, and a coiled spring, L, is placed around the smaller part of the pin, and held in place by the shoulder of the pin itself and the brace *c'*, through which the rear end of the pin passes.

When the firing-pin is drawn back in the position shown in Fig. 1 of the drawings, the spring L will be compressed, so that, as soon as the pin is turned up sufficiently to permit the lug *k* to enter the slot *h'*, the spring will

drive the pin forward quickly against the nipple of the cartridge, and thereby discharge the gun.

Back of the cartridge I, and between it and the bridge H, is placed a wedge-block, *b*, which holds the cartridge in place, and is slotted to permit the passage of the firing-pin. The extreme end of the bent portion of the firing-pin has a hole through it, through which the lanyard M is run, and afterward passed through holes in the rear end of the trail-frame, as seen in Fig. 1 of the drawings. This arrangement is for the purpose of using the lanyard for hauling the cannon. A knot is tied in the lanyard between the firing-pin and the trail-frame, so that, when a pull backward is made on the lanyard, the knot in the rope, coming against the firing-pin, will turn it up in the position shown in Fig. 2, and the gun will be discharged.

The cannon is made of such length that when turned over and stood up in a vertical position upon its muzzle end, as shown in Fig. 6 of the drawings, it will just raise the wheels from the ground, so that they can be readily removed for any purpose whatever. The gun may be thrown into this position for loading, if desired, and is easily brought back into a horizontal position by pulling back on the trail-frame.

I have described and shown my invention applied to a toy cannon; but it is evident that at least some features thereof are applicable to the construction of ordnance for military purposes.

Having thus described my invention, what

I claim as new, and desire to secure by Letters Patent, is—

1. The cannon A, constructed with elongated trunnions *a*, which are made in one piece with the gun, and also serve as axles for the supporting-wheels, substantially as described.

2. The combination of a cannon, A, and a detachable trail-frame, substantially as described.

3. The trail-frame C, constructed with open recesses *c* in its forward ends for the purpose of hooking upon the trunnions *a*, substantially as described.

4. The flange *h* on the bridge H of the trail-frame, to form a rest or support for the rear end of the cannon, substantially as described.

5. The combination of the bridge H, provided with a hole for the firing-pin, and a groove, *h'*, and the spring firing-pin K, having a lug, *k*, on its forward end, substantially as and for the purpose set forth.

6. The combination of the spring firing-pin K, having its rear end bent, as specified, the trail-frame C, and the rope M, all arranged as described, so that the rope serves the double purpose of a lanyard and hauling-rope, substantially as set forth.

7. The combination of the wheel-frame *d*, pivoted to the trail-frame, swivel-block *e*, screw-shaft F, and nut G, substantially as and for the purpose set forth.

SCOTT R. HIBBARD.

Witnesses:

L. A. BUNTING,
W. S. BAKER.