

J. L. MUELLER.
 VEHICLE DRAFT-APPLIANCES.

No. 181,358.

Patented Aug. 22, 1876.

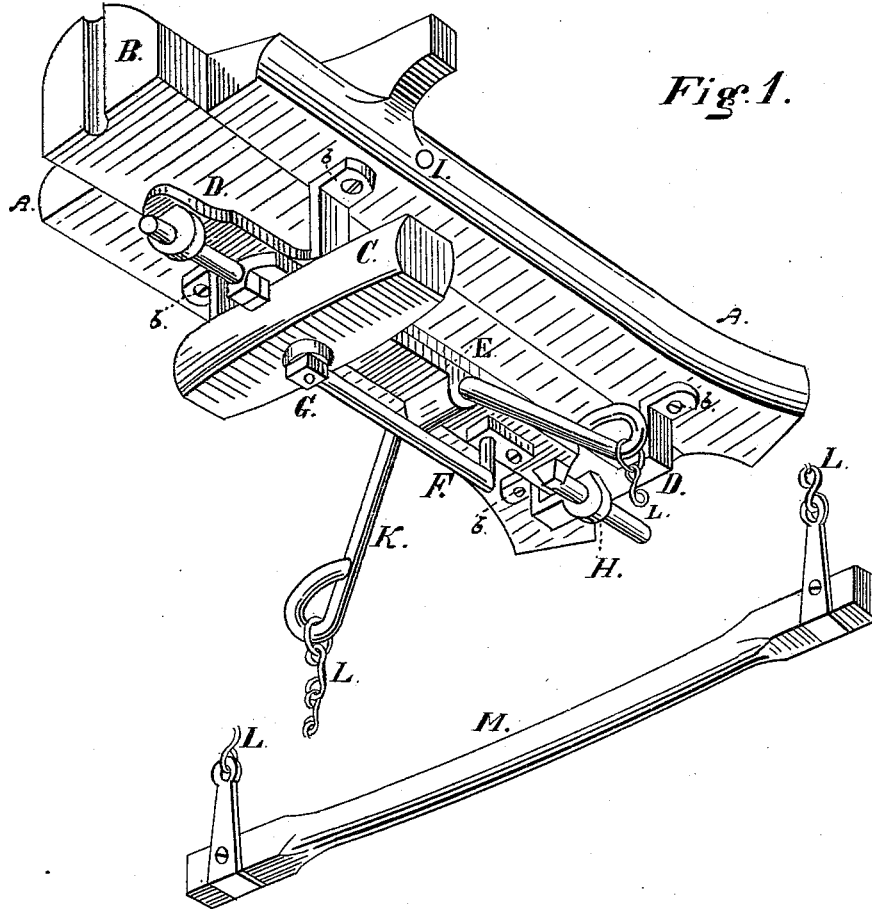

Fig. 1.

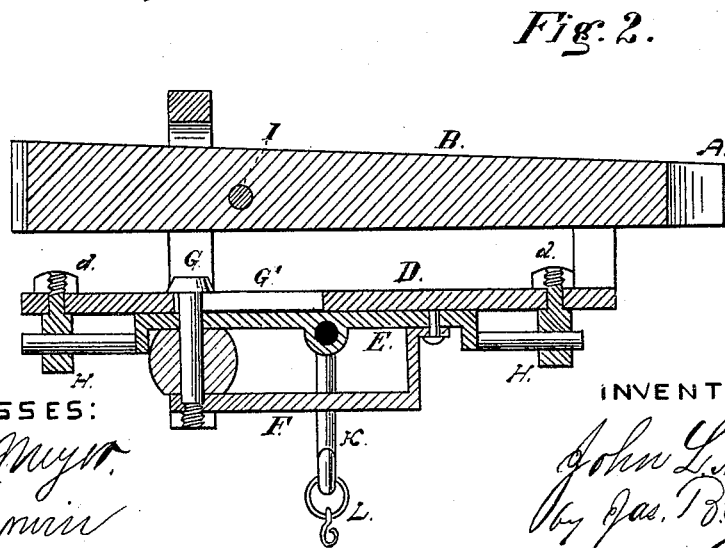

Fig. 2.

WITNESSES:

G. H. Myer
O. R. Emwin

INVENTOR:

John L. Mueller
 By *Gas. P. Emwin*
att.

UNITED STATES PATENT OFFICE.

JOHN L. MUELLER, OF MILWAUKEE, WISCONSIN, ASSIGNOR TO HIMSELF
AND C. H. MEYER, OF SAME PLACE.

IMPROVEMENT IN VEHICLE DRAFT APPLIANCES.

Specification forming part of Letters Patent No. **181,358**, dated August 22, 1876; application filed April 11, 1876.

To all whom it may concern:

Be it known that I, JOHN L. MUELLER, of the city of Milwaukee, in the county of Milwaukee and State of Wisconsin, have invented certain new and useful Improvements in Wagon Draft Appliances; and I do hereby declare that the following is a full, clear, and exact description thereof, which will enable others skilled in the art to which it appertains to make and use the same, reference being had to the accompanying drawings, and to the letters of reference marked thereon, which form a part of this specification.

My invention relates to improvements in the mode of attaching the double-tree to light carriages and platform spring-wagons, whereby the carriage-tongue is relieved of the weight of the double-tree and draft appliances, and is at liberty to move freely upward and downward without disturbing the natural line of the draft, which is brought more directly upon the axle-tree of the carriage; and it consists in a device which is attached to the under side of the hounds beneath the tongue, and which connects the double-tree with the front axle-tree of the carriage.

Figure 1 of the accompanying drawings is a perspective view of my invention. Fig. 2 is a view of a transverse section of the same.

Similar letters of reference indicate corresponding parts.

B represents the tongue of the carriage, which is attached to the hounds A with the bolt I. D is a substantial iron bracket, which is securely attached to the hounds A with bolts *bbbb*. HH are eyebolts, which are attached to the bracket D by nuts or burrs *dd*. E is the draw-bar, to which the evener C of the double-tree is attached by the bolt G and bracket F, in the ordinary manner. The draw-bar E is held in its position against the under side of the bracket D by the eyebolts H H, through which the ends of the draw-bar

E pass. The draw-bar E has a movement backward and forward as the carriage is jostled backward and forward by obstructions, with which the front wheels come in contact, or by sudden starting and stopping of the team.

There is a slot, G', in the bracket, through which the bolt G moves as the draw-bar E moves forward and backward. K is a heavy iron rod, which passes through a hole in the draw-bar E, or is otherwise securely attached to it. Each end of the rod K is connected with the axle-tree of the wagon M by a series of hooks or links, L L.

It is obvious that with this device the weight of the double-tree does not come upon the necks of the horses, as is the case when attached to the tongue in the ordinary manner, but is sustained by the hounds; also, that the oscillation of the axle-tree which occurs when the wheels are passing over a rough road are not transmitted to the tongue, but simply act upon the draw-bar E, causing it to move forward or backward, as above described; also, that the draft is brought more directly upon the axle-tree of the wagon.

I claim as my invention—

1. The combination of the hounds A A, bracket D, and draw-bar E, operating as described, to relieve the tongue from all strain, as set forth.

2. The combination of the hounds A A, bracket D, draw-bar E, rod K, links L, and axle-tree M, all operating to relieve the tongue from strain, as set forth.

In testimony that I claim the foregoing as my own I affix my signature in presence of two witnesses.

JOHN L. MUELLER.

Witnesses:

P. H. MEYER,
K. SHAWVAN.