

J. M. AYER.
REFRIGERATING CAR.

No. 181,391.

Patented Aug. 22, 1876.

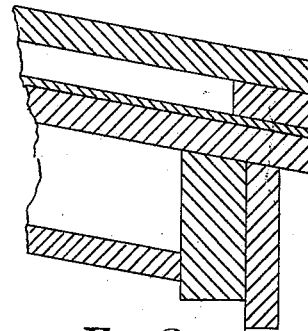
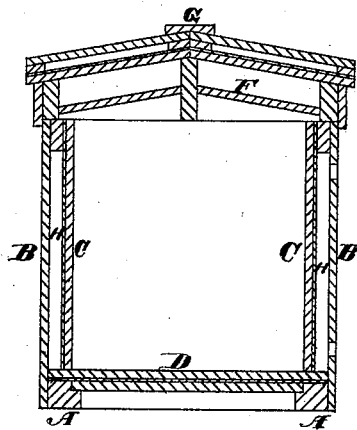
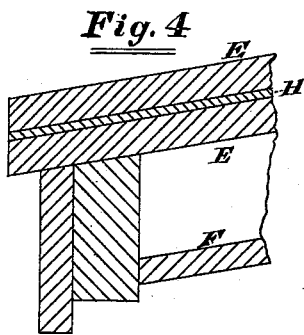
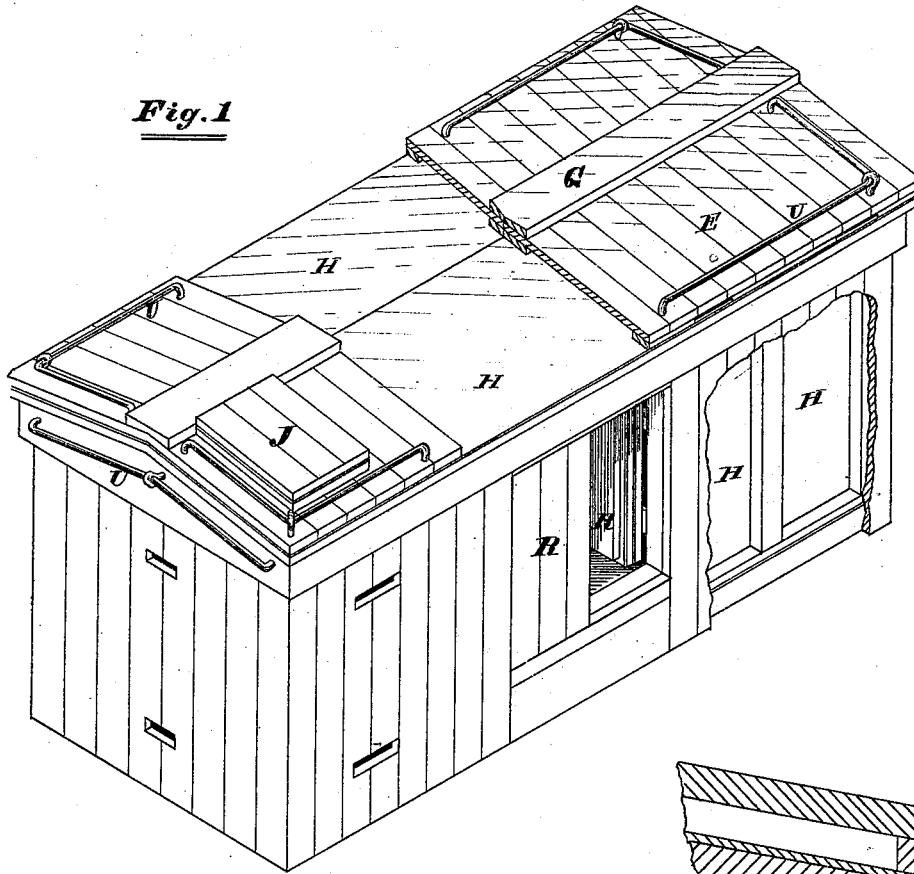

Attest
W. S. Baker
L. A. Bunting

Inventor
John M. Ayer
Coburn & Thacher
 Attorneys

J. M. AYER.

REFRIGERATING CAR.

No. 181,391.

Patented Aug. 22, 1876.

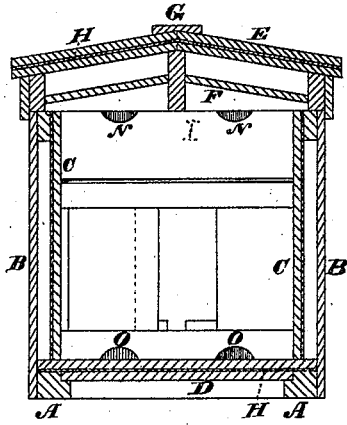

Fig. 5

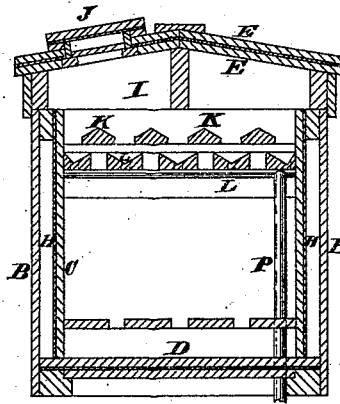

Fig. 6

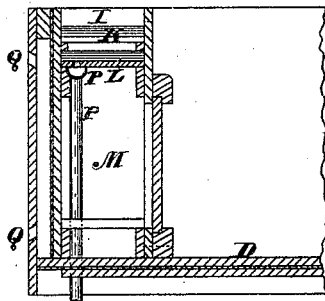

Fig. 8

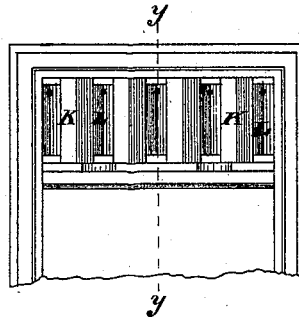

Fig. 7

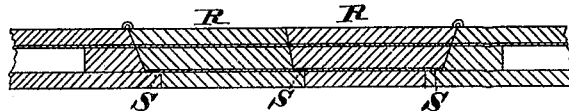

Fig. 9

Attest
W. S. Baker
L. A. Bunting

Inventor
John M. Ayer
 By *Coburn T. Thacher*
 Attorneys.

UNITED STATES PATENT OFFICE.

JOHN M. AYER, OF CHICAGO, ILLINOIS.

IMPROVEMENT IN REFRIGERATING-CARS.

Specification forming part of Letters Patent No. 181,391, dated August 22, 1876; application filed May 27, 1876.

To all whom it may concern:

Be it known that I, JOHN M. AYER, of Chicago, in the county of Cook and State of Illinois, have invented a new and useful Improvement in Refrigerator-Cars, which is fully described in the following specification, reference being had to the accompanying drawings, in which—

Figure 1 is a perspective view of the car with certain portions cut away. Fig. 2 is a transverse sectional view through the car; Figs. 3 and 4, enlarged detail views, showing two constructions of the roof; Fig. 5, a transverse sectional view, showing the interior of the car. Fig. 6 is a transverse sectional view through the refrigerator. Fig. 7 is a plan view of the refrigerator with the roof of the car removed. Fig. 8 is a vertical section taken at the line *y y*, Fig. 7. Fig. 9 is a horizontal section of the car-door, and a detached portion of the side of the car to which the doors are attached.

My invention relates more particularly to what are termed "refrigerator railway-cars," used for the purpose of preserving articles by keeping them cool while being transported to a remote market.

My invention relates to mechanism in the construction of the car, and can be applied to stationary refrigerators and rooms for preserving perishable materials, as well as movable apartments, like railway-cars and ships.

My invention consists in the structure of the roof of the car with india-rubber sheathing and board lining and two inclosed air-spaces.

A in the accompanying drawings represents the frame of a railway-car; B, the outside boards, which are tongued and grooved or otherwise closely fitted together. C are the inside or lining boards of the car. D is a double floor. E are the roof-boards, which are made double, and F is an inside lining of boards to the roof, which forms an additional air-space. G is the ordinary race-board on the top of the car. H represents the layer of india-rubber cloth or rubber packing, which makes a lining to the wall, and also between the roof-boards and the floor-boards, as shown in the drawings.

I do not limit myself, however, to placing the india-rubber lining in just the position here shown, it being the purpose to place it in

such positions in the roof, floor, and walls as to form a lining or coating thereto, and make the refrigerator impervious to heat.

I have an ice-apartment, I, at each end of the car, which is reached by a man-hole, J, through the roof of the car. K are beveled strips, upon which the ice is placed, and L are concave strips placed beneath the beveled strips K, that support the ice in such a manner as to catch the drip as the ice melts, and at the same time admit of the circulation of the air through the compartment, as hereafter specified.

P is a pipe for conducting the water from the refrigerator. There may be placed in this pipe a valve, which will admit of the water passing out, and prevent the admission of air. M is a small compartment under the ice, in which such articles are placed as are desirable to keep particularly cool. N N are air-passages from the main cooling-apartment of the refrigerator into the ice-apartment, and O O are air-passages from the compartment M into the main cooling-apartment. The air passes from the main cooling-apartment into the ice-apartment, where it comes in contact with the ice, passes down between the beveled strips K and convex strips L into the apartment M, and out into the main cooling-apartment. Q Q are openings through the outer case B of the refrigerator-car, opening into the space in the wall at such places as will produce ventilation of air through the space. I place these openings so as to ventilate any air-space I may make either in the wall, roof, or floor of the refrigerator. The doors R of the car are made solid, of three thicknesses of boards, with the sheet-rubber or lining of rubber packing between them, and so constructed as to make bevel-joints and a rubber packing in each of the joints, as shown at S.

I make a refrigerator-car which is nearly as light as an ordinary freight-car, is so constructed as to require but a small quantity of ice, has nearly as much space for freight as an ordinary freight-car, has free circulation of air from its cooling-apartment through the ice-apartment, has its walls ventilated in such manner as to gather no impurities or odors, and is almost impervious to heat and other influences from the external atmosphere.

I construct the roof of the car either with an air-space, as shown at T in Fig. 3, or without it, as shown at Fig. 4.

I place a railing, U, around the top of the car, under the roof, as shown in Fig. 1, for the brakeman to catch hold of and save himself from falling from the car in case of accident when the car is slippery.

I do not claim, broadly, the use of india-rubber sheathing with single air-space and board lining, because that is shown in my patent dated July 18, 1876, No. 180,088.

Having thus fully described the construction and operation of my invention, what I claim as new, and desire to secure by Letters Patent, is—

1. In a refrigerator-car, the roof-boards E E, with an air-space between them and over the india-rubber sheathing H, combined with the inside board lining F, to form an additional air-chamber above said lining:

2. In a refrigerator-car, the roof-boards E E, india-rubber sheathing H, and inside lining-board F, inclosing two air-spaces, as shown, combined with the hollow side walls B C and india-rubber sheathing H, as set forth.

JOHN M. AYER.

Witnesses:

L. A. BUNTING,
L. M. HARRIS.