

J. D. McEACHERN.

ATTACHMENTS TO VENEER-CUTTING MACHINES.

No. 181,461.

Patented Aug. 22, 1876.

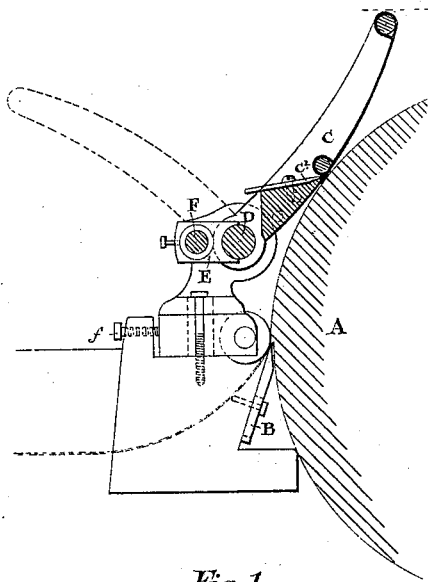

Fig. 1.

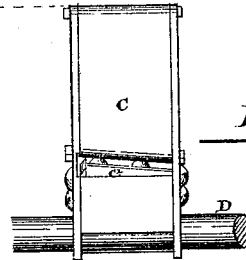

Fig. 3.

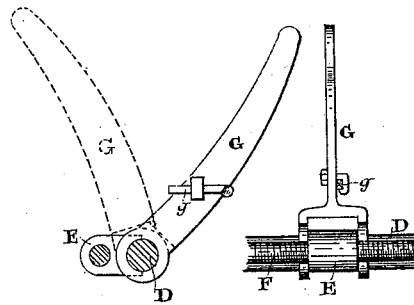

Fig. 4.

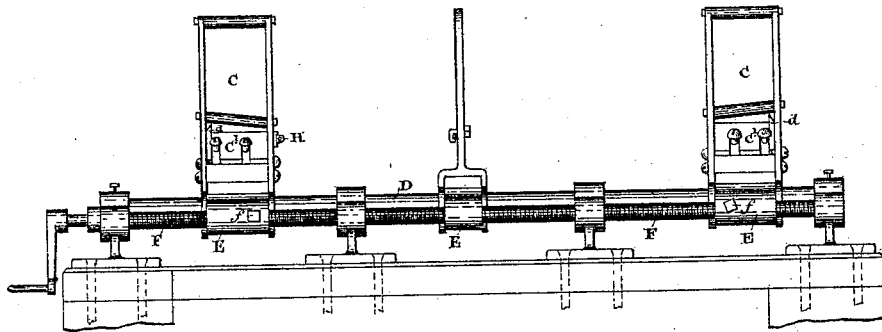

Fig. 2.

Witnesses.

Leas Tomlinson

Robt. Kilgour

Inventor.

John D. McEachern

by Kidout, Bird & Co.

Attys

UNITED STATES PATENT OFFICE.

JOHN D. McEACHERN, OF HARRISTON, ASSIGNOR TO SAMUEL WALLACE,
OF SEAFORTH, ONTARIO, CANADA.

IMPROVEMENT IN ATTACHMENTS TO VENEER-CUTTING MACHINES.

Specification forming part of Letters Patent No. **181,461**, dated August 22, 1876; application filed
November 23, 1875.

To all whom it may concern:

Be it known that I, JOHN D. McEACHERN, of the village of Harriston, in the county of Wellington and Province of Ontario, Canada, manufacturer, have invented certain new and useful Improvements in Attachments to Veneer-Cutting Machines, of which the following is a specification:

My invention relates to certain improvements in a machine for manufacturing veneers for barrels, cheese-boxes, band-boxes, &c.; and consists in an attachment for either beveling or rounding off the edges of the veneer as the sheets are being cut from the log, as and for the purpose hereafter specified.

Figure 1 is a section, showing the machine in operation. Fig. 2 is a cross view of improvement. Fig. 3 is a detail of cutters for beveling. Fig. 4 is a detail of cutters for rounding off.

A is the log from which the veneer is being cut. The log is made to revolve on the center of the lathe, and the knife B, which is the full length of the log, is so set that it shaves from the log a strip of veneer the length of the circumference of the log.

To this portion of the machine I lay no claim; but for the purpose of beveling or otherwise finishing the edges of these sheets as they are thus produced, my invention immediately relates. C C are knife-frames, attached and worked as hereafter specified. Within each of these frames is a knife, C', set so as to cut at a bevel, and a knife, d, for cutting off the ragged edge. The frames C C are pivoted upon a rod, D, and are held in position by the blocks E E. Within the blocks E E I adjust cylindrical nuts e e, which fit the screw F, but are loose within the said blocks, except when pinched by the set-screws f f, which action connects each block to its respective nut, and they then move with them as the screw F is turned.

By this arrangement the distance between

the two frames C C may be altered at will, or they can be moved together upon the rod D without their relative position to each other being affected. In operation, these knives C' are set so as to bevel off each end of the log A immediately before the veneer is cut therefrom.

Some boxes are made with only one edge beveled, the other being rounded off. For this purpose the knife-frame G is intended, the knife g being made the required shape. When the rounding-off knife is being used one of the frames C is thrown back, as shown by dotted lines in Fig. 1, in which position the frame G is put when the two others are in operation.

In turning down a log into veneers it often happens that there are places in the log defective, making it impossible to get a piece of veneer the full length. In this event the sheet of veneer is divided into two by throwing forward the knife g.

H is a pencil-holder, placed upon the inside of one of the knife-frames C, for the purpose of marking the veneer, so that all the barrels made from the pieces of veneer thus marked are the same size, provided the frames C C or frames C and G are maintained in the same relative position to each other, and that the opposite edge of the veneer be bent to and fastened at the pencil-mark referred to.

What I claim as my invention is—

The beveling-knives C' C' and cutting-off knife d, held within the frames C C, pivoted upon the rod D, in combination with blocks E E and screw F, arranged and operated substantially as described, and for the purpose specified.

Harriston, Ontario, November 10, 1875.

J. D. McEACHERN.

Signed in the presence of—

SAML. ROBERTSON,
TH. V. ROBINSON.