

C. E. SAWYER.
EYELETING MACHINE.

No. 181,540.

Patented Aug. 29, 1876.

Fig. 1.

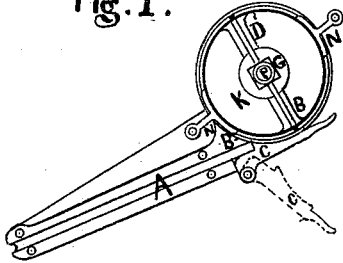

Fig. 4.

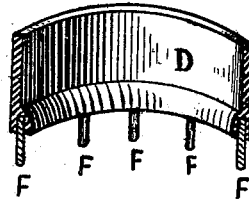

Fig. 2.

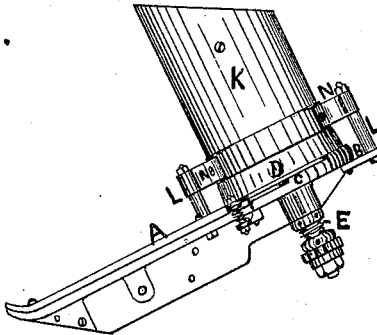
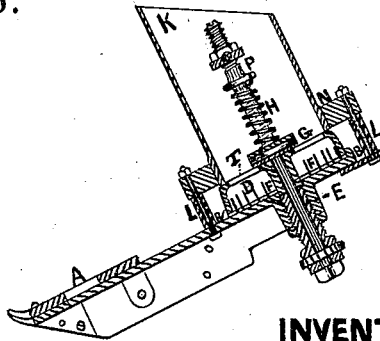

Fig. 3.



WITNESSES.

H. S. Talbot
Edward Edmunds

INVENTOR.

Charles E. Sawyer
Per Sylvanus Walker
Atty

UNITED STATES PATENT OFFICE.

CHARLES E. SAWYER, OF BOSTON, MASSACHUSETTS.

IMPROVEMENT IN EYELETING-MACHINES.

Specification forming part of Letters Patent No. 181,540, dated August 29, 1876; application filed July 26, 1875.

To all whom it may concern:

Be it known that I, CHAS. E. SAWYER, of Boston, in the county of Suffolk and State of Massachusetts, have invented certain new and useful Improvements in Eyeletting-Machines, of which the following is a specification:

The object of my invention is to increase the speed and working capacity of the machine, by insuring a constant supply of eyelets to the chute or race at all times without stopping the machine; and it consists, first, in the combination of a rotary feed-cylinder and frictional device with an elongated hopper, as hereinafter more fully set forth; secondly, in the construction of a rotative feed-cylinder, provided with flexible or elastic rubber fingers, secured around its lower edge at intervals, and projecting downward from the same, and operating within the eyelet-box at the bottom of the same, so as to continually present eyelets to be received into the opening through the side of the same connecting with the chute or race; thirdly, in the construction of an adjustable movable guard, connected at the upper end of the chute or race, so as to prevent the escape of perfect eyelets when the machine is running, yet allow of such guard being swung or pushed from the opening at the top of the chute or race when it becomes clogged by imperfect eyelets entering the same, and allow of their removal without stopping the machine; fourthly, in the construction of a friction-disk, placed within the hopper above the eyelet-box, adjusted and operated with a spiral torsion-spring connected to the said disk, and an adjustable bearing, and surrounding a vertical driving-shaft, so as to be coiled and recoil by the friction-disk on the top of the rotative feeder, so as to impart more or less of an oscillating motion to the same as it rotates.

Figure 1 is a side elevation of a hopper, chute, and box of an eyeletting-machine constructed according to my invention. Fig. 2 is a vertical section through the same. Fig. 3 is a section view of the rotative feeder removed, as constructed with the rubber fingers.

A is the chute or race, of usual construction at its upper end, near the eyelet-box. B is an arm, to which is pivoted a guard, C,

which may be swung around, or turned out from, the eyelet-box B, to which it closely fits at or over the aperture in the same, where it connects with the chute or race A, so as to allow free access at this point, to remove imperfect eyelets which clog the chute or race. When such have been removed a suitable spring returns the guard to its former position. This guard C is adjustable, so as to suit the different length of eyelets being used, and it may be slid or moved in any desired manner, to allow access in removing eyelets with a piece of wire or otherwise.

D is a rotative cylindrical feeder, connected by a cross-bar, T, on its top to the upright driving-shaft E, said shaft being journaled in the bottom of the eyelet-box B, and having a bearing, P, at its top, so as to insure the true rotation of the rotative feed-cylinder D, as such is very essential to the perfect working of the machine when run at a high rate of speed.

F F F are flexible rubber fingers or stirrers, inserted at intervals in the lower edge of the rotative feed-cylinder D, which keep the eyelets in constant motion, pushing out at the aperture those that are right side up, and removing the others, so as to keep up a continuous supply in the race or chute A when the machine is running at a much higher rate of speed than those heretofore constructed now in use. These flexible rubber fingers F I find, after many experiments, are very peculiarly adapted for the purpose of feeding the eyelets to the chute or race rapidly, on account of their elastic or flexible nature. When made of pure soft vulcanized rubber, their size may be sufficient to prevent more than a single eyelet from slipping upon any one of them at a time; whereas, if bristles were employed, as heretofore, a large number would slip upon the bristles, so as to entirely clog up the same and necessitate their removal, which would require the stopping of the machine.

In order to impart the desired oscillating or rotative motion to the feed-cylinder D, a friction-disk, G, is connected by a spiral torsion-spring, H, coiled around the upright driving-shaft E, and connected with its top bearing P. This disk G is located above the eyelet-box B and rotative feed-cylinder D, and within the

elongated hopper K, so as to be free of the oil used on the journal-bearing of the shaft E in the bottom of the eyelet-box B, which is liable to run down upon and destroy the friction when located below the bottom of the eyelet-box, as heretofore, the spiral coiled spring H being coiled or wound up on the shaft E by the action of the feed-cylinder upon the friction-disk as it is revolved by the pawl and ratchet, and recoils when the pawl slides back over the ratchet, the friction thus giving the degree of oscillation desired in the feed-cylinder D.

P is an adjustable bearing, which serves also to adjust the amount of friction on the rotative feed-cylinder D, by screwing this adjustable bearing P up or down, so as to depress or elongate the spiral coiled spring H, causing it to bear more or less upon the friction-disk G, thereby regulating the friction at will. This spiral coiled spring H has one end connected to the friction-disk G, and the other end to the adjustable bearing P, which bearing also serves to keep the upper end of the shaft E in true position. The elongated hopper K is supported at an angle by short posts L, which have clamps N, as shown, to secure it in position. If desired, this hopper K may connect with, or be an extension of the eyelet-box B upward, so as to surround and inclose the rotative feed-cylinder D; or the rotative feed-cylinder D may be extended upward sufficient to form the hopper K, being supported by standards with a cross-bar above the top of the same to receive the adjustable bearing, as before, and thus accomplish the same results. By means of this elongated hopper K, a large amount of running time is saved in supplying the machine with eyelets, as the

same may be poured into the hopper at intervals, as required, without stopping the machine, the hopper K communicating with the feed-cylinder D, which has openings on its top, so as to permit the eyelets to be received through the same into the eyelet-box B, which is open on top, instead of being closed with a cover or hinged lid, as heretofore, thus necessitating the stopping of the machine often to refill the eyelet-box with eyelets.

By means of my said improvements I am enabled to increase the working capacity of an eyeleting-machine more than fourfold, when compared with any first-class machine in use.

Having thus described my invention, what I claim is—

1. In combination with the chute or race A of an eyeleting-machine, the adjustable movable guard C, constructed substantially in the manner described, as and for the purposes set forth.
2. In combination with the chute or race A of an eyeleting-machine, the rotative feed-cylinder D, as constructed with the flexible rubber fingers F, as and for the purposes set forth.
3. The combination of a rotary feed-cylinder, D, and friction-disk G with a hopper, K, all substantially as and for the purposes set forth.
4. The frictional device consisting of the disk G, spiral torsion-spring H, and adjustable bearing P, in combination with the vertical shaft E and rotative feed-cylinder D, all being arranged substantially as and for the purposes set forth.

CHAS. E. SAWYER.

Witnesses:

SYLVENUS WALKER,
H. S. TALBOT.