

G. H. WEBB.
COTTON GINS.

No. 181,546.

Patented Aug. 29, 1876.

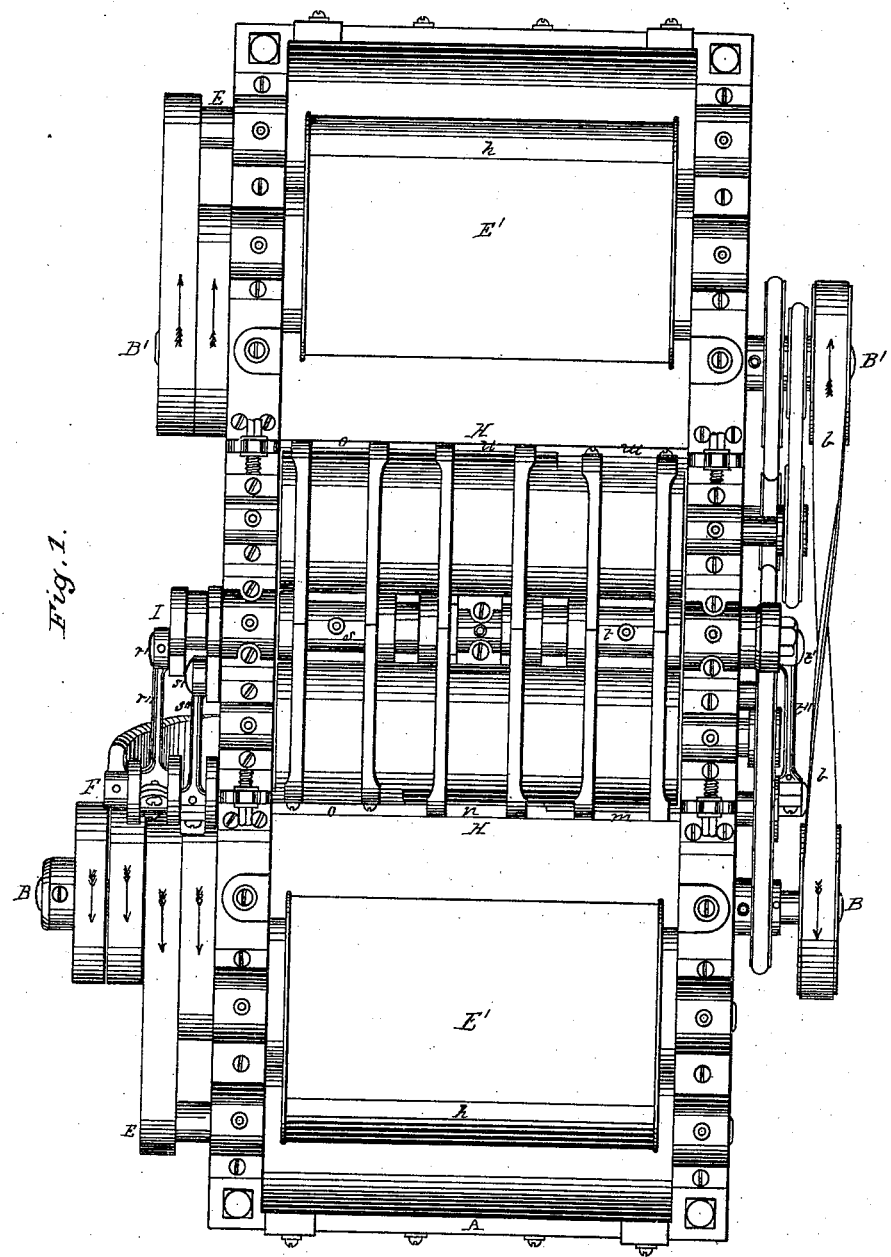

Fig. 1.

Witnesses
 Philip F. Larner
 A. B. Cauldwell

Inventor:
 George H. Webb
 By *Wm. Wood*
 Attorney

G. H. WEBB.
COTTON GINS.

No. 181,546.

Patented Aug. 29, 1876.

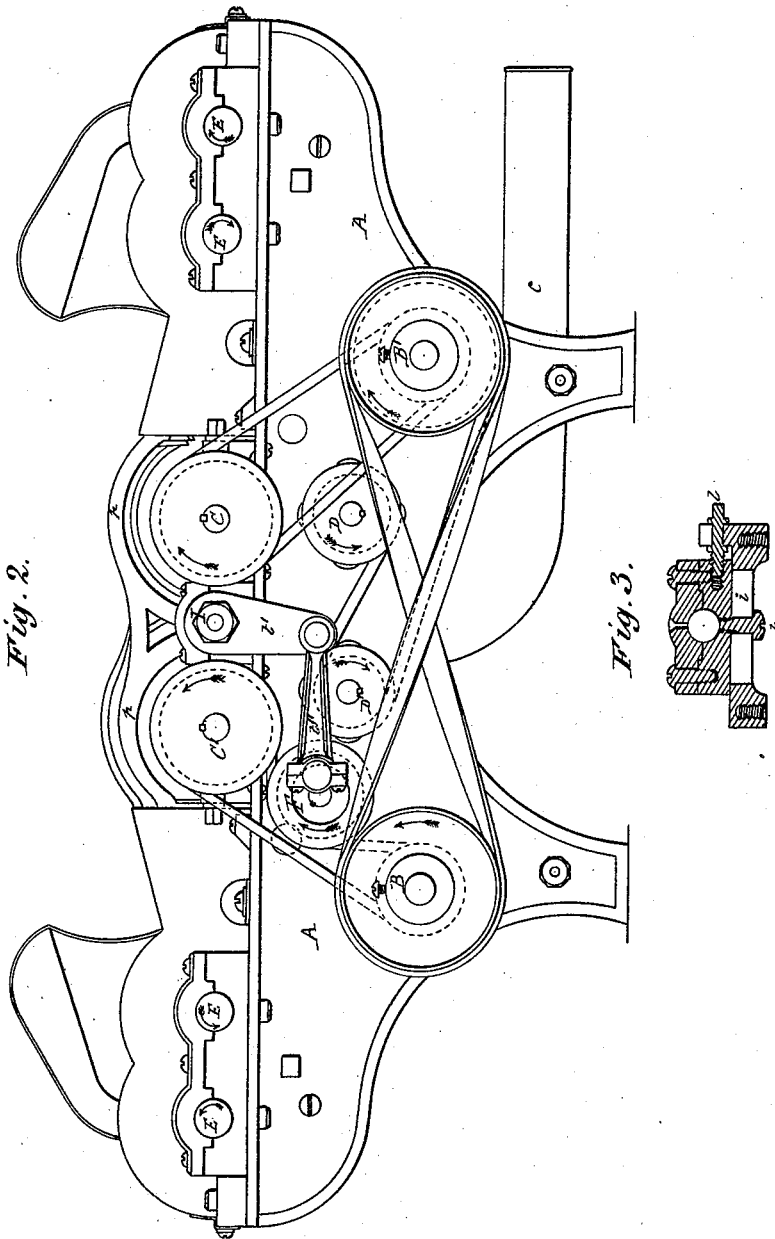

Fig. 2.

Fig. 3.

Witnesses:
Philip F. Larned
A. B. Caldwell.

Inventor:
George H. Webb
By Wm. Wood
Attorney.

G. H. WEBB.
COTTON GINS.

No. 181,546.

Patented Aug. 29, 1876.

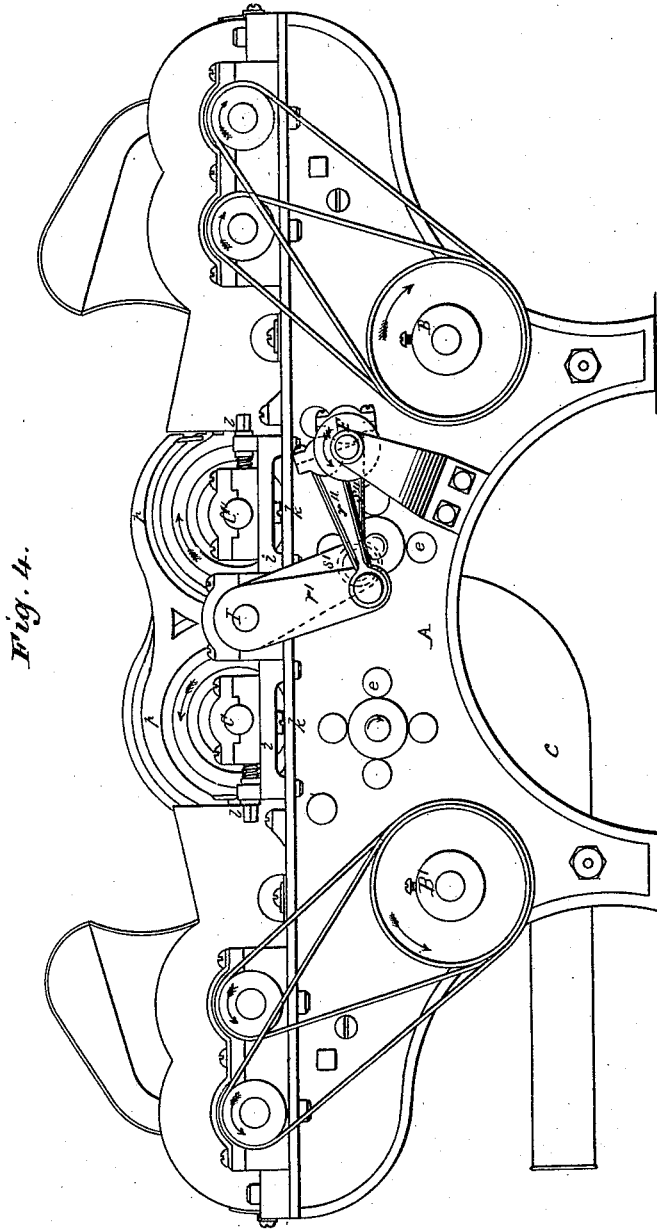

Fig. 4.

Witnesses:
Philip J. Larner
A. B. Caudwell

Inventor:
George H. Webb
By *[Signature]*
Attorney

G. H. WEBB.
COTTON GINS.

No. 181,546.

Patented Aug. 29, 1876.

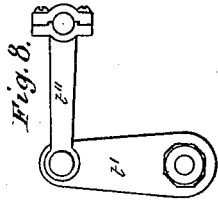

Fig. 8.

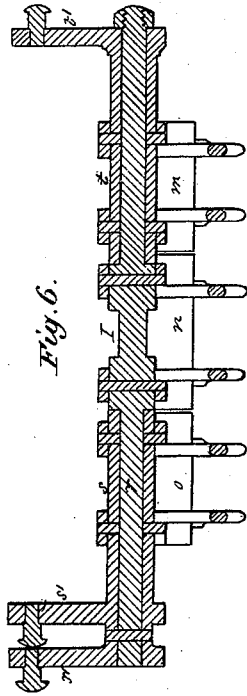

Fig. 6.

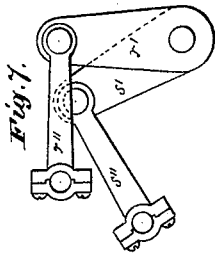

Fig. 7.

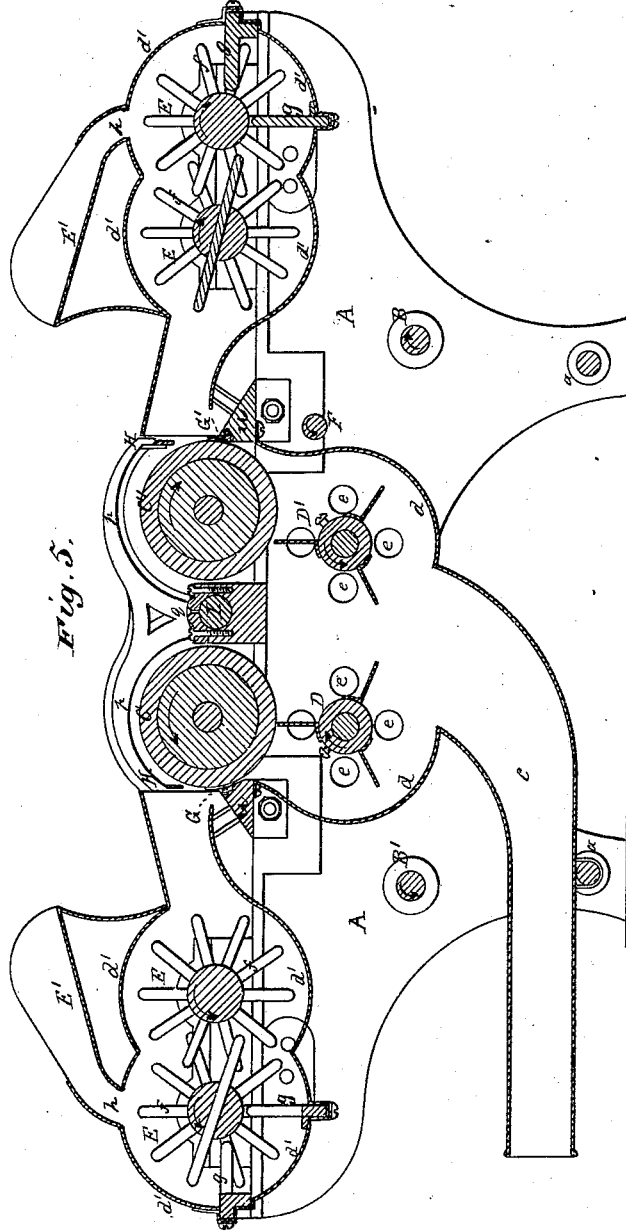

Fig. 5.

Witnesses:
Philip J. Larned
A. B. Cauldwell

Inventor:
George H. Webb,
By *Wm. M. Mott*
Attorney

UNITED STATES PATENT OFFICE.

GEORGE H. WEBB, OF PAWTUCKET, RHODE ISLAND.

IMPROVEMENT IN COTTON-GINS.

Specification forming part of Letters Patent No. **181,546**, dated August 29, 1876; application filed March 4, 1876.

To all whom it may concern:

Be it known that I, GEORGE H. WEBB, of Pawtucket, in the county of Providence and State of Rhode Island, have invented certain new and useful Improvements in Cotton-Gins; and I do hereby declare that the following specification, taken in connection with the drawings furnished and forming a part of the same, is a true and complete description of my invention, and of a machine embodying the same.

My improvements relate to that general class of cotton-gins which are known as "roller-gins," and to that particular class in which a reciprocating knife and a stationary knife are employed in combination with a revolving roll.

The main feature of my invention consists in the combination, with a stationary knife and a roller, of a reciprocating knife constructed in parts or sections, and provided with actuating mechanism which alternately reciprocates the several parts or sections.

In knife and roller gins, as heretofore constructed, reciprocating knives have been employed of a length equal to the length of the roll. The requisite rapid reciprocating motion of these knives induces great wear of the working parts, and the machines are, therefore, short-lived, and readily get out of order.

By having the knife divided into parts or sections, the length of all the sections in the aggregate being equal to the length of the roll, and operating the sections alternately, I am enabled to secure an easier movement and less wear of the parts. Moreover, as each part or section of the knife is comparatively short, and provided with two strong arms, said part or section is less liable to spring, and thereby fail to properly operate in conjunction with the roll.

My sectional knife is driven by a complex reciprocating rock-shaft, composed of a solid central shaft, and as many concentric hollow shafts or sleeves as there are knife-sections to be operated.

In order to fully balance the reciprocating knives, and to reduce the wear of the working parts to a minimum, and at the same time to economize in power, and increase the working capacity of the machine, I duplicate my

knives and roll, so that each portion of the rock-shaft, at each of its movements to and fro, causes a knife to operate with one of the two rolls; and this combination of duplicated balanced sectional knives, mounted upon vibrating arms, and a sectional rock-shaft with two ginning-rolls constitutes another portion of my invention.

I am aware that in belt-gins, as heretofore constructed, vibrating knives have been operated in vertical slides by means of slotted arms and a rock-shaft located centrally between the knives. It will be seen that my sectional knives cannot be practically operated in such slides by means of slotted arms, because of the great speed at which my knives are vibrated, and also because of the necessity for having the ends of each sectional knife closely adjacent to each other. Otherwise there would be a clogging of the fiber and seed at those points.

My invention further consists in the combination, with one or more reciprocating knives and a stationary knife, of a roller mounted in adjustable journal-boxes, whereby the roll may be set not only with relation to the stationary knife, but also with relation to the reciprocating knife or knives.

I am aware that in gins which embody either revolving knives or revolving beaters, for co-operating directly with the roll, said roll has been mounted so as to be adjustable with relation to the stationary knife only, and I therefore do not broadly claim as of my invention an adjustable roller in a knife-gin.

Another portion of my invention consists in the combination, with suitable roller ginning mechanism, of two or more toothed openers, one of which receives the cotton from the feeding-platform, passes it to the next opener, and thence to other openers, or direct to the ginning mechanism.

I am well aware that in roller-gins, as heretofore constructed, the cotton has been passed from the feeding-platform through feeding-rolls, and from thence thrown to the ginning mechanism by a revolving toothed drum or roll. The opening effect sought by me is not attained with such a combination of mechanism, for the toothed drum simply throws the cotton toward the ginning mechanism with-

out thoroughly opening the tufts as they exist in the cotton-boll. The feeding-rolls in such gins cannot well be set so as to hold the tufts against the action of the toothed drum without crushing the seed in the cotton, which would render the proper operation of the ginning mechanism practically impossible.

To more particularly describe my invention I will refer to the accompanying drawings, in which—

Figure 1, Sheet 1, represents a complete machine in top view. Fig. 2, Sheet 2, represents the same machine in side elevation, viewed from the left hand, Fig. 1. Fig. 3, Sheet 2, represents a journal-box of one of the ginning-rolls. Fig. 4, Sheet 3, represents the machine in side elevation, viewed from the right hand, Fig. 1. Fig. 5, Sheet 4, represents the machine in central longitudinal vertical section. Fig. 6, Sheet 4, represents, in longitudinal section, the complex rock-shaft which operates the reciprocating beaters. Figs. 7 and 8, Sheet 4, represent in side view the levers and links which operate the complex rock-shaft.

A denotes one of two side plates, which, with tie-bolts *a* and end pieces, constitute the main frame of the machine. The frame shown is adapted for a double-roller machine having stationary and reciprocating knives in duplicate. In this instance the frame is shown in a desirable form, having four legs, (two on each side plate,) and having an outline and area designed to accommodate the requisite shafting and other mechanism.

B denotes the main driving shaft, provided with tight and loose pulleys, as shown in Fig. 1. In this double machine a second shaft, at B', is also employed as a driver, the two being geared together by the crossed belt *b*.

C and C' denote the ginning-rolls, which are revolved in opposite directions. D and D' denote revolving fan-doffers, located below the ginning-rolls, and arranged to free them from the cotton as fast as it is ginned. The doffers rapidly revolve toward each other, and deliver the cotton downward, driving it forcibly out of the chute, as at *c*. A web, as at *d*, extends from one side plate to the other, and constitutes an inclosing-chamber, having an interior outline adapted to aid the doffers in driving a blast through the chute, the incoming air being drawn through the several openings in the side plates, as shown at *e*.

E denotes in each instance one of four openers. Two of them are located at each end of the machine. These openers are rolls provided with large, strong, blunt, well-rounded, smooth teeth, as at *f*, coarsely set, and so arranged longitudinally in the rolls that those in one opener cannot engage with those in the other. The two openers nearest the ends of the machine operate in conjunction with stationary teeth, as at *g*, of a similar character to those in the openers. These stationary teeth are attached to the frame of the machine, and are arranged vertically in one row and horizontally

in the other, as clearly shown in Fig. 5, at each end of the machine.

E' in each instance denotes one of two feeding-platforms with flanged sides. An opening at the foot of the table, as at *h*, communicates with the opener-chamber formed by the casing *d'*. The opener-chamber has an extension projecting toward the ginning knives and roller, and this extended portion constitutes a trunk through which the cotton is thrown to the ginning mechanism.

F denotes a revolving crank-shaft, by which the reciprocating knives are actuated, as will hereafter be described.

I have thus far designated all the revolving portions of the machine. Each pair of openers E revolve in the same direction, and toward their respective ends of the machine. They are driven by belting from the two shafts B and B', as shown in Fig. 4. The shaft B also drives the ginning-roll C and the shaft F, which actuates the reciprocating knives. The two doffers are driven by a belt from the shaft B', all of which is clearly shown in Figs. 1 and 2, Sheets 1 and 2.

The journal-boxes of the ginning-rolls (shown in detail in Fig. 3, Sheet 2) are arranged to slide longitudinally. Each box is mounted on a slotted bed, as at *i*, which is bolted to the frame of the machine. A holding or set screw, as at *k*, passes upward through this slot into the lower half of the box, and an adjusting-screw, as at *l*, provided with collars, occupies an open vertical slot at one end of the bed *i*, by means of which the box may be moved toward the center of the machine, thus moving the roll to any required position with relation to its respective knives.

G and G' denote the stationary knives. Each is secured rigidly at its ends to the side plates, and has its knife-edge closely adjacent to the periphery of its respective ginning-roll, and is located with its edge a little below the plane of the axis of the roll. The bevel of the knife-edge is inclined downward from the face of the roll.

I have now to describe the reciprocating knives and their peculiar construction. Each reciprocating knife is shown at H. Each is divided, in this instance, into three sections, as at *m*, *n*, and *o*. Each section is about one-third the length of a ginning-roll. The duplicate sections are connected by arms, as at *p*, each of which is provided with a hub, as at *q*.

The rock-shaft at I is complex in its construction, and, for knives in three sections, is composed of the main shaft *r*, to which the duplicate central knife-sections *n* are attached; the sleeve *s*, to which the duplicate sections *o* are attached; and the sleeve *t*, to which the duplicate sections *m* are attached.

The main rock-shaft and both sleeves are connected with the revolving crank-shaft F as follows: main rock-shaft by means of lever *r'* and link *r''*; sleeve *t* by lever *t'* and link *t''*; and sleeve *s* by lever *s'* and link *s''*.

It is to be understood that these knife-sec-

tions are so set on the sleeves and on the main rock-shaft, and that their levers, links, and cranks are so arranged, that no two sections of either knife can move together upon the stationary knife. As shown in the drawings these sections move in the following order: *m o n*, &c.

In operation, the several revolving portions of the machine are driven at a high speed in direction indicated by the several arrows. The reciprocating knives are driven as rapidly as may be desirable. The cotton, with its seed, is fed by a tender to the machine, by the way of the platforms *E'*, through space *h*, where it is taken by the fingers of the adjacent opener, carried by them past the horizontal and vertical fingers *g*, which contribute to the opening process. The second opener takes the cotton from the fingers of the first one, and, throwing it through the trunk, delivers it in front of and in contact with its respective stationary knife, roller, and reciprocating knife. The ginning-roller surface adjacent to the knives moves upward, and carries with it the fiber and the seed attached thereto, until the reciprocating knife, in its descent upon the beveled surface of the stationary knife, detaches the seed from the fiber.

As long as the seed has fiber of any valuable length attached, the roller maintains control over it; but, when thoroughly cleaned, the seed falls free upon the incline at *v*, and drops beneath the machine.

It is to be understood that the ginning-rolls may be made in accordance with any of the methods heretofore employed in the construction of rolls for use with knives in cotton-gins.

It is well known that roller-gins are capable of operating with less injury to the staple than the saw-gins, which have long been and are now in general use; but the limited working capacity of roller-gins, as heretofore constructed, has served as a bar to their general adoption.

It is clear that the capacity of a reciprocating-knife and roller gin depends upon the rapidity with which the knives are reciprocated. As heretofore constructed, the knives being in one length and unbalanced, their rapid movement must obviously result in constant shocks and jars to the machine. One portion of my improvement, which consists in balancing one knife by another, materially lessens this shock and jar, and this result is attained whether or

not the knives are made in sections, as shown. Added to this advantage, I have an increased capacity in the machine without a proportionate increase of power expended, for the termination of the upward movement of one knife on one side of the rock-shaft is rendered easy by the termination of the downward movement of the knife on the opposite side of the shaft, which, while moving downward, is meantime performing its work. By having each knife constructed in sections, as shown, and operated separately, the shock and jar to the working parts is reduced to a minimum.

Having thus described my invention, I claim as new, to be secured by Letters Patent—

1. The combination, with a ginning-roll and a stationary knife, of a reciprocating knife, constructed in two or more lengths or sections, and mechanism for independently reciprocating each knife-section, substantially as described.

2. The combination, with a pair of ginning-rolls and two stationary knives, of two balanced reciprocating sectional knives, mounted on arms which project from opposite sides of a complex rock-shaft, and mechanism for reciprocating said balanced knives, and causing them alternately to co-operate with their respective stationary knives and ginning-rolls, substantially as described.

3. The combination, with a reciprocating knife and a stationary knife, of a ginning-roll, mounted in sliding journal-boxes provided with adjusting and holding devices, substantially as described, whereby the ginning-roll may be moved to or from both the reciprocating and stationary knives, and firmly set in any desired position, for the purpose specified.

4. The combination, with roller-ginning mechanism, of a feeding-platform, stationary teeth, and two or more revolving toothed openers, arranged to operate in connection with the stationary teeth, and with each other, for opening the cotton, and located with reference to the ginning mechanism and to a communicating trunk or chamber, substantially as described, whereby the cotton, when opened, is delivered continuously to the ginning mechanism, as set forth.

GEORGE H. WEBB.

Witnesses:

WM. H. HASKELL, Jr.,
E. S. BINFORD.