

E. W. FAWCETT.
STRAW-CUTTER.

No. 181,567.

Patented Aug. 29, 1876.

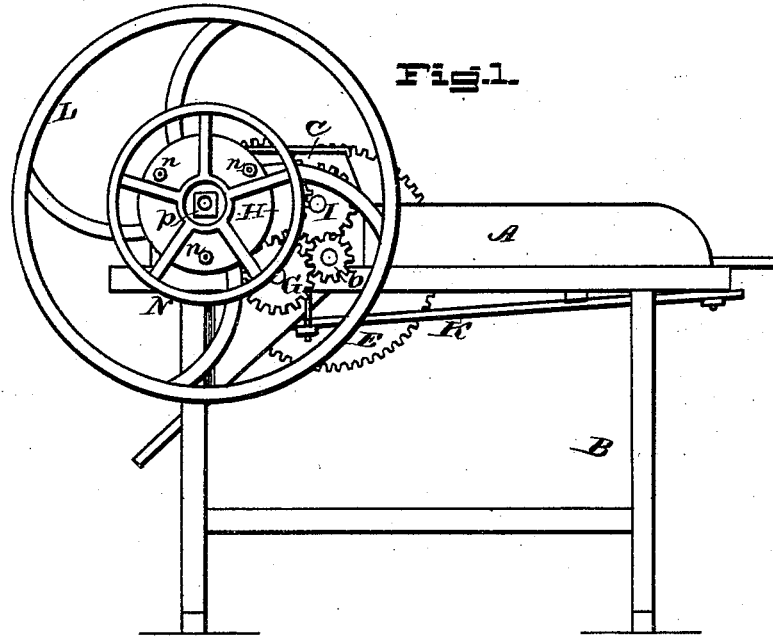

Fig. 1.

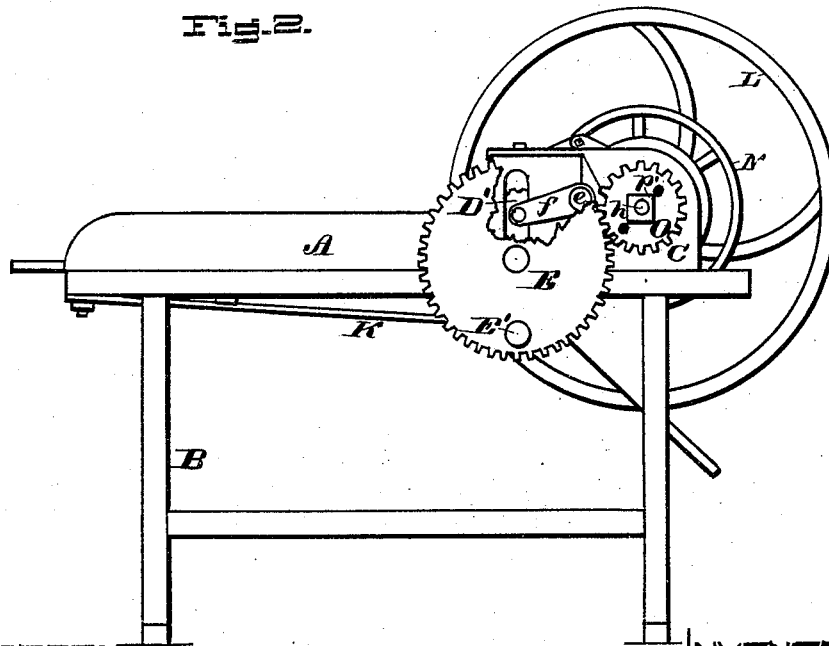

Fig. 2.

WITNESSES:

Jas. F. Dutton,
Mc J Sullivan.

INVENTOR:

Edward W. Fawcett.

PER

H. S. Abbott.

ATTORNEY.

E. W. FAWCETT.
STRAW-CUTTER.

No. 181,567.

Patented Aug. 29, 1876.

Fig. 3.

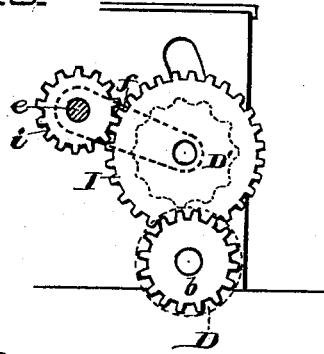

Fig. 4.

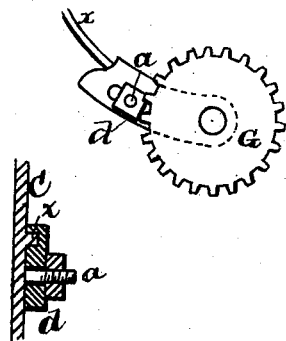
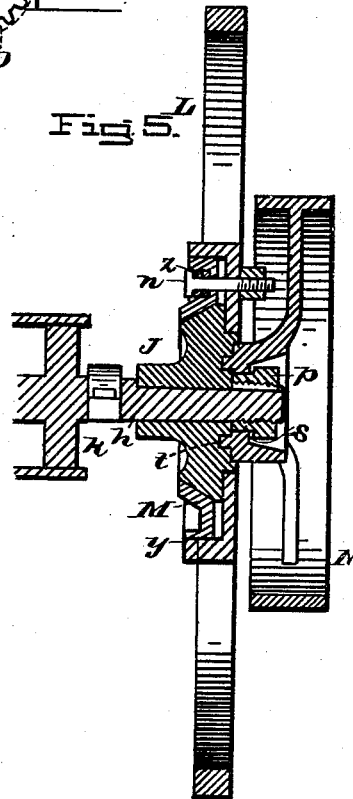

Fig. 5.



WITNESSES:

Jas. S. Dubamel,
Mo J Sullivan

INVENTOR

Edward W. Fawcett.

PER

A. T. Abbot.

ATTORNEY.

E. W. FAWCETT.
STRAW-CUTTER.

No. 181,567.

Patented Aug. 29, 1876.

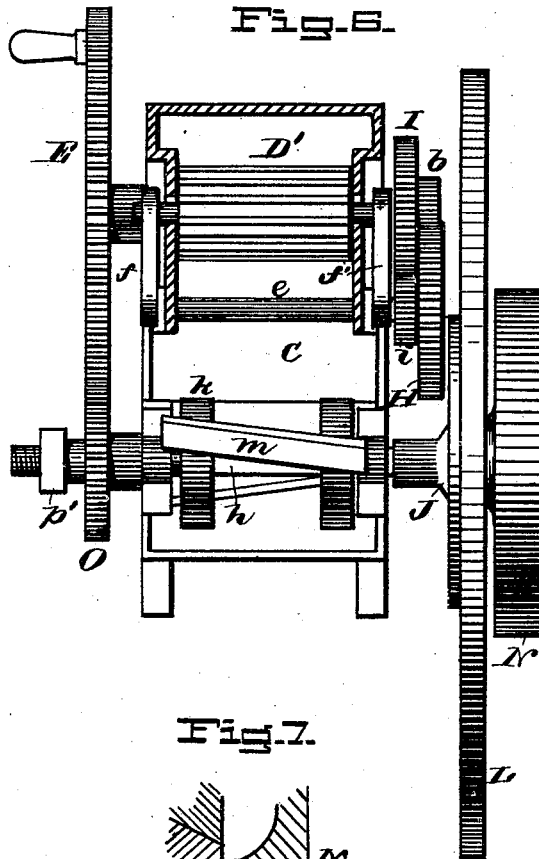

WITNESSES:

Geo. S. Duhamel
H. B. Brown

INVENTOR.

E. W. Fawcett

PER

A. S. Abbot

ATTORNEY

UNITED STATES PATENT OFFICE

EDWARD W. FAWCETT, OF SALEM, OHIO.

IMPROVEMENT IN STRAW-CUTTERS.

Specification forming part of Letters Patent No. **181,567**, dated August 29, 1876; application filed June 23, 1876.

To all whom it may concern:

Be it known that I, EDWARD W. FAWCETT, of Salem, in the county of Columbiana and State of Ohio, have invented certain new and useful Improvements in Feed-Cutters, of which the following is a specification:

My invention relates to the class of feed-cutters which have rotating cutters and feed-rollers; and it consists in the construction and arrangement of certain parts thereof, as will be hereinafter more fully set forth.

In order to enable others skilled in the art to which my invention appertains to make and use the same, I will now proceed to describe its construction and operation, referring to the annexed drawings, which form a part of this specification, and in which—

Figure 1 is a side elevation. Fig. 2 is a side elevation—opposite side from Fig. 1. Figs. 3 and 4 are detail views. Fig. 5 is a vertical section through the fly-wheel. Fig. 6 is a top view with the casing removed. Fig. 7 is a cross-section of the pulley N.

A represents the ordinary feed-box, supported upon frame-work B, and having at the front end the metal casing C, which incloses the feed-rollers and rotating cutters, the upper front portion of said casing being hinged, so as to be thrown back when required. D is the lower feed-roller, having its journals extended beyond the casing C. Upon one of these journals is secured a large cog-wheel, E, having crank E'. On the other journal of said feed-roller is secured a pinion, *b*, which meshes with a cog-wheel, G, mounted on a stud projecting from a slotted arm, *d*, held to the casing C by a bolt, *a*. The arm *d* may be adjusted on the arc of a circle and fastened at any point desired, a raised guide, *x*, on the casing fitting in a groove on the arm and guiding its movements. The cog-wheel G meshes with another cog-wheel, H, fastened on the projecting end of a shaft, *e*, that has its bearings in the sides of the case C. On this shaft, on each side of the machine, is fastened a rigid arm, *f*, and in the outer ends of these arms are placed the journals of the upper feed-roller D'. One of these journals is extended, and has a cog-wheel, I, thereon, which meshes with a pinion, *i*, on the shaft *e*, at the side of the cog-wheel H.

By the arrangement of the shaft *e* with the two arms *f* rigidly attached thereto, and the upper feed-roller having its journal-bearings in the ends of said arms, said upper feed-roller is maintained parallel with the lower roller, while its pinion I is maintained in gear with the double pinion H *i*, as shown. The journals of the upper roller D' move in vertical slots in the sides of the casing C, and the roller held down in the usual manner by a spring, K, under the box A.

By the adjustable plate or arm *d* (carrying the pinion G and the guide *x*) being concentric with the double pinion H *i*, said intermediate pinion G may be set to mesh with a pinion of any desired size on the lower roller, for the purposes of changing the length of cut.

h is the fly-wheel shaft, upon which, within the casing, are secured the disks *k*, which carry the cutters *m*.

In order to prevent accidents that might be caused by any hard substance being fed to the knives, I construct the fly-wheel as follows: Attached to or forming part of the fly-wheel L is a truncated cone or frustum, J, which is rigidly attached to the shaft *h*, said frustum being clamped between the center disk of the wheel on one side and a ring, M, on the other, the ring being secured to the wheel by feathers *y* and bolts *n*, and is provided with recesses for confining rubber or other elastic material, *z*, under the bolt-heads, for the purpose of equalizing the friction on the cone in case its surface is irregular.

In lieu of the frustum, a simple disk may be used, clamped in the same manner.

A very moderate tightening of the nuts on the bolts *n* is sufficient to prevent the wheel from turning on the frustum when the machine is simply doing its legitimate work, and the knives may be stopped instantly, when moving at a high speed, without proving destructive to the machine.

p is the nut, screwed on the end of the shaft *h* for securing the fly-wheel. The inner end of this nut is rounded and reduced in diameter to near the middle of its depth, leaving a shoulder, *s*, at that point, the reduced portion being a trifle less in depth than the thickness of the center plate of the pulley N, so that, when the pulley is not on, the inner end of

the nut will tighten against the hub of the fly-wheel; but when the pulley is on, the shoulder *s* of the nut tightens against the pulley-plate, and the round part serves to center it, thus requiring but little adjustment of the nut to make the change. A similar nut, *p'*, is provided for the other end of the shaft *h*, and recesses made in the pinion *O* to receive the studs or lugs *t* of the pulley, and prevent its turning on the shaft, so that the pulley may be readily attached to either end of the shaft, as desired. The center plate of the fly-wheel has also recesses or holes for the lugs *t* of the pulley *N*. The pinion *O* meshes directly with the cog-wheel *E*, as shown.

Having thus fully described my invention, what I claim as new, and desire to secure by Letters Patent, is—

1. The shaft *e*, with arms *f f* rigidly attached thereto, and carrying the upper feed-roller *D'*, in combination with the gearing, as described, whereby the roller *D'* is allowed to adjust to

the thickness of the material fed to the cutting-knives, substantially as set forth.

2. The adjustable plate or arm *d*, carrying the pinion *G*, in combination with the gearing, as described, whereby the speed of the feeding mechanism may be changed, substantially as shown and described.

3. The fly-wheel *L*, provided with the loose ring *M*, for clamping the wheel on a frustum or disk, *J*, substantially as and for the purposes set forth.

4. The ring *M*, provided with recesses for the reception of elastic cushions *z*, in combination with the wheel *L*, bolts *n*, and frustum or disk *J*, for the purposes herein set forth.

In testimony that I claim the foregoing as my own I affix my signature in the presence of two witnesses.

EDWARD W. FAWCETT.

Witnesses:

RUSH TAGGART,
LUCIEN L. GILBERT.