

H. P. FRY.
WASHING-MACHINE.

No. 181,570.

Patented Aug. 29, 1876.

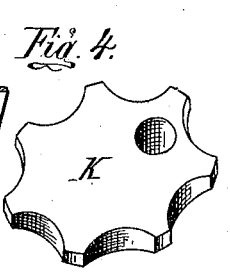
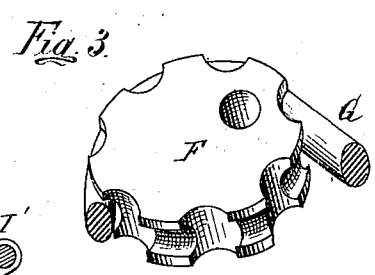
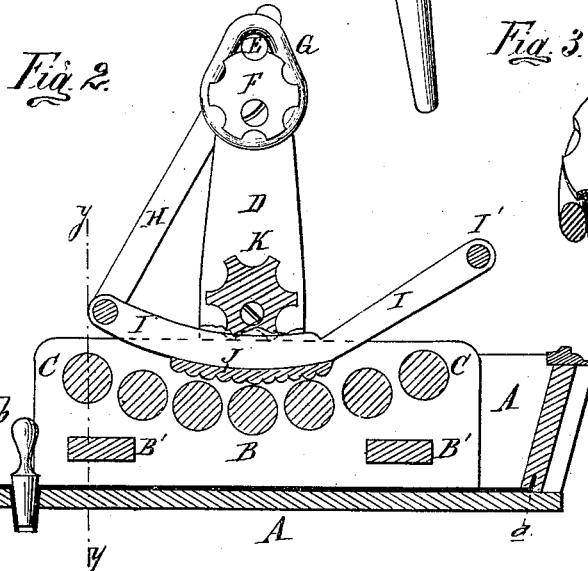
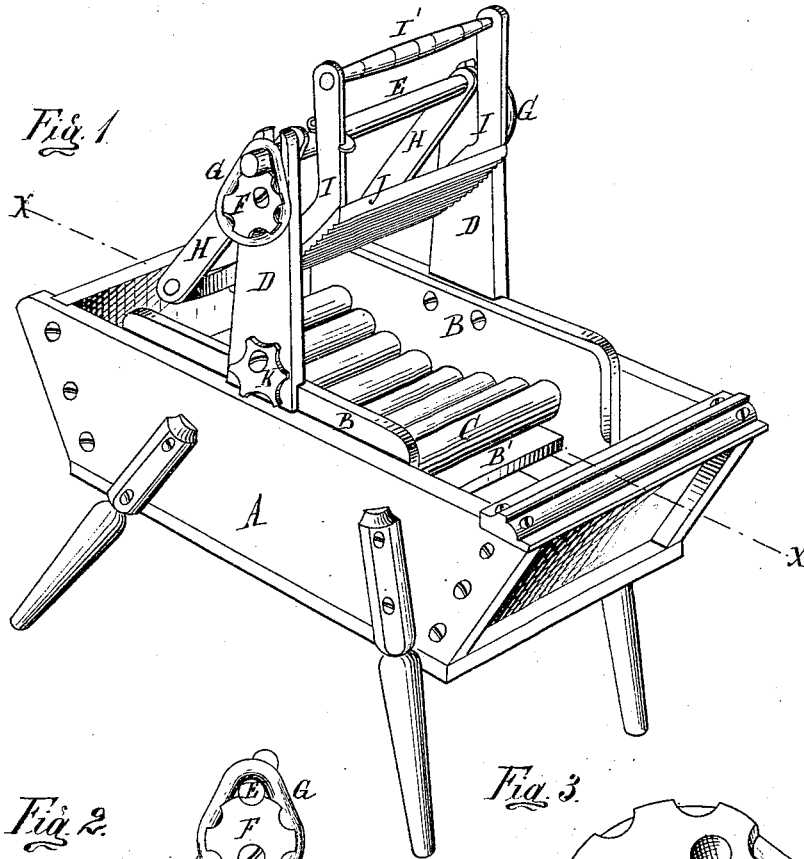

Attest:
 Edward Parthel
 Charles J. Hunt

Inventor:
 H. P. Fry
 By Atty
 J. S. Sprague

H. P. FRY.
WASHING-MACHINE.

No. 181,570.

Patented Aug. 29, 1876.

Fig. 5.

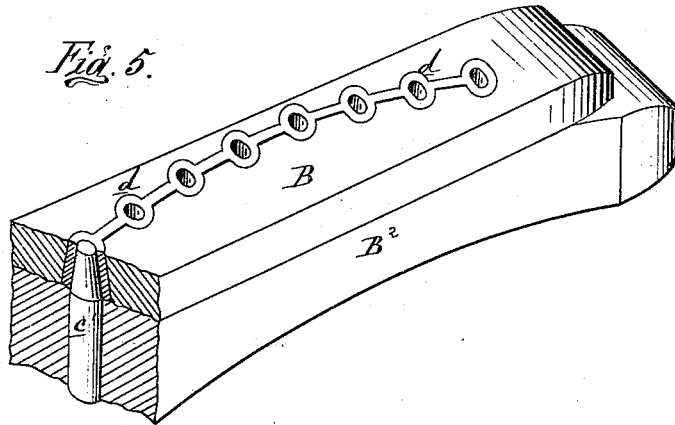

Fig. 6.

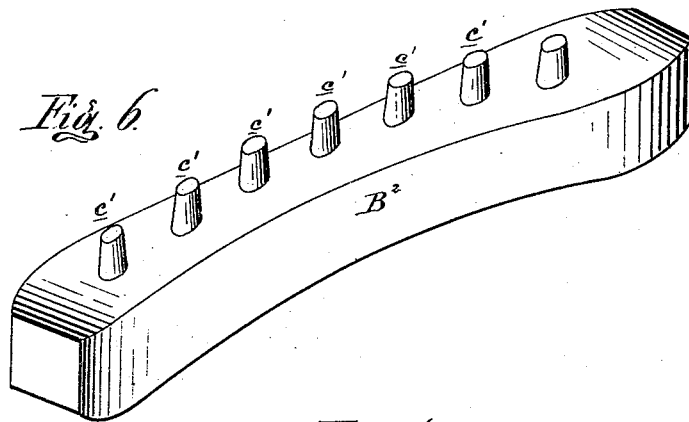
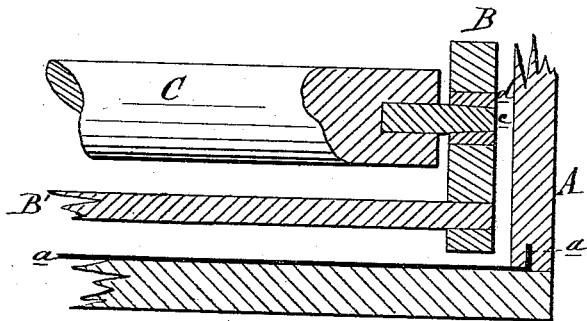

Fig. 7.



Attest:
 Edward Parshel.
 Charles J. Hunt

Inventor:
 H. P. Fry
 By Atty
 Geo. S. Sprague

UNITED STATES PATENT OFFICE.

HENRY P. FRY, OF LESLIE, MICHIGAN.

IMPROVEMENT IN WASHING-MACHINES.

Specification forming part of Letters Patent No. **181,570**, dated August 29, 1876; application filed June 2, 1876.

To all whom it may concern:

Be it known that I, HENRY P. FRY, of Leslie, in the county of Ingham and State of Michigan, have invented an Improvement in Washing-Machines, of which the following is a specification:

The nature of my invention relates to an improvement in washing-machines of that class wherein the fabrics are cleansed by friction between a series of rollers transversely journaled in the tub and a swinging or vibrating rubbing-board.

The invention consists in combining with a washing-machine the peculiar devices for raising and lowering the rubbing-board without changing the position of the roller-frame; in the peculiar form of boxes, and manner of making them, in which the rollers are journaled, and in the general construction and arrangement of the various parts, as more fully hereinafter set forth.

Figure 1, Sheet 1, is a perspective view. Fig. 2 is a longitudinal vertical section at *xx* of Fig. 1. Fig. 3 is a detached perspective view of an eccentric rock-shaft bearing, and a portion of the elastic cord which holds the rock-shaft thereon. Fig. 4 is a similar view of a notched eccentric button, for supporting the frame-standards. Fig. 5, Sheet 2, is a perspective view, showing the manner of casting the bearings in a roller-frame. Fig. 6 is a perspective view of the core-print pattern used in the process of forming the roller-bearings. Fig. 7 is a cross-section at *yy*.

In the drawing, A represents the body of the machine in the form of a rectangular box. Before the wooden bottom is secured to the edges of the sides a zinc bottom lining, *d*, has a flange turned up at each side and end, which flange is let into a narrow cut or groove in the lower edge of the frame sides, after which the bottom board is placed over it and secured.

The vent-hole in the bottom is bushed, as seen in Fig. 2, to prevent water from passing under the lining, when the plug *b* is withdrawn.

In the body is placed a removable frame composed of two vertical side boards, B B, joined by mortised girts B¹ at each end. Between the sides are transverse rollers C, jour-

naled therein, and arranged in the arc of a circle. The journal for each roller is a conical iron pin or gudgeon, *c*, inserted in each end of the wooden roller.

To form the bearings for these journals in the boards B, I take each of the latter and bore through it holes for the several journals, in the same arc of the circle that the rollers are to be arranged in, which holes are larger in diameter than the journals. I then cut a "sprue" or channel from each hole to the next, and then lay the board on a pattern-plate, B², Fig. 6, having a set of journal-patterns, *c'*, projecting like core-prints from its surface into the axes of the holes in the board, into which molten Babbitt metal is then run, which forms a bushing, *d*, Figs. 5 and 7, for each journal, all of which bushings are thus cast solid, and prevented from working loose in their holes, as they would if cast separately. D D are standards on the outer sides of the frame B, each slotted at the top to receive a rocking bar or rock-shaft, E, whose projecting end rests in one of the notches in the periphery of a bearing, F, eccentrically pivoted to the outside of the standard below it. The periphery of the eccentric has a number of these notched bearings cut in it, and by revolving it the rocking bar may be raised or lowered. The end of the rocking bar is held down by an elastic rubber ring, G, passing around the bar and the eccentric, which latter is grooved to receive it, as seen in Fig. 3. I is a rubbing-frame, suspended at one end by links H H from the rock-shaft, and at the other end is provided with a girt, I', which serves as a handle, by which the frame can be oscillated over the series of rollers below, and the arc-shaped rubbing-board J, which is secured to its under side, can be pressed down upon said rollers, or upon any fabric interposed between them. The under surface of the rubbing-board is transversely corrugated, as shown.

As the fabrics may vary in bulk or thickness the rocking bar and the rubbing-frame may be raised or lowered by shifting the eccentric bearings of the rocking bar.

Ordinarily the frame B may rest upon the bottom of the box; but from the depth of the suds, or the latter becoming foul, especially near

the bottom, in which the dirt settles, it becomes desirable to raise the frame B and its attachments bodily. It can be done by rotating a stelliform rest, K, eccentrically pivoted to the outer face of each standard D, which star-shaped rest K bears upon two points on the top edge of the box, and is thus adjusted to raise or lower said standards.

What I claim as my invention, and desire to secure by Letters Patent, is—

1. The grooved and notched eccentric bearings, in combination with the standards and rocking bar of a washing-machine, substantially as herein described.

2. The combination, with the side boards

B B¹ of the roller-frame, of the connected metallic journal-boxes, formed by casting the metal in the said side boards, substantially as described.

3. In a washing-machine, the arrangement of the frames and standards, rollers, and rubbing-board, the eccentric bearings and buttons, in combination with the body of a washing-machine, substantially as and for the purposes set forth.

HENRY P. FRY.

Witnesses:

H. S. SPRAGUE,
EDWARD BARTHEL.