

C. A. BLESSING.
BATH-TUB.

No. 181,625.

Patented Aug. 29, 1876.

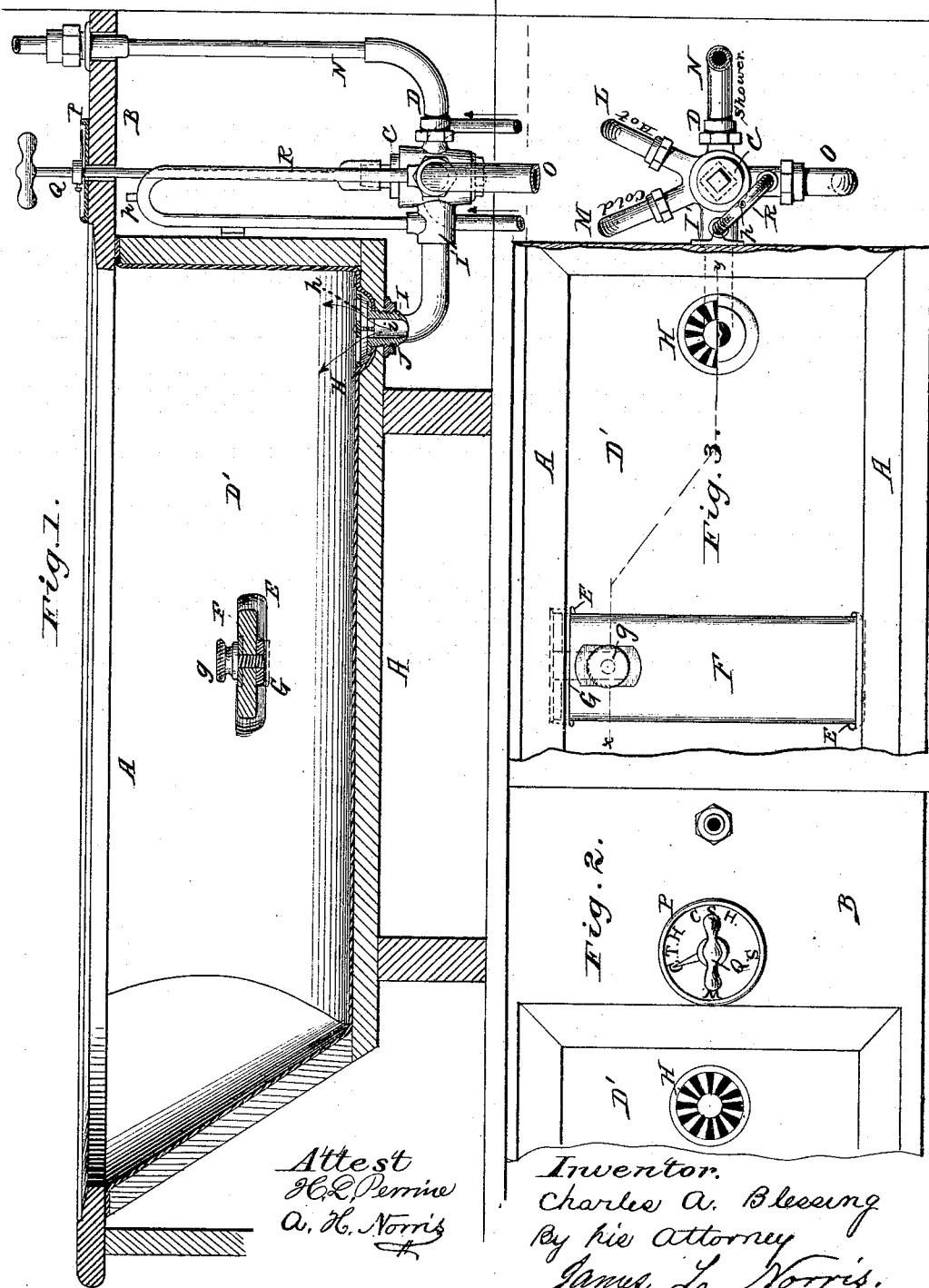

Fig. 1.

Fig. 3.

Fig. 2.

Attest
J. C. Perrine
A. H. Norris

Inventor.
Charles A. Blessing
By his Attorney
James L. Norris.

C. A. BLESSING.
BATH-TUB.

No. 181,625.

Patented Aug. 29, 1876.

Fig. 4.

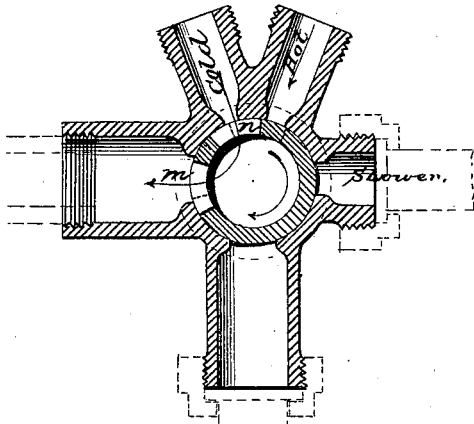

Fig. 5.

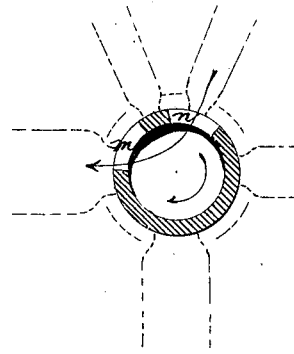

Fig. 7.

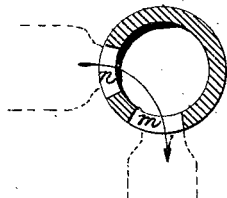

Fig. 6.

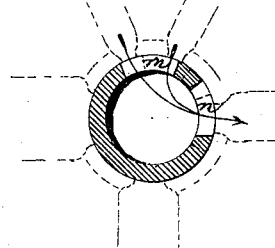

Fig. 8.

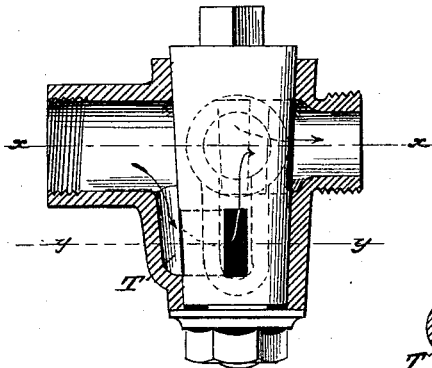

Fig. 9.

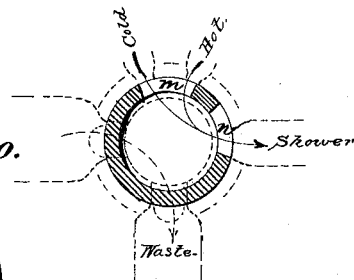
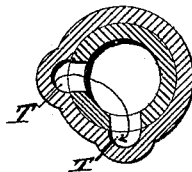

Fig. 10.



Attest:
H. L. Perrine
A. H. Norris.

Inventor.
Charles A. Blessing
By his Attorney
James L. Norris.

UNITED STATES PATENT OFFICE.

CHARLES A. BLESSING, OF PHILADELPHIA, PENNSYLVANIA.

IMPROVEMENT IN BATH-TUBS.

Specification forming part of Letters Patent No. **181,625**, dated August 29, 1876; application filed August 11, 1876.

To all whom it may concern:

Be it known that I, CHARLES A. BLESSING, of Philadelphia, in the county of Philadelphia and State of Pennsylvania, have invented certain new and useful Improvements in Bath-Tubs, of which the following is a specification:

The present invention relates to improvements in bath-tubs, and has special reference to means for supplying hot and cold water to the tub and a shower-pipe; also, to means for withdrawing the waste-water from the tub, either while the water-supply is connected with the shower-pipe, or while it is not connected.

The invention consists in the combination, with the waste-pipe issuing from the bottom of a bath-tub, of an overflow tube or pipe, which operates in the manner of a siphon, and is so contrived that the water will gradually rise in said tube to the level of the water in the tub, and will run off into the waste-pipe, when the proper amount of water is in the tub. The invention also consists in the combination, with hot and cold water supply pipes, a shower-bath pipe, and a waste-pipe, of a four-way cock, which is so constructed and arranged that the hot and cold water can be admitted through the bottom of the tub, either separately or mixed, and can also be caused to flow into the shower-pipe while the water from the tub is running off through the waste-pipe. The invention further consists in the combination, with a tub having countersunk or struck-up recesses in its sides, of a detachable seat, which is held in place by a sliding clamp and thumb screw.

In the accompanying drawing, Figure 1 is a longitudinal vertical section of a bath-tub having my water supply and discharge devices applied thereto. Fig. 2 is a plan or top view, showing the strainer-key for operating the tub and shower-pipe. Fig. 3 is a plan view of the tub. Fig. 4 represents the four-way cock in position for admitting cold water to the tub. Fig. 5 shows the cock in position for supplying hot water to the tub. Fig. 6 represents the cock in communication with the hot and cold water pipes and the shower-pipe. Fig. 7 exhibits the cock in position for discharging the water from the tub into the waste-pipe. Figs. 8, 9, and 10 represent a

modification of my invention, in which the discharge of the waste-water is taking place while the shower-supply pipe is on.

The tub A (shown in the drawing) is of the usual portable form, and has a molding around its top and sides, so as to give it the proper ornamental finish. B is an extension or board at the top of the tub, which supports the key for operating the supply and waste cocks C; also the coupling D, with which the shower-bath pipe is connected. The interior of the tub is provided with the usual zinc, copper, or other metallic lining, D', in the sides of which are formed, by the swaging or stamping process, cavities or recesses E, for receiving the ends of a removable seat, F, which is retained in position by a sliding clamp, G, bearing against one side of the tub, and secured to the seat by a thumb or clamp screw, g. In the bottom of the tub is an opening, covered by a strainer-plate, H, which has a screw-stem, h, that is screwed into a cross-bar, i, at the top of the combined supply and waste pipe I. Said pipe is flanged at its upper end, and is secured to the tub by means of an external jam-nut, J, screwing on the pipe beneath the tub. The pipe I is connected with the branch I' of a shell or casting containing the cock or valve C, which may be of the ordinary form termed a "four-way cock." The pipes or connections for the hot and cold water are denoted by the letters L M, respectively, the shower-pipe connection by the letter N, and the waste-pipe connection is shown at O. The cock C is made hollow and provided with the openings m n, which, when turned so as to register with the cold-water pipe, as shown in Fig. 4, will serve to admit cold water into the tub through the pipe I. When the cock is turned as shown in Fig. 5, hot water alone is admitted into the tub.

When it is desired to shut off the water-supply from the tub, and to bring the shower-bath into use, then the cock is turned, as shown in Fig. 6, which will cause hot and cold water to flow into the shower-pipe. A reverse movement of the cock will serve to open the communication between the tub and the waste-pipe, so as to enable the waste-water to run off, this position of the cock being shown in Fig. 7. The position of the cock, or the man-

ner of turning the same so as to communicate with the different pipes, is indicated by a fixed dial-plate, P, on the top board B, arranged in proper relation to the key Q, carrying a pointer, used for turning the cock.

The key is separate from the cock; likewise, the different pipes are detachably connected with the shell of the cock, so that the different parts can be readily attached to and removed from the tub. A curved overflow-pipe, R, is connected with the pipe leading into the tub, also with the waste-pipe O, this overflow-pipe operating somewhat in the manner of a siphon, so that when the water in the tub reaches the maximum level or height the water in the overflow-pipe will commence to run and discharge into the waste-pipe, for maintaining the proper level in the tub. The overflow-pipe is provided with an air-opening, p, at the junction of its two vertical legs, as shown in Fig. 1. Instead of making the overflow-pipe like a siphon, as described, it may enter the tub at the high-water level thereof, and communicate at its other end with the waste-pipe. In certain instances it is desirable to permit the water in the tub to run off while the shower-bath is in use; and for permitting this to be done I have contrived a cock of the form shown in Figs. 8, 9, and 10 of the drawing, this cock differing from the one heretofore described in being made longer, and fitting into a correspondingly-extended shell or casing. The lower portion of the shell of the cock is, in this instance, provided with a groove or water-way, T, which receives the water from the tub, and conveys it through the cock into the waste-pipe. The upper part of the cock is properly separated from the lower part by a partition, so that the hot and cold water, either or both, can enter the shower-pipe without mingling with the waste-water from the tub.

I do not confine myself to the exact details of construction and arrangement herein shown and described, for the shower-pipe may be conducted to the side or end of the tub opposite to that where the supply takes place, and the water may also be caused to enter and run off at the side or any other convenient portion of the tub.

The overflow-pipe may be connected to the valve-casing or to the supply and waste pipes,

and the point of attachment may be at the top or at the side of said pipes, as may be found most convenient in fitting the water-supply and waste attachment to the tub, in order to take up as little room as possible outside of the tub.

I wish it to be observed that my attachments can be applied to a bath-tub with ease and facility, and will take up much less space than in the bath-tubs heretofore constructed, thus commending it to more particular public favor. Bath-tubs provided with my attachments are ready for the market and immediate use. I would also remark that the attachments are adapted to wash-basins, sinks, &c., as well as bath-tubs; and I do not wish it to be understood that I restrict my invention as applied only to bath-tubs.

What I claim, and desire to secure by Letters Patent, is—

1. The combination, with the water-supply and waste pipes of a bath-tub and supply-cock, of a siphon-shaped overflow-pipe, connected with the supply and waste pipe, constructed and arranged to operate substantially as described.

2. The combination, with the water-inlet pipe, hot and cold water supply pipes, and waste-pipe of a bath-tub, of a single cock, constructed substantially as described, for admitting hot or cold water separately or together into the tub, and to discharge the same into the waste-pipe, as set forth.

3. The combination, with a shower-bath pipe and pipes for admitting hot and cold water into the shower-pipe, of a single cock, constructed substantially as shown, for permitting a simultaneous flow of water from the tub and into the shower-pipe, substantially as described.

4. The combination, with a bath-tub having recesses in its lining, formed as described, of a removable seat and suitable retaining device therefor, substantially as described.

In testimony that I claim the foregoing I have hereunto set my hand in the presence of the subscribing witnesses.

CHAS. A. BLESSING.

Witnesses:

A. H. NORRIS,
JOS. L. COOMBS.