

S. S. FORMAN & W. CONLEE.
BORING MACHINE

No. 181,662.

Patented Aug. 29, 1876.

Fig 1.

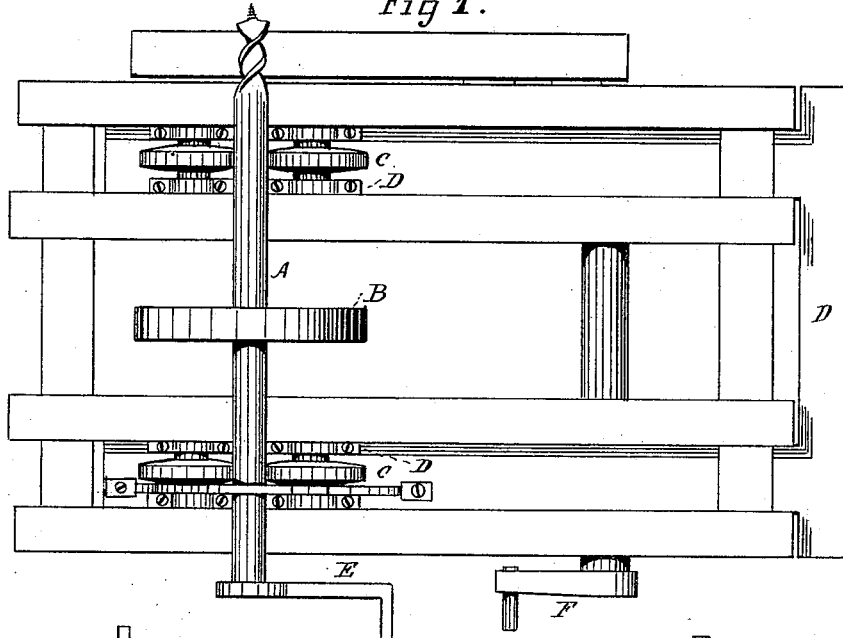
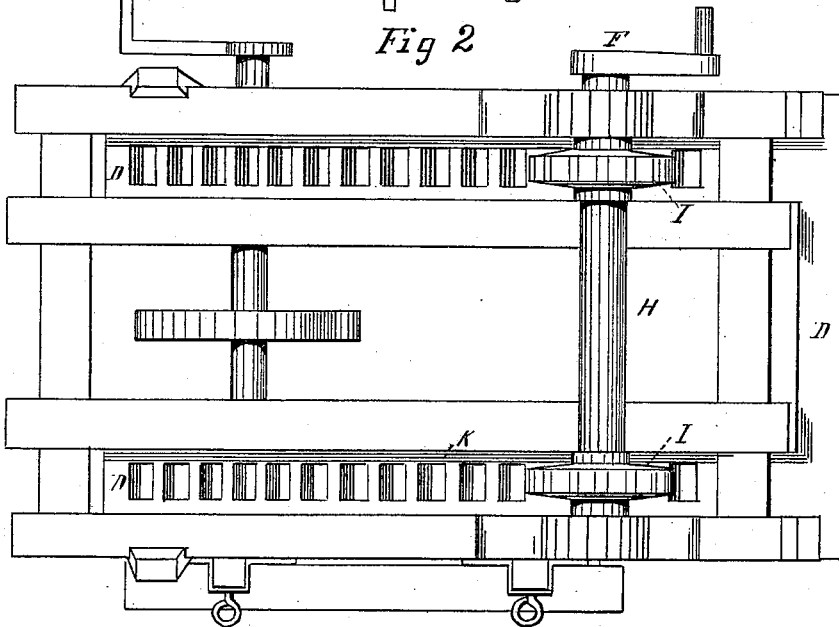

Fig 2



WITNESSES:

B. C. Pole
E. C. Court

INVENTOR.

Samuel S. Forman
and William Conlee

C. S. Whitman per ATTORNEY.

UNITED STATES PATENT OFFICE.

SAMUEL S. FORMAN AND WILLIAM CONLEE, OF MOUNT STERLING, KY.

IMPROVEMENT IN BORING-MACHINES.

Specification forming part of Letters Patent No. **181,662**, dated August 29, 1876; application filed March 24, 1876.

To all whom it may concern:

Be it known that we, SAMUEL S. FORMAN and WILLIAM CONLEE, of Mount Sterling, county of Montgomery and State of Kentucky, have invented an Improvement in Boring-Machines.

The following description, taken in connection with the accompanying plate of drawings, hereinafter referred to, forms a full and exact specification, wherein are set forth the nature and principles of the invention, by which the same may be distinguished from others of a similar class, together with such parts thereof as are claimed as new and are desired to be secured by Letters Patent of the United States.

Our invention relates to that class of boring-machines which are made use of in the manufacture of posts; and the nature thereof consists in certain improvements in the construction of the same, hereinafter shown and described.

In the accompanying plate of drawings, in which corresponding parts are designated by the same letters, Figure 1 is a plan of the top of the machine. Figure 2 is a plan of the under side thereof.

In the said drawings, A designates the auger-shaft, upon which is placed the balance-wheel B. The said shaft is made to rotate upon the friction-wheel C, having their bearings in the carriage D, by means of the crank E. The carriage D is moved to the right or left by means of the crank F, which rotates the shaft H, upon which are pinions I, which engage with racks K upon the bottom of said carriage.

We claim and desire to secure by Letters Patent of the United States—

The combination of the auger-shaft, having a balance-wheel thereon, the friction-rollers, and the carriage upon which the friction-rollers are mounted, as and for the purposes described.

In testimony that we claim the foregoing we have hereunto set our hands this 24th day of December, 1875.

SAMUEL S. FORMAN.
WILLIAM CONLEE.

Witnesses:

G. W. BERKLEY,
JAMES W. WILLS.