

E. HUSON.
HORSE HAY-RAKE.

No. 181,681.

Patented Aug. 29, 1876.

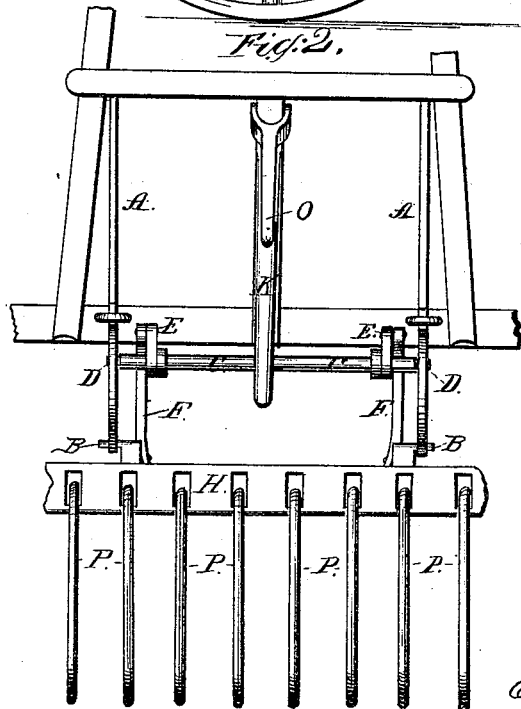
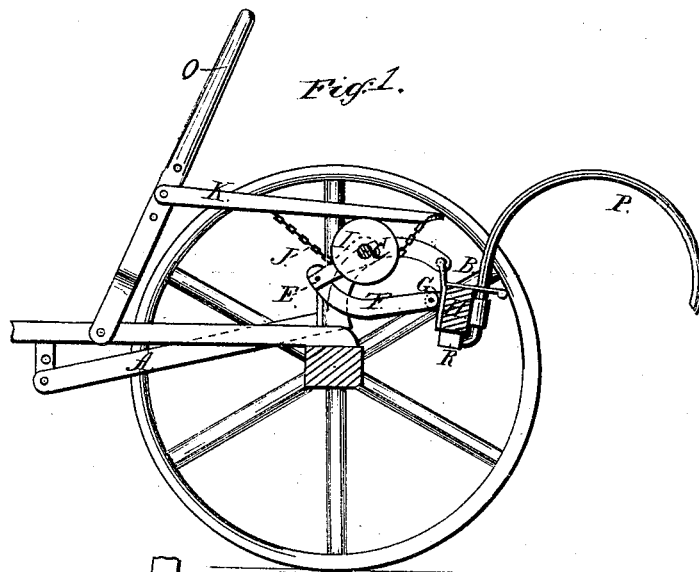

Attest
O. B. Hyde
J. A. McKimsey

Inventor:
Edgar Huson

UNITED STATES PATENT OFFICE.

EDGAR HUSON, OF ITHACA, NEW YORK, ASSIGNOR TO HIMSELF AND
JOHN M. JAMIESON, OF SAME PLACE.

IMPROVEMENT IN HORSE HAY-RAKES.

Specification forming part of Letters Patent No. **181,681**, dated August 29, 1876; application filed
April 25, 1876.

To all whom it may concern:

Be it known that I, EDGAR HUSON, of Ithaca, Tompkins county, New York, have invented an Improvement in Horse-Rakes; and I do hereby declare that the following is a full and exact description thereof, reference being had to the annexed drawings, and to the letters of reference marked thereon.

Figure 1 is a side profile view of my rake, and Fig. 2 parts thereof.

My objects are, first, to relieve the labor of unloading the rake; second, to fix the teeth while raking; third, to prevent side motion to the teeth while raking.

These I accomplish, first, by a long hinge, A, with a joint at each end, one end hinged to any convenient place in front of axle, the other end to the rear of the rake-head, at B B, thus balancing the head and teeth. I then insert shaft C into the hinge A at D. The cranks E E are attached to the head by the connections F F, attached to joint B at G G. The connections F are bent so as to be locked when the cranks are up, by the ends being back of shaft C, as shown by the dotted line; and by a half revolution of the shaft C, the cranks and connections extend and press down on the head.

To the wheel I on shaft C is secured a chain, J, one end of which is attached to the end of bar K, while the other end of the chain is secured to the bar K near its connection with hand-lever O.

The weight of the head H is supported by the hinge A and bar or connecting-rod F, and

the force tending to depress the hinge A is counteracted by the force exerted on rod F, which tends to sustain the hinge A.

By moving the hand-lever O the rake may be adjusted to any desired height, while the rake-teeth, having a positive connection with the axle of the rake, are made to adjust themselves to any inequalities on the surface of the field.

The teeth P are passed through loops or staples in rear of head H. They pass under and up the front side, through oblong eyes or loops, with an elbow or support to prevent their falling out, thus giving them an independent motion.

The use of the devices I have invented is apparent to those skilled in the art to which it appertains.

I claim—

1. The combination, with the hinge A, pivoted in front of the axle, and its rear portion resting on the axle, of the rake-head H, connected with the hinge A by means of the connecting-rods F, shaft C, and pivots B, substantially as and for the purpose specified.

2. The combination, with the hinge A, constructed and arranged as described, the rake-head H, connecting-bars F, and shaft C, of the chain-wheel I, chain J, lever K, and hand-lever O, substantially as and for the purpose specified.

EDGAR HUSON. [L. s.]

In presence of—

O. P. HYDE,
J. H. MCKINNEY.