

W. F. LEOPOLD.
CAR-COUPLING.

No. 181,691.

Patented Aug. 29, 1876.

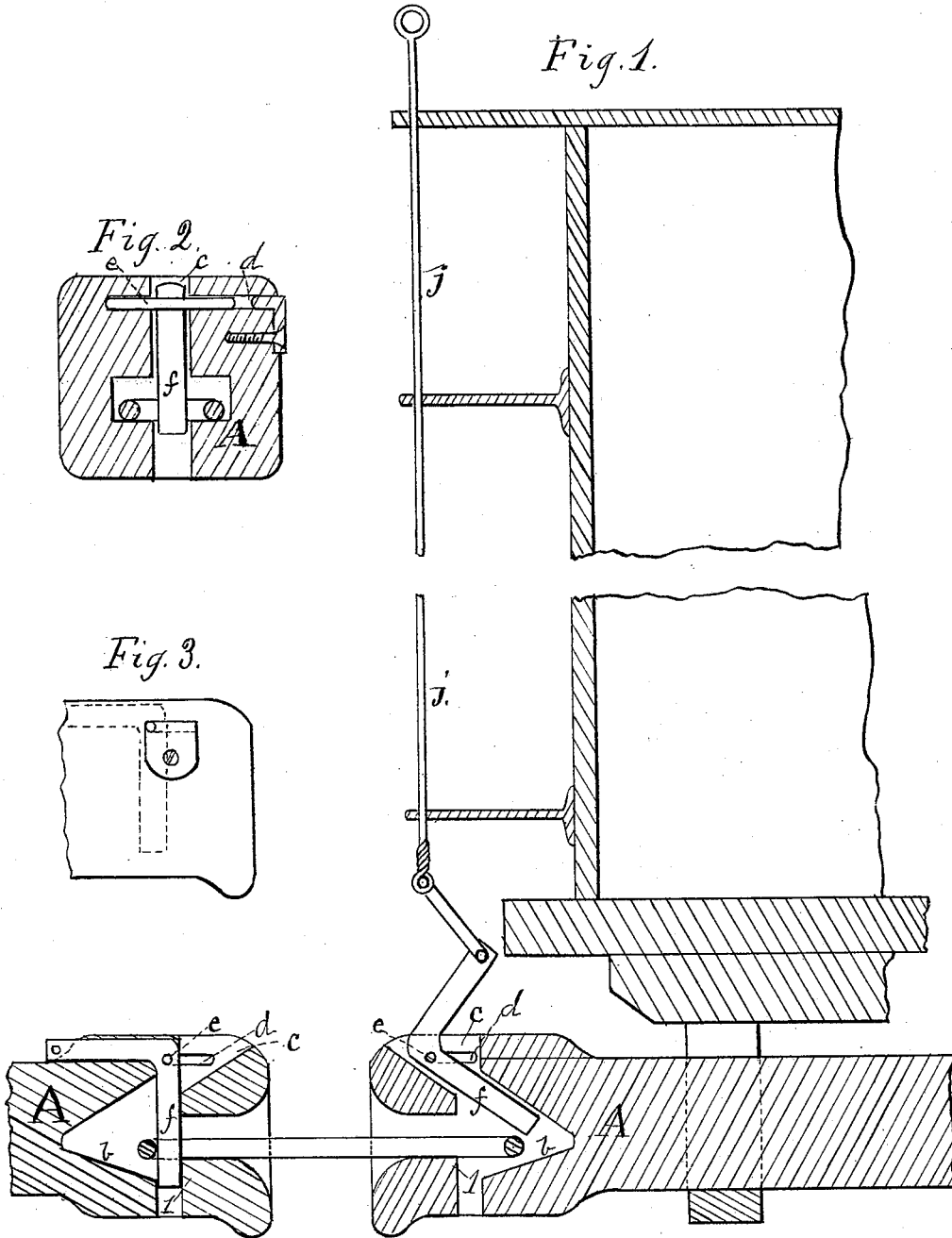

Witnesses
Pennington Halsted
W. R. Edden.

Inventor
William F. Leopold
by John J. Halsted.
att'y

W. F. LEOPOLD.
CAR-COUPLING.

No. 181,691.

Patented Aug. 29, 1876.

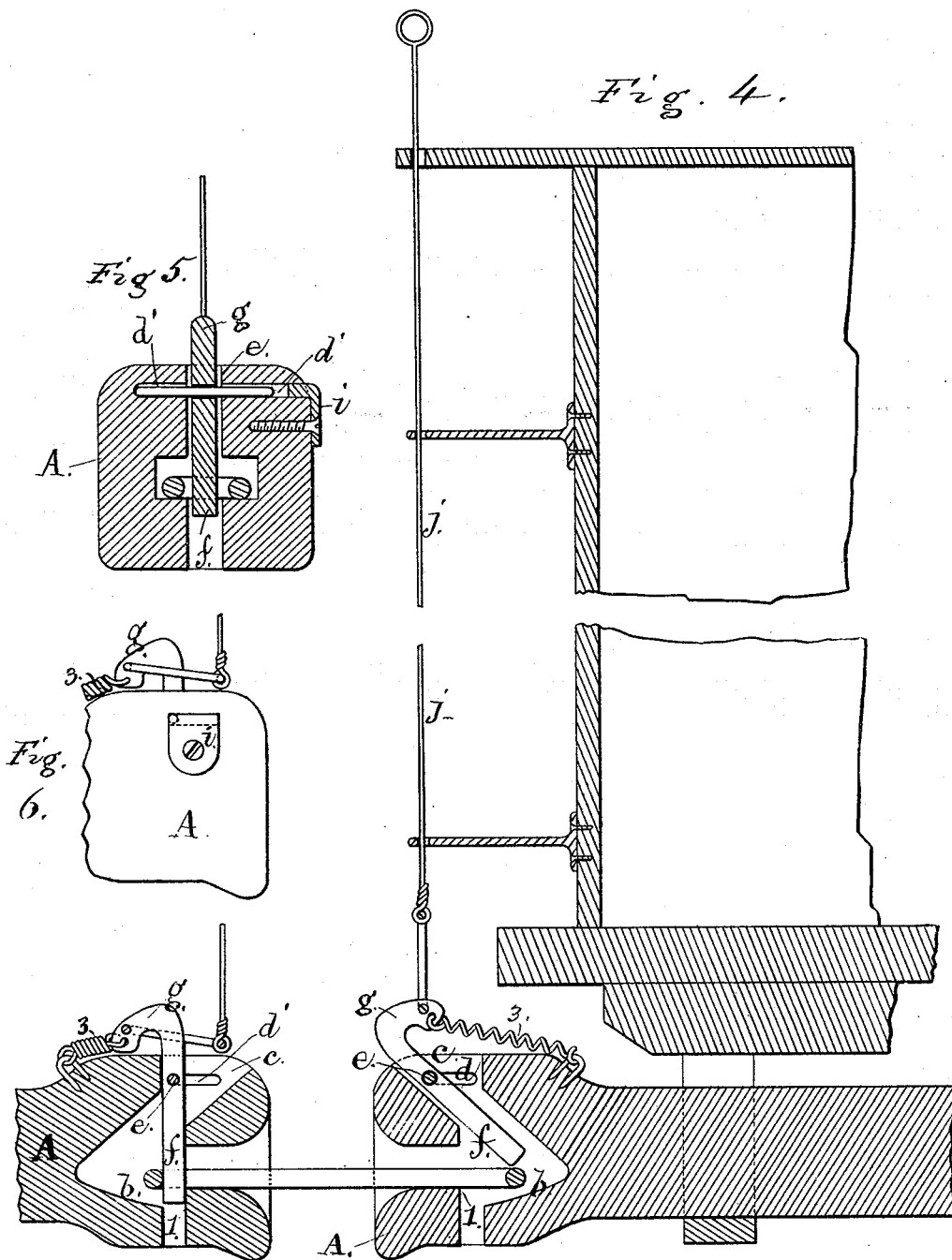

WITNESSES
Villette Anderson.
John Robey, Jr.

INVENTOR
William F. Leopold
by *John J. Halsted*
his Attorney

UNITED STATES PATENT OFFICE.

WILLIAM F. LEOPOLD, OF ST. JOSEPH, MISSOURI, ASSIGNOR OF ONE-HALF HIS RIGHT TO PIERRE LE B. COOMBS, OF SAME PLACE; SAID LEOPOLD AND COOMBS ASSIGNORS OF ONE-THIRD THEIR RIGHT TO LITTLETON R. LANCASTER, OF SAME PLACE.

IMPROVEMENT IN CAR-COUPINGS.

Specification forming part of Letters Patent No. 181,691, dated August 29, 1876; application filed June 17, 1876.

To all whom it may concern:

Be it known that I, WILLIAM F. LEOPOLD, of St. Joseph, in the county of Buchanan and State of Missouri, have invented certain Improvements in Automatic Car-Couplings, which are fully set forth in the following specification, reference being had to the accompanying drawings.

The aim and object of my improvements are to afford a simple, cheap, and effective automatic coupler, which is applicable to the ordinary old style of draw-heads; which will connect or couple with such draw-heads; which will couple, if desired, with the ordinary pin and link; is adapted for passenger, but more especially for freight, cars; may have its draw-head cast in one piece, and may be cast new or altered from ordinary draw-heads at a trifling cost.

In the drawings, Figure 1 is a longitudinal section of my couplers; Fig. 2, a cross-section of one of the draw-heads through the slots and bolt and locking-piece; Fig. 3, a fragmentary side view; Figs. 4, 5, and 6, similar views showing a modification.

The draw-head A is cast substantially of the ordinary size and shape, and having the customary holes above and below, as if to receive the ordinary coupling pin or bolt. It is also provided with a depression, slot, or channel, *b*, in the lower part, and with a depression, slot, or channel, *c*, in the upper part, both being made or cored out in the casting, and for purposes hereinafter stated. It has also other slots *d d'* in the upper part, to receive and support, and also to permit the movement of, a pivot or fulcrum-pin, *e*, on which is hung the swinging coupling-piece *f*, which is made of wrought-iron, and constructed with a weighted or overbalanced top, *g*, having a constant tendency to throw its lower end forward or toward the mouth of the draw-head until it is arrested in its proper vertical position by coming in contact with the vertical end or abutment 1 of the depression *b*. The overbalanced top *g* rests, when unlifted, in a recess or groove, 2, on top of the draw-head, so as to be at least flush with it. It is then always out of the way, and, besides other advantages, if the draw-head plate should break and allow a

draw-head to be pushed forcibly back under the car, the part *g* of pin *f* will be safely out of the way, and cannot strike against the dead wood. The fulcrum-pin *e* is not fixed, but rests in the slots *d d'*, so that it may shift its position. The slot *d* is continuous through the body of the draw-head, but the slot *d'* is not; so that when the pin *e* is in its place, by being inserted through *d* into *d'*, it cannot escape through *d'*, and it is then locked or kept from slipping out from *d* by means of a lock-piece, *i*, which is screwed to the draw-head, its upper end closing the mouth of slot *d*.

To the end of the overbalanced top *g* of the swinging pin or piece *f* a lifting-rod, *j*, and a connecting-link of any suitable kind, are attached, to enable the brakeman, from the platform of passenger or from the roof of freight cars, to uncouple the cars by simply lifting the rod, and thereby throwing backward and upward the lower end of the swing-piece, so as to release from it the coupling-link *k*, which links two cars together.

It will be understood that the lifting-rod runs in staples or guides in the end of the car, and preferably alongside of the rod employed for actuating the brakes.

In coupling, the operation is as follows: The coupling-link *k* being previously arranged in one of the draw-heads in the usual manner, and the cars brought together, the link, upon passing into the draw-head of the next car, pushes back the lower end of the swinging coupling-pin *f* until it has passed beyond it. This pin *f* then returns automatically to its position through the agency of its overbalance. This completes the coupling, and the swing-pin has now two firm bearings or abutments against the solid body of the draw-head—viz., one above and one below its mouth—similar in character and effect to those of the ordinary bolt-and-link couplings; and it will be seen that when the train is in motion there is no strain or pull whatever upon the pivotal or fulcrum pin *e*, as it plays loosely in its slots, and all the strain is sustained by the abutments of the draw-head, against which the link *k* pulls the pin *f*.

In uncoupling, the operation is as follows: The pin *f*, by raising the lifting-rod *j*, is raised

and thrown forward, (the cars having been previously backed enough to throw the link *k* far back into the draw-head,) and then, as the cars separate, the link passes under the end of the pin *f*, and is withdrawn.

In case of any accident occurring to the pin *f*, it may be removed at once by taking out the fulcrum or pivot pin *e* through the lock *i*, after which the apparatus is still available as a complete ordinary coupler, needing only an ordinary coupling-pin, the holes for the same being already provided in the draw-head.

From the above description it will be seen how simply and economically the draw-heads can be cast in a single piece, with the channels and slots therein; that when so cast they are available for use in the ordinary way with the ordinary bolt or pin, while, at the same time, by means of my swing-piece and shifting fulcrum, the whole becomes automatic.

The coupler-piece *f* may be provided with a spiral or other spring, 3, (see Figs. 4, 5, 6, Sheet 2,) to aid in forcing its lower end down after being lifted, and the overbalance *g* may project above the draw-head; but I prefer to make it, as first above described, with its overbalance heavy enough to dispense with any spring, and also sunk in a recess or groove in the draw-head.

I claim—

1. The draw-head, which, while of ordinary general exterior form of construction, and provided with top and bottom holes adapted for an ordinary drop-bolt, is also provided with the channels *c* and *b*, which together compose a continuous channel inclining downward from the front of the draw-head, and adapt the same for a shifting and swinging piece, *f*, as and for the purposes set forth.

2. In combination with the channels *b* and *c*, the horizontal slots *d d'*, adapted to allow an automatic forward and backward movement of the shifting pivot-pin *e*, on which the swinging piece *f* is sustained.

3. The swinging piece *f*, overbalanced on its top at its rearward end, as shown and described, in combination with a horizontally-shifting fulcrum-pin and the reacting spring, substantially as set forth.

4. The combination of the weighted piece *f*, the horizontally and automatically shifting fulcrum-pin *e* and the upper and lower bearings or abutments in the draw-head, serving to relieve the shifting-pin of all drafting strain.

WILLIAM F. LEOPOLD.

Witnesses:

L. R. LANCASTER,
E. J. KNAPP.