

O. B. ROBINSON & J. B. DOSS.
 PENDULUM MOTOR.

No. 181,721.

Patented Aug. 29, 1876.

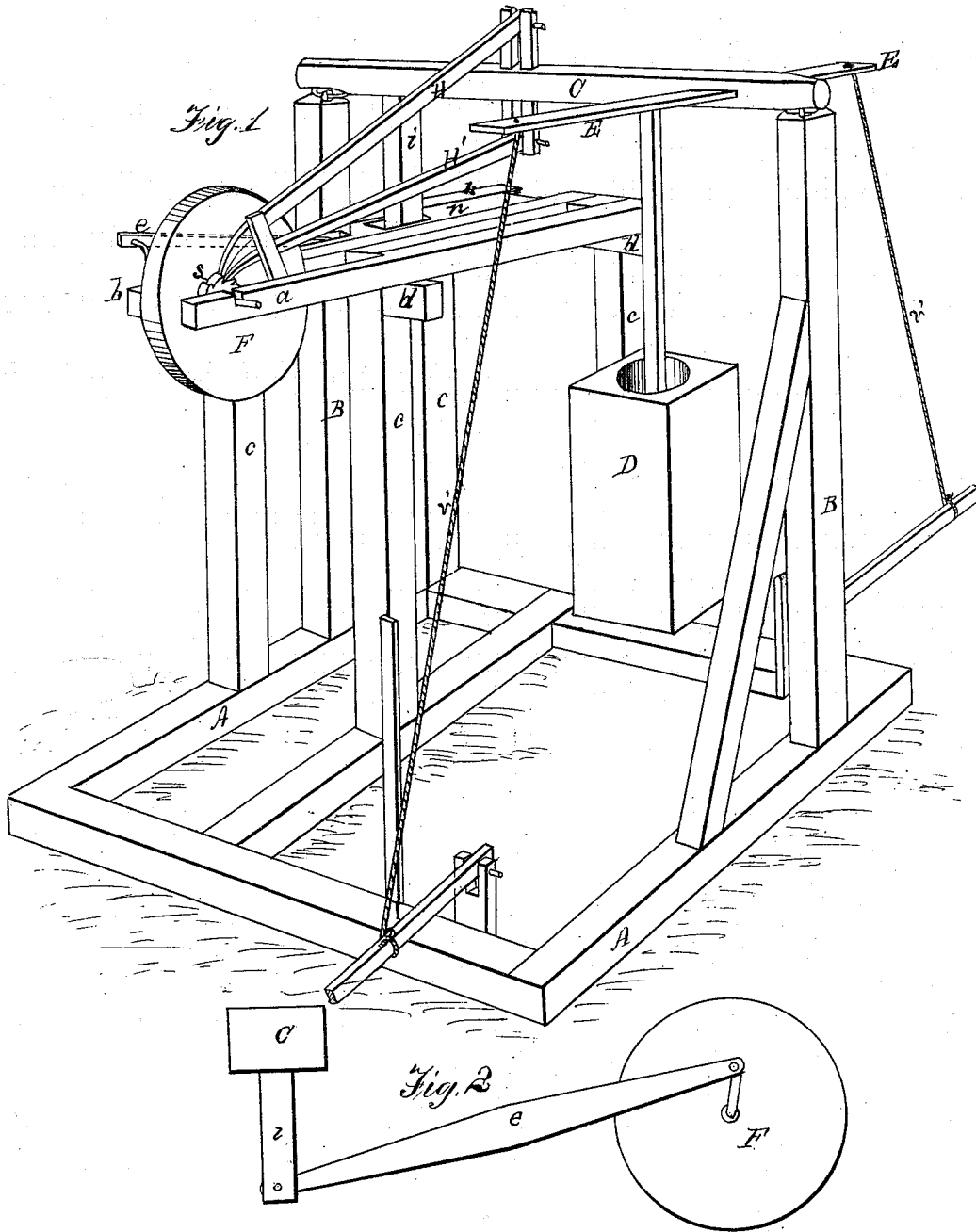

Witnesses
J. C. Turner.
L. A. Luce

Inventors
Oscar B. Robinson
Joel B. Doss
 By, *J. H. Houston atty.*

UNITED STATES PATENT OFFICE.

OSCAR B. ROBINSON AND JOEL B. DOSS, OF CLAYVILLE, KENTUCKY; SAID DOSS ASSIGNOR TO SAID ROBINSON.

IMPROVEMENT IN PENDULUM-MOTORS.

Specification forming part of Letters Patent No. 181,721, dated August 29, 1876; application filed June 24, 1876.

To all whom it may concern :

Be it known that we, OSCAR B. ROBINSON and JOEL B. DOSS, of Clayville, in the county of Webster and State of Kentucky, have invented certain new and useful Improvements in Pendulum-Motors; and we do hereby declare that the following is a full, clear, and exact description thereof, which will enable others skilled in the art to which it appertains to make and use the same, reference being had to the accompanying drawings, and to letters of reference marked thereon, which form a part of this specification.

Similar letters indicate corresponding parts.

The object of our invention is a simple and cheap motive power, to be used for propelling machinery, and whereby the power of man may be rendered equal to that of almost any number of horses.

Figure 1 is a perspective view of our invention. Fig. 2 is a sectional view, showing a modification.

A represents the sills composing the lower part of the frame; B, upright posts; C, horizontal rocking shaft, the ends of which rest upon the uprights B; D, pendulum; E, lever passing through the shaft C, at right angles with it, for the purpose of operating the pendulum; F, band-wheel, which is supported by the frame, consisting of the projecting arms *a* *b*, posts *c*, and cross-timbers *d*. The wheel is connected with the shaft C by a pitman, *e*, slider *n*, and trick-lever *i*; or it may be directly connected with the trick-lever *i* by a long pitman, as shown in Fig. 2. The slider *n* operates between the grooved pieces *b* *k*.

Our machine is designed to operate by means of the vibratory motion of the pendulum, and the amount of power obtained is regulated by the length and weight of the pendulum, the bottom of which is so constructed that any amount of weight may be attached.

It is obvious that the pitman may connect directly with the pendulum-shaft, thereby dispensing entirely with trick-lever *i*.

When it is desired to operate our machine, the pendulum is set in motion by the lever E,

which may be of any desired or convenient length, and which is provided with a rope, V, depending from each end, to each of which the power of one or more men is applied.

It is obvious that when a very heavily-loaded pendulum is used, the principal power required will be in starting the pendulum. This is obtained by means of the additional levers I, which may be multiplied in proportion to the power required. The pendulum being once started, one or more men at each rope will be sufficient to maintain its momentum. The vibrations of the pendulum impart a rocking motion to the shaft C, which causes a reciprocating motion in the lower end of the trick-lever *i*, and thereby imparts motion to the wheel by means of the connections, consisting of the slider *n* and pitman *e*. This motion is also assisted by means of the long and short arms or pawls H H', the first of which is attached to the upper, and the other to the under, side of the shaft C, and their opposite ends made to operate in a ratchet-wheel, *s*, forming part of the wheel F.

It is obvious that the power of our motor may be increased or diminished by lengthening the pendulum and increasing its weight, and the speed of the machinery to be operated by multiplying gearing.

Our motor is designed to supply a power for running mills, pumps, thrashing-machines, or any other kind of machinery, at a comparatively small cost, and where water or wind power is impracticable.

Having thus described our invention, what we claim, and desire to secure by Letters Patent, is—

1. The pendulum D, rocking shaft C, and trick-lever *i*, in combination with the slider *n*, pitman *e*, and wheel F, arranged substantially as described, and for the purpose specified.

2. The combination of the pendulum D, shaft C, pawls H and H', with the wheels F *s*, arranged substantially as described, and for the purpose specified.

3. The combination of the pendulum D and

shaft C with the lever E, ropes *a'*, and levers I, arranged substantially as described, and for the purpose specified.

4. The arrangement of the uprights A, shafts C, pendulum D, levers E and I, trick-lever *i*, slider *n*, pawls H and H', pitman *e*, and wheels F *s*, substantially as described, and for the purpose specified.

In testimony that we claim the foregoing as our own invention we affix our signatures in presence of two witnesses.

OSCAR B. ROBINSON.
JOEL B. DOSS.

Witnesses:

H. W. DAVIS,
J. W. WICKS.