

R. H. SMITH.

STREET SWEEPING MACHINES.

No. 181,735.

Patented Aug. 29, 1876.

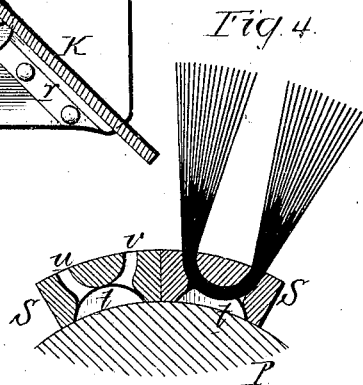
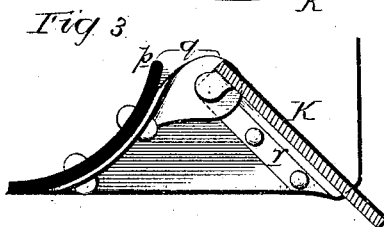
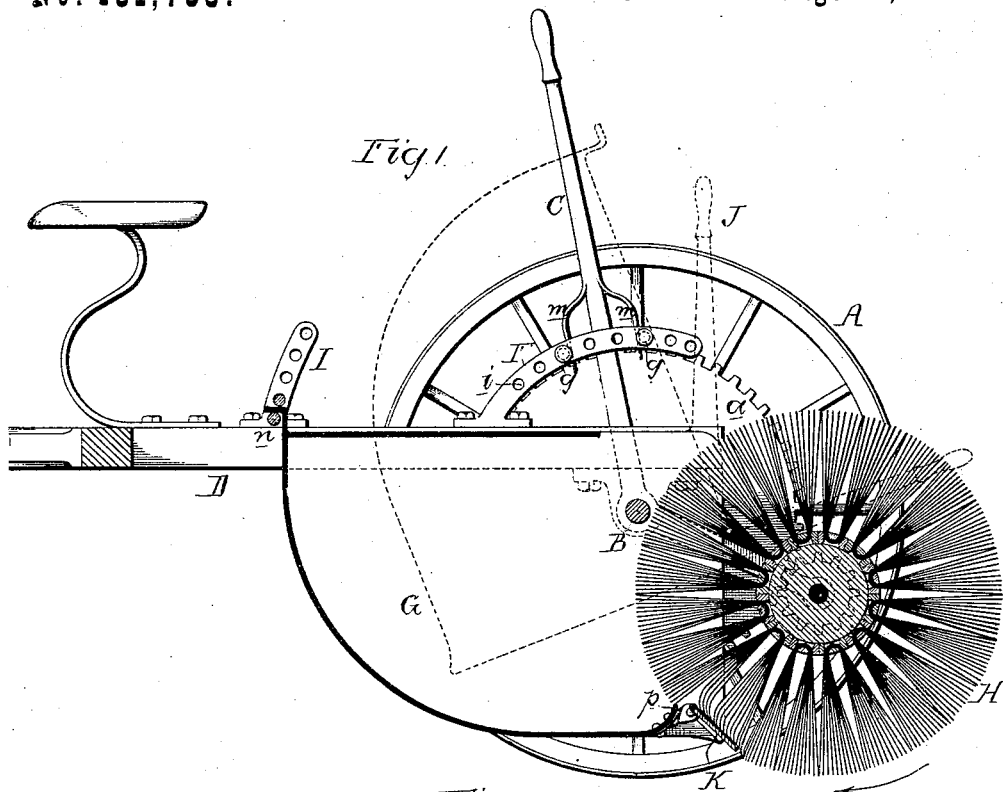

Witnesses
Harry Howson
Harry Smith

Robert H. Smith
 by his Attorneys
Howson and Co.

R. H. SMITH.
STREET SWEEPING MACHINES.

No. 181,735.

Patented Aug. 29, 1876.

Fig 2.

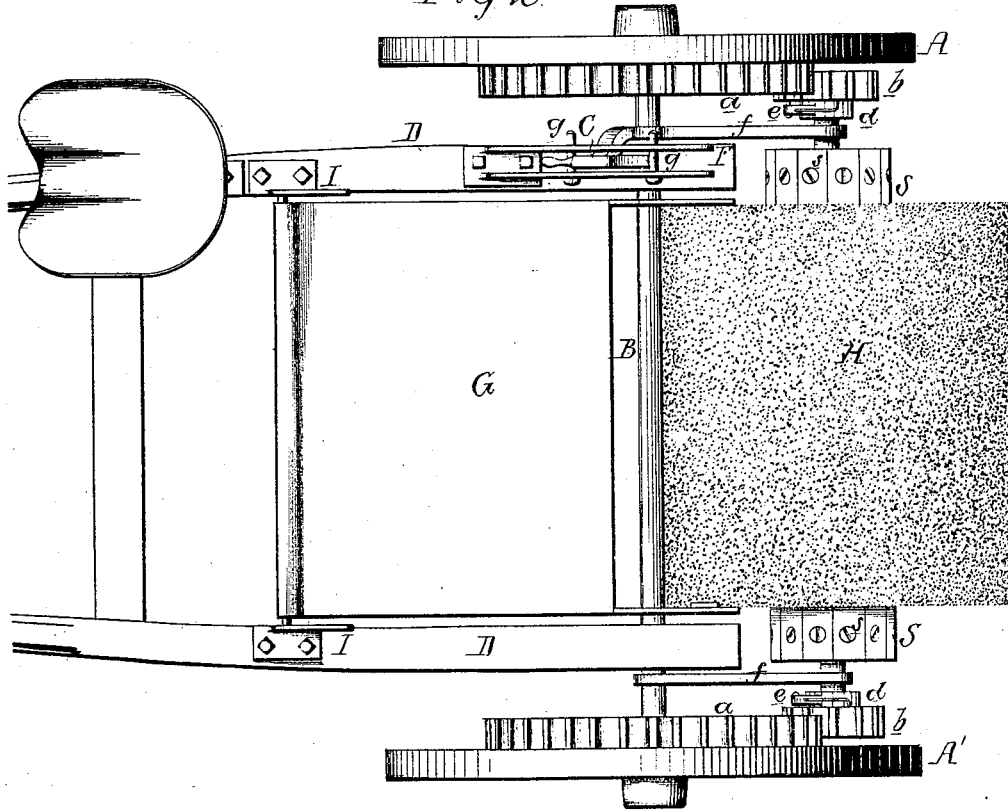

Fig. 5.

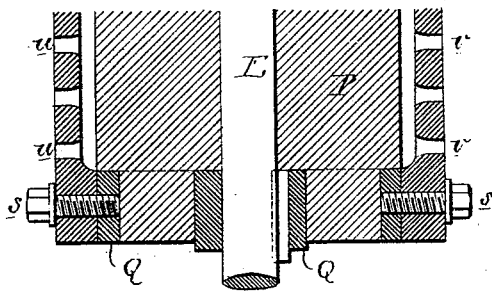
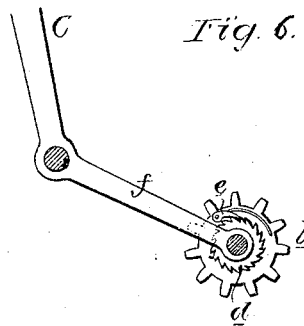

Fig. 6.



Witnesses
Harry Lawson
Harry Smith

Robert H. Smith
by his Attorneys
Howson and Son

UNITED STATES PATENT OFFICE.

ROBERT H. SMITH, OF PHILADELPHIA, PENNSYLVANIA.

IMPROVEMENT IN STREET-SWEEPING MACHINES.

Specification forming part of Letters Patent No. 181,735, dated August 29, 1876; application filed June 12, 1876.

To all whom it may concern:

Be it known that I, ROBERT H. SMITH, of Philadelphia, Pennsylvania, have invented an Improved Street-Sweeping Machine, of which the following is a specification:

The object of my invention is to construct a simple, cheap, and compact machine for sweeping and collecting the dirt from streets, roads, garden-walks, &c., an object which I attain in the following manner:

In the accompanying drawing, Figure 1, Sheet 1, is a vertical section of my improved sweeping-machine: Fig. 2, Sheet 2, a plan view, and Figs. 3, 4, 5, and 6 are detached views, drawn to an enlarged scale, and illustrating different features of my invention.

The machine is mounted upon wheels A A', which are loose on an axle, B, adapted to bearings on the main frame D of the machine, each of the wheels A A' carrying a cog-wheel, *a*, which gears into a pinion, *b*, hung loosely upon the end of the broom-shaft E, motion being imparted to the latter when the machine is drawn through the medium of ratchets *d*, secured one to each end of the broom-shaft, and a spring-pawl, *e*, carried by each pinion *b*. When the pinions turn in the opposite direction, however, they fail to impart motion to the shaft E. This shaft E turns in bearings, in the ends of two arms, *f*, Figs. 2 and 6, which are arranged one at each side of the machine, and are keyed or otherwise secured to the axle B. One of these arms *f* is secured to or forms part of a lever, C, which extends upward to a convenient height, and is retained in any position to which it may be adjusted by pins *g g*, adapted to openings *i* in a segmental plate, F, springs *m m* on the lever bearing against these pins.

G is the receptacle or pan into which the dirt is swept by the broom H, this pan being loosely hung to the axle B and resting at its front end upon a bar, *n*, extending transversely across the machine, and adapted at each end to openings in segmental plates I, secured to the frame D of the machine. The pan G may be tilted and its load discharged by operating an arm, J, secured to one side of the said pan, the accidental tilting of which, however, is prevented by the preponderance of the load in the front portion of the pan. The

lower edge *p* of the said pan is turned up, as seen in Figs. 1 and 3, and to the sides of the pan adjacent to this lower edge is hinged an apron, K, which is held in the inclined position shown by means of ribs *r* secured to the sides of the pan. A space, *q*, intervenes between the upper edge of the apron K and the turned-up end *p* of the pan G, as shown in Fig. 4, for a purpose explained hereafter.

Instead of making the broom by cementing tufts of the broom material into openings in a wooden cylinder, as usual, I construct it in the peculiar manner best observed in Figs. 4 and 5. The wooden cylinder P on the broom-shaft E is mortised at each end, for the reception of a metal spider, Q, Fig. 5, which is keyed on or otherwise secured to said shaft. Around the cylinder P is arranged a number of segmental blocks or slats, S, secured at each end by a bolt, *s*, passing into the spider Q. Each of these slats S has a longitudinal groove, *t*, on its under side, and from this groove a series of openings, *u* and *v*, extend through each slat, for the reception of a wisp of the broom, as shown in Fig. 4, the ends of each wisp projecting beyond the surface of the cylinder, and its central portion being contained within the groove *t*.

The operation of the machine is as follows: On being drawn over the ground, motion in the direction of the arrow, Fig. 1, is imparted to the broom, through the medium of the cog-wheels *a*, pinions *b*, and the pawl-and-ratchet connection described, the dirt being carried by the broom up the inclined apron K and discharged into the pan G, and the dirt being prevented from banking at the top of the apron K, owing to the space *q* between the upper edge of the same and the edge *p* of the pan G, the loose dirt falling through this space and being again swept up by the broom.

The load is dumped at intervals, by operating the arm J, so as to turn the pan G to the position shown in dotted lines, Fig. 1.

The broom will readily yield to any inequalities on the surface which is being swept, owing to the spring-arms *m* on the lever C, and as the broom becomes worn it can be lowered by altering the position of the lever C, or the broom may be raised clear of the ground by operating the same lever. When the broom is

depressed, it becomes necessary to lower the rear end of the pan G also, in order that the apron K may be in the proper position in relation to the broom, and this is effected by raising the bar *n*, so as to elevate the front end of the pan.

In turning the machine on a curve the broom is operated by one wheel only, the opposite wheel remaining stationary or turning backward, the pawl *e* of the pinion *b*, operated by the same, slipping over the ratchet *d* on that end of the broom-shaft.

When the material of which the broom is composed becomes worn out, it can be readily renewed by removing the blocks S and substituting new material for the old, instead of discarding the entire broom-cylinder, as usual.

By hanging the dirt receptacle or pan G, as well as the broom, on the axle B, the construction of the machine is simplified, its cost lessened, and the entire weight brought directly upon the wheels, the proper degree of traction being thereby insured.

I claim as my invention—

1. A street-sweeping machine in which the broom-shaft E has its bearings in, and is combined with, arms *ff* keyed to the axle of the machine, as set forth.

2. The combination of the axle B and the arms *ff*, carrying the broom-shaft, with the lever C and its spring-arms *m*, the segmental plate F, its openings *i*, and pins *g*.

3. A street-sweeping machine in which the dirt receptacle or pan G is hung loosely to the

axle B, and supported at its front end, all substantially as set forth.

4. The combination of the pan G, loosely hung to the axle, with the perforated segmental plates I and the bar *n*.

5. The combination of the pan G, loosely hung to the axle, with the arm J.

6. The combination of the pan G and its rib *r* with the hinged apron K.

7. The combination of the lower edge *b* of the pan G with the apron K, arranged to leave a space, *q*, intervening between the upper edge of the apron and the edge *p* of the pan, as and for the purpose set forth.

8. The combination of the cylinder P with the blocks S, each having a groove, *t*, and openings *u* and *v*, as set forth.

9. The combination of the cylinder P with blocks S, secured to and fitted closely together on the said cylinder, and with bunches of broom material passed through the blocks and retained in place by the cylinder, as set forth.

10. The combination of the shaft E and cylinder P with the spiders Q, keyed to the shaft, embedded in the cylinder, and serving to receive the ends of the bolts which secure the blocks S to the cylinder, as set forth.

In testimony whereof I have signed my name to this specification in the presence of two subscribing witnesses.

ROBERT H. SMITH.

Witnesses:

HARRY HOWSON, Jr.,

HARRY SMITH.