

W. S. OWEN.
CAR-COUPLING.

No. 181,971.

Patented Sept. 5, 1876.

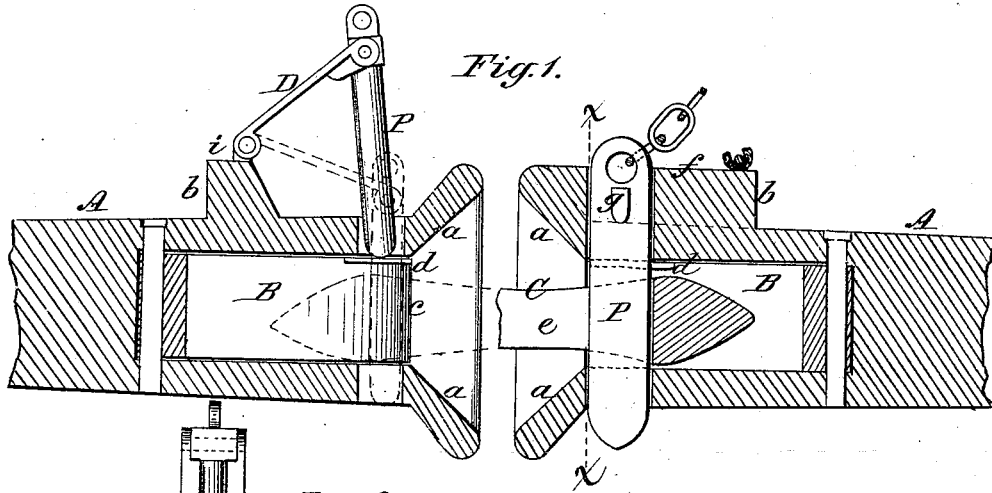

Fig. 1.

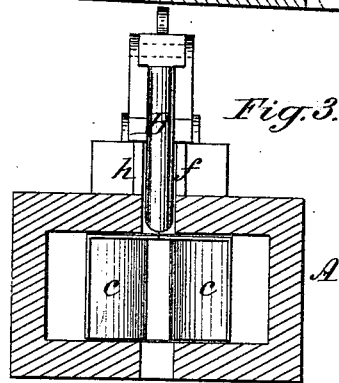

Fig. 3.

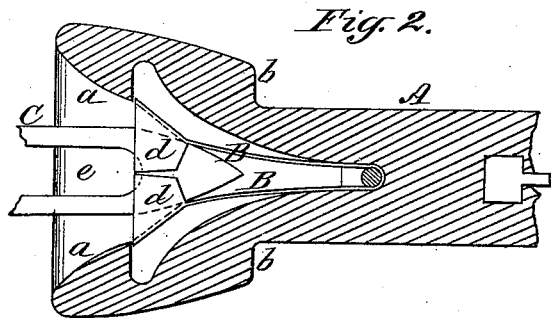

Fig. 2.

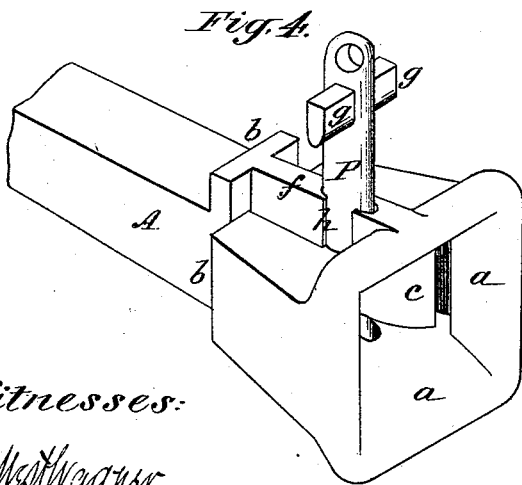

Fig. 4.

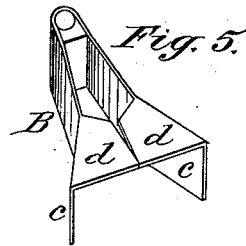

Fig. 5.

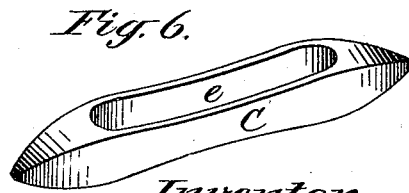

Fig. 6.

Witnesses:

J. M. Wagner.
J. H. Rutherford.

Inventor:

William S. Owen,
by Johnson & Johnson
Attys.

UNITED STATES PATENT OFFICE.

WILLIAM S. OWEN, OF OSKALOOSA, IOWA.

IMPROVEMENT IN CAR-COUPINGS.

Specification forming part of Letters Patent No. 181,971, dated September 5, 1876; application filed August 30, 1876.

To all whom it may concern:

Be it known that I, WILLIAM S. OWEN, of Oskaloosa, in the county of Mahaska and State of Iowa, have invented certain new and useful Improvements in Coupling for Railway-Cars, of which the following is a specification:

My improvement relates to that class of couplings in which the coupling-pin is held in position for automatic coupling by the cars. The draw-head of each car has a flaring mouth, and I arrange within, and just back of, said mouth a bent spring, having flaring ends coinciding with the flaring sides of the draw-head, and provided each with a top plate, which close together and form a support for the coupling-pin, so that upon the entrance of the coupling-link as the cars come together the beveled or inclined sides of the link will strike the flaring ends of the spring, and open their top plates, thus letting the pin fall and effect the coupling. The spring thus serves only to support the pin and effect its descent. When coupled, however, the spring presses against each side of the coupling-link, and prevents all rattling. The coupling-pin I prefer to make of oval form in cross-section, and combine therewith a raised guide on the draw-head, the opening in which corresponds with the form of the pin. This pin may also be provided with a cross-head to enter a cross-notch in the raised guide, and serve to keep the oval of the pin in line with the coupling. By this construction the pin, when raised, is not only held secure in its guide, but is braced against exerting lateral strain upon the draw-head, which the oval form might tend to do. The oval form gives the pin greater strength, prevents it bending, and insures its ready descent within its guide. A chain is used to uncouple the pin, and, if desired, the latter may be connected to the draw-head by a hinged plate to hold it in coupling position.

In the accompanying drawings, Figure 1 represents a vertical sectional view of two draw-heads coupled with my improved coupling; Fig. 2, a horizontal section of one of the draw-heads, taken above the top plates of the spring; Fig. 3, a cross-section at the line *x x* of Fig. 1; Fig. 4, a perspective of one of the draw-heads with the coupling-pin held up;

Fig. 5, the bent spring detached, and Fig. 6 the coupling-link.

The draw-heads A have flaring mouths *a*, and shoulders *b* to fit solidly against the frame of the car. Each draw-head has an interior opening, within which a bent spring, B, is secured by a pin driven through its inner end. Its front ends *c* are made flaring to coincide with the flaring sides *a* of the draw-head, and they form a continuation of said flaring sides back of the coupling-pin. The flaring ends of the bent spring form a flaring mouth to receive the action of the coupling-link C, and they are provided with cap-plates *d*, which, when the pin is raised, close together horizontally, and form its support to hold it up, and upon the opening of the flaring spring ends *c* by the entrance of the coupling-link these plates *d* open and free the way for the descent of the pin. These spring-cap plates *d* lie at the top of the flaring mouth, so that they cannot be struck by the coupling-link. The space within the draw-head is sufficient to allow the spring ends free to open to separate their cap-plates, and the tendency of the ends of the bent springs being constantly to close their cap-plates. These plates are thereby always in position to support the pin when the latter is raised to uncouple the cars. The coupling-link C has a slot, *e*, for the pin, and its ends are inclined on four sides, so as to enter the draw-head in any direction, and the flaring ends of the bent spring stand just inside the flaring sides of the draw-head, so as to be out of the way of the entering coupling-link.

The coupling-pin enters the slot *e* of the link, the inclined sides of which strike and open the flaring sides of the bent spring and separate its cap-plates. In the coupled position of the link the pin stands between the cap-plates, and the sides of the spring back of the pin bear upon and clamp the end of the link and hold it from rattling, and at the same time allow the link to play laterally with the movement of the cars. Many devices have been contrived to hold the pin in coupling position and let it fall upon the entrance of the link; but I know of none in which the opening and closing of a flaring-mouthed spring is made to open and close cap-plates which form a part

of such spring, and in which the spring serves to grasp and hold the link back of the coupling-pin. When coupled the pin is relieved from any pressure of the spring cap-plates, as the link will hold them open until the cars are uncoupled. Although the spring bears upon the inclined sides of the link, yet it can be easily drawn out when the cars are being uncoupled, as the tendency of the spring upon its beveled end is to push it out.

The coupling-pin P I prefer to make oval in cross-section to give it greater strength, prevent it from being bent, and to hold its oval in line with the coupling, the pin opening in the draw-head being of corresponding form. A raised rib-guide, *f*, is cast on the upper side of the draw-head to form a better hold to keep the pin in coupling position, and in connection with this guide the pin has a cross-head, *g*, which fits into a cross-notch, *h*, in the raised guide, and forms a brace to the pin as well as to guide the pin in its descent, and relieve the draw-head from any lateral strain which the oval form of the coupling-pin might produce. Instead of the raised guide, the coupling-pin may be connected at its upper end by a hinge-joint to a plate, D, having its rear end hinged to a projection, *i*, of the draw-head to hold the pin secure in its uncoupled position. The uncoupling is effected by the usual chain-connection with the pin. The gripping action of the bent spring holds the link in a horizontal position in the draw-head ready to enter the coupling-car, whether it be higher or lower than the one carrying the link. The draw-heads are provided with the use of connections, and may have bumper-springs.

The old form of coupling-link may be used when needed, and I may also use a bent coupling-link for high and low cars.

The bent spring serves to hold the coupling-link in a straight line for coupling, and acts as a cushion to said link.

I claim—

1. In a coupling for railway-cars, the bent spring arranged in the draw-head, having flaring ends coincident with the flaring sides of the draw-head and cap-plates, which open and close laterally with the spring to support the pin in coupling position, and to open for its descent by the entrance of the coupling-link to effect the coupling.

2. The combination, with the coupling-link and the coupling-pin, of the bent spring, having flaring ends *c*, and laterally opening and closing cap-plates *d*, as and for the purpose herein set forth.

3. The coupling-pin, of oval form, in cross-section, in combination with a raised guide-way, *f*, of corresponding form, as and for the purpose herein set forth.

4. The combination, with the coupling-pin P, provided with the cross-head *g*, of a raised guide, *f*, on the draw-head, provided with the cross-notch *h*, as and for the purpose herein set forth.

In testimony whereof I have affixed my signature in the presence of two witnesses.

WILLIAM S. OWEN.

Witnesses:

A. E. H. JOHNSON,

J. W. HAMILTON JOHNSON.