

C. MCGINNISS.
MIDLINGS PURIFIERS.

No. 182,028.

Patented Sept. 12, 1876.

FIG. 11.

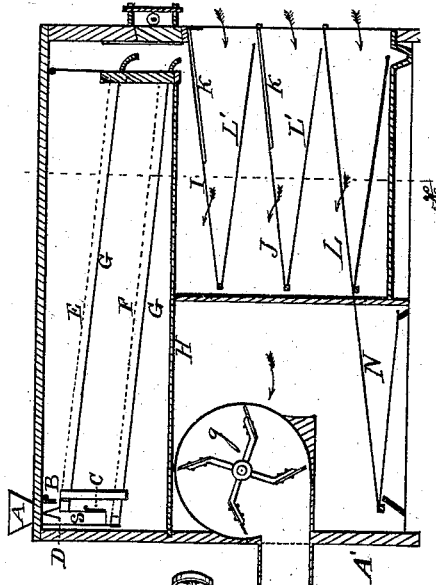
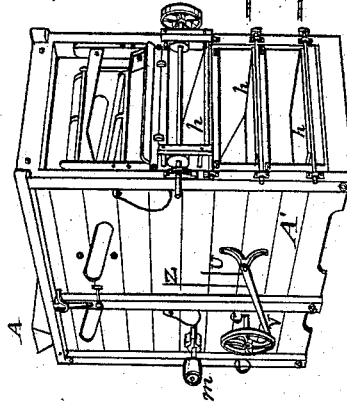

FIG. 1.



WITNESSES

John N. Elliott,
O. H. Adix

INVENTOR.

Cornelius McGinniss
By J. D. Chapin, Atty.

C. MCGINNISS.
MIDLINGS PURIFIERS.

No. 182,028.

Patented Sept. 12, 1876.

FIG. III.

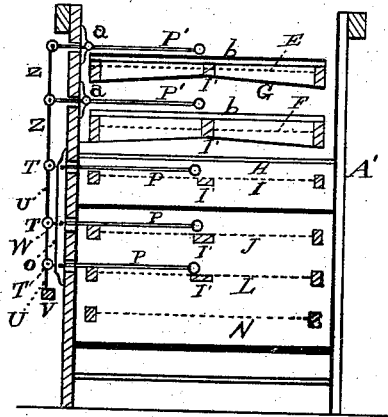

FIG. IV.

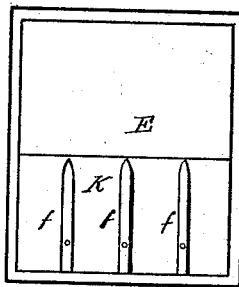
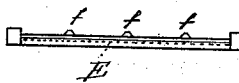

FIG. V.



WITNESSES

John H. Elliott,
O. H. Adair.

INVENTOR

Cornelius McGinniss
By G. A. Chapin, Atty.

UNITED STATES PATENT OFFICE.

CORNELIUS MCGINNISS, OF CHICAGO, ILLINOIS.

IMPROVEMENT IN MIDDINGS-PURIFIERS.

Specification forming part of Letters Patent No. 182,028, dated September 12, 1876; application filed June 23, 1876.

To all whom it may concern:

Be it known that I, CORNELIUS MCGINNISS, of Chicago, in the county of Cook and State of Illinois, have invented a new and useful Improvement in Middlings-Purifiers, of which the following is a specification:

The nature of the present invention consists, first, in feeding devices whereby middlings may be conducted to two or more sets of bolt-riddles; second, in the novel construction of the vibrators, which alternately strike the riddles and keep them free; third, in division-strips placed on the riddles, by means of which middlings are properly divided and prevented from accumulating in heaps in their separation, as the whole is hereafter fully described and shown.

In the drawings, Figure 1 is a perspective representation of a middlings separator or purifier, embodying a part of my improvement. Fig. 2 is a longitudinal section thereof; Fig. 3, Sheet 2, a transverse section of the purifier, taken on line *x*, Fig. 1; Fig. 4, Sheet 2, a plan or top view of one of the riddles removed; Fig. 5, a transverse section of the riddles, taken on the separating-strips.

A' represents the frame of the purifier, which may be of any form convenient for supporting the separating devices, and of a size corresponding to the requirements of the middlings to be separated. *E F* represent the upper riddles, which are made of bolting-cloth, and housed by metal plates *G* underneath. The lower riddles *I J L N* incline toward the front or fan of the purifier, and are made of the same material. Between these riddles are placed chute-boards *L'*, for conducting the stuff from one riddle to the next below.

I do not claim anything new in the arrangement of these riddles, or in their use, as they are common in such purifiers. I give this description to enable others to understand how my improvement operates with them.

P' P' represent agitators, which are weighted at their ends, and are pivoted to bridges *a a*, secured to the side of the purifier. Their outer ends are pivoted to a connecting-rod *Z*, Figs. 1 and 3, which is attached to a vibrat-

ing lever, *V*, Fig. 1. *P P P* represent lower agitators, which are constructed on the same plan as those shown at *P'*, and their outer ends are pivoted to a connecting-rod, *U*, which is also fastened to the vibrating lever *V*, and they are pivoted to a bridge, *O*, attached to the outside of the purifier. The sets of knockers *P P P' P'*, therefore, give blows of different forces, being delivered from different distances, and it is apparent that the rods *Z* and *U* may be connected to the lever *V*, so as to regulate the relative force of these blows, as may be required by the several sets of bolts, the lower bolts requiring less jarring to keep them clear than the upper ones, which receive the coarser portions of the middlings.

The vibrating lever *V* is pivoted to the purifier, and its outer end is brought down by means of a cam or trip-wheel *e c*, Fig. 1, and brings the connecting-rods *Z U* down with it, and, consequently, raises the weighted ends of the agitators *P P'*. When the trip-wheel releases the lever *V*, the agitators fall by their gravity on the bars *I'* of the riddles, and thus keep the latter in motion from above, and prevent the accumulation of middlings more at one point than at another. The trip-wheel is to be driven by a band running from a wheel or pulley, *m*, on the shaft of the fan *g*. The fan may be driven by any means convenient.

The feed-hopper is shown at *A*, and beneath it is placed an Λ -shaped cut-off, *D*, Fig. 1, whereby middlings are in part fed to a riddle, *E*, and part to riddle *F*, the middlings to feed the riddle *F* passing through a spout, *S*. The supply of middlings to the riddles is regulated by sliding valves *B C*, of any ordinary construction, which remain stationary when adjusted. By this means two riddles are fed from one hopper, and may have turned onto them, respectively, more or less middlings, as may be desired, in the purifying process.

fff represent division-strips pivoted to the riddles, for the purpose of giving any desired direction to the middlings in their passage through the purifier. By this means middlings are delivered evenly from the riddle above to those below.

Strips *f* are only shown on the ends of one riddle; but in practice all the riddles are to be provided with them.

I claim and desire to secure by Letters Patent—

1. The feed - hooper A, provided with the inverted V-shaped cut-off D, in combination with the feed - valves B C and riddles E F, as set forth.

2. The combination of the riddles E F I J L N with the agitators P' P' P P P, operated in sets by the rods Z U, vibrating lever V, and trip-wheel *c e*, as and for the purpose specified.

CORNELIUS MCGINNISS.

Witnesses:

G. L. CHAPIN,

O. H. ADIX.