

P. HENNERT.
ELEVATOR.

No. 182,070.

Patented Sept. 12, 1876.

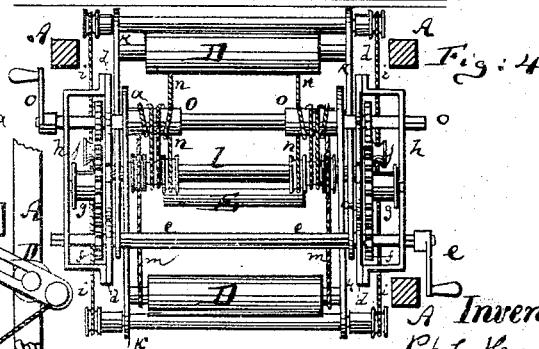
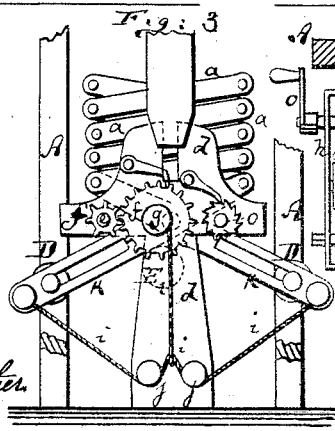
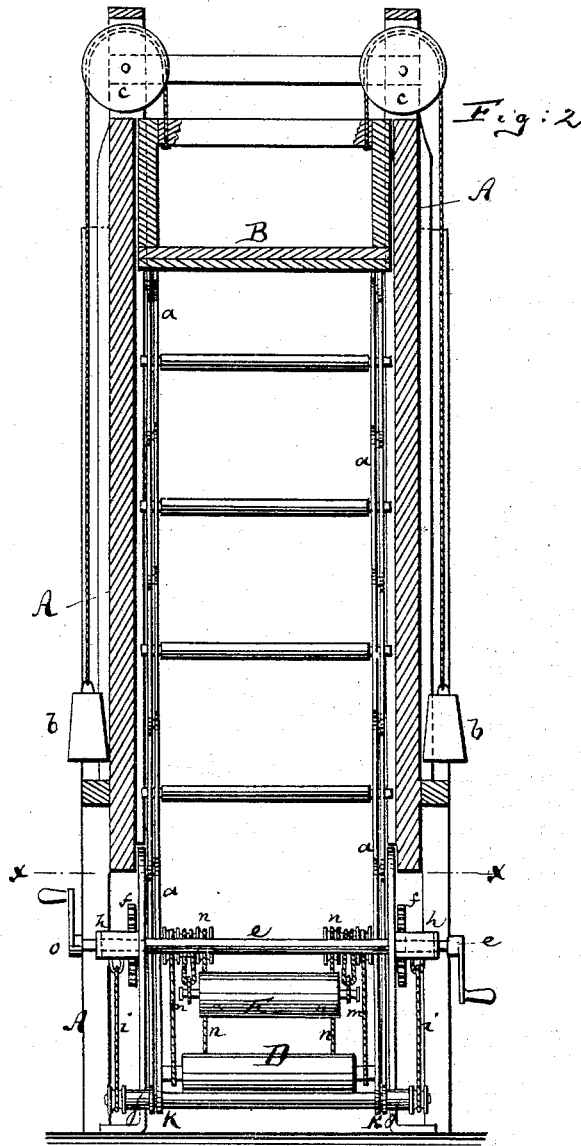
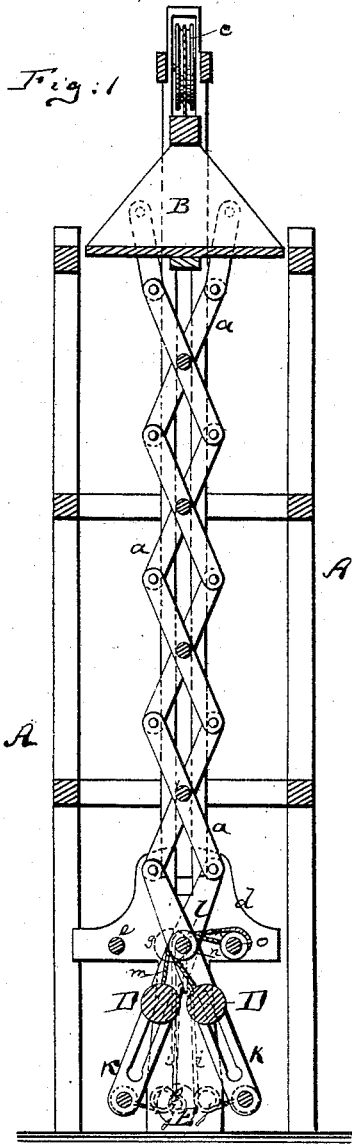

Witnesses:
A. Moraga.
H. A. Gunther.

A. Hennert
Inventor
Phot. Hennert
by his attorney
O. B. Briesen

UNITED STATES PATENT OFFICE.

PHILIP HENNERT, OF NEW YORK, N. Y.

IMPROVEMENT IN ELEVATORS.

Specification forming part of Letters Patent No. 182,070, dated September 12, 1876; application filed August 24, 1876.

To all whom it may concern:

Be it known that I, PHILIP HENNERT, of New York city, in the county and State of New York, have invented a new and Improved Elevator, of which the following is a specification:

Figure 1 is a vertical transverse section of my improved elevator. Fig. 2 is a vertical longitudinal section thereof. Fig. 3 is a side view of the lower portion thereof; and Fig. 4, a horizontal section on the line *x x*, Fig. 1.

Similar letters of reference indicate corresponding parts in all the figures.

This invention relates to an improved elevator of the kind that is supported and operated by lazy-tongs, and has for its object to facilitate the manipulation of the apparatus and accelerate its motion.

The invention consists, principally, in weighting the lower pair of the levers of the lazy-tongs, so that such levers will have the tendency, when the elevator is in its contracted position, to raise it into a vertical position and to extend the lazy-tongs.

The invention also consists in means for removing the weights from, or adjusting them on, said levers when the elevator is to be lowered, and in other details of invention hereinafter more fully pointed out.

In the drawing, the letter A represents the frame of my improved elevator, in which the platform or cage B travels up and down. *a a* are two sets of lazy-tongs that support the cage B at their upper ends, while they are with their lower ends connected with the operating mechanism hereinafter described: The cage B is or may be balanced by a pair of weights, *b b*, that are suspended from it by ropes that pass over friction-rollers *c c* at the upper part of the frame A, as clearly shown in Fig. 2. To the base of the frame A are secured a pair of uprights or standards, *d d*, in which are hung the ends of a crank-shaft, *e*, as shown. This crank-shaft engages, by suitable gearing *f f*, with two winding-drums, *g g*, that are, respectively, hung between the standards *d* and braces *h h* attached to said standards. Around each of the drums *g g* is wound a pair of ropes or chains, *i*, that pass from said drums down over rollers *j j* at the lower parts of the standards, and thence connect, respect-

ively, with the ends of the lowermost levers K K of the two sets of lazy-tongs *a a*, said levers being pivoted and held in place by a fixed pin or shaft, *l*, that is supported by the standards *d*. By revolving the crank-shaft *e* in one direction, and thereby turning the drums *g g*, the ropes or chains *i i* will be wound upon such drums, and the ends of the levers K K of each set of lazy-tongs will be drawn nearer together. This will cause the lazy-tongs *a a* to rise and to lift the cage B.

In order to facilitate this operation, and to adapt the elevator to the raising of heavy loads with but a comparatively small power, I have devised the means now to be described, which aid in drawing the ends of the levers K K of each set of lazy-tongs together.

The lower arm of each of the levers K K—that is, that portion below the pivot *l*—is made longer than the upper arm above said pivot, and is slotted lengthwise, as shown in Fig. 1. These slots receive the journals or gudgeons of two heavy blocks or cylinders, D D, as shown. The weights D are, by suitable chains or ropes *m* that pass over grooved rollers *n n*, connected with a crank-shaft, *o*, which is hung with its ends in the standards *d d*, as clearly shown in Fig. 4. A pawl pivoted to the standard can be used to lock into a pinion on the shaft *o*, and to lock said crank-shaft *o*, if desired, to prevent its further revolution, as indicated in Fig. 3. The weighted cylinders D will, under ordinary circumstances, rest with their journals or gudgeons in the lower parts of the slots of the levers K, but when the crank-shaft *o* is revolved they will be drawn upward, and can then be held suspended in any desired position by locking the crank-shaft *o*. With the shaft *o* is also connected, by ropes or chains, a weight, E, which is suspended vertically from said shaft, and is, more or less, equal in weight to the two cylinders or blocks D, so it will balance them while they are being raised. The weight E will thus render it easy to raise the weights D, as in Fig. 1, for it descends while they ascend. Yet when the weights D are to affect the lazy-tongs the weight E can at once be neutralized by locking the shaft *o* with the pawl and ratchet. It is evident that when the elevator is lowered the lower arms of the levers K K are swung

apart, carrying the weights D with them, unless said weights are held fast by locking the shaft *o* with pawl and ratchet. When the elevator is to be raised, and the crank-shaft *e* is consequently revolved, the weights DD, resting in the lower ends of the slots in levers K, as in Fig. 3, will aid in drawing the lower arms of levers K K downward into a nearly vertical position, and will thus aid in extending the lazy-tongs *a a* and in raising the cage. Thus, by the application of but a comparatively small additional power to the crank-shaft *d* the platform B will be raised by the aid of the weights D. By raising the weights D D, which is done by winding the ropes *m* upon the crank-shaft *o*, their power of contracting the tongs will be diminished in inverse proportion to their distance from the pivot *l* of the levers K. The elevator can, therefore, be adjusted to raise loads of different weight when but the same operative force is employed.

When the elevator is to be lowered, the weights D should be so adjusted as to counterbalance the load to be taken down, and if the elevator is to be lowered without carrying any load they should be raised and locked to their uppermost position. It has already been shown that, and how, the counter-weight E facilitates the elevation of the weight D preparatory to the lowering of the cage. The

lowering of the cage B may be effected by means of a crank-shaft that winds a rope which is attached to the cage, or in any other suitable manner. The cage B may be arrested at any desired height in the frame A by means of a pawl-and-ratchet attachment to the crank-shaft *e*.

I claim as my invention—

1. The combination, in an elevator, of the lazy-tongs *a a* with a weight, D, that is applied to the lower pair of levers constituting the lazy-tongs, substantially as and for the purpose set forth.

2. In a lazy-tongs elevator, the levers K K, made with slots, and combined with the weights D that are adjustable in said slots, substantially as specified.

3. The combination of the slotted levers K with the weights D, shaft *l*, rope *m*, and crank-shaft *o*, substantially as and for the purpose specified.

4. In combination with the weighted arms K of a lazy-tongs, and with the weights D thereto applied, the counter-weight E, and shaft *o*, all arranged to operate substantially as herein shown and described.

PHILIP HENNERT.

Witnesses:

A. V. BRIESEN,
ERNEST C. WEBB.