

A. & L. SMITH & A. SMITH, Jr.

RENDERING APPARATUS.

No. 182,084.

Patented Sept. 12, 1876.

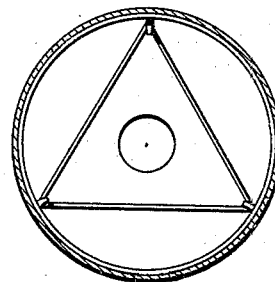
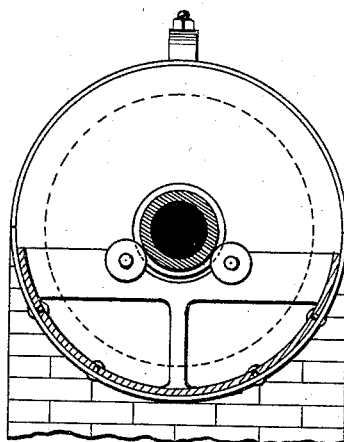
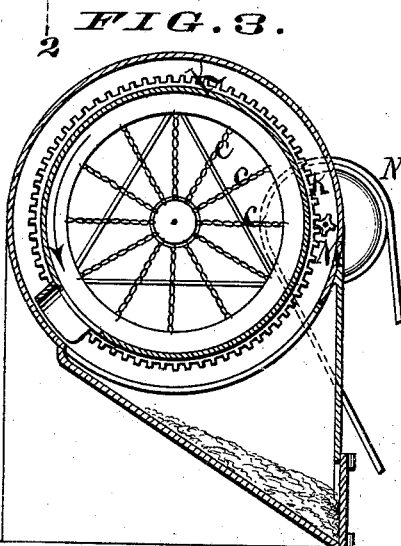
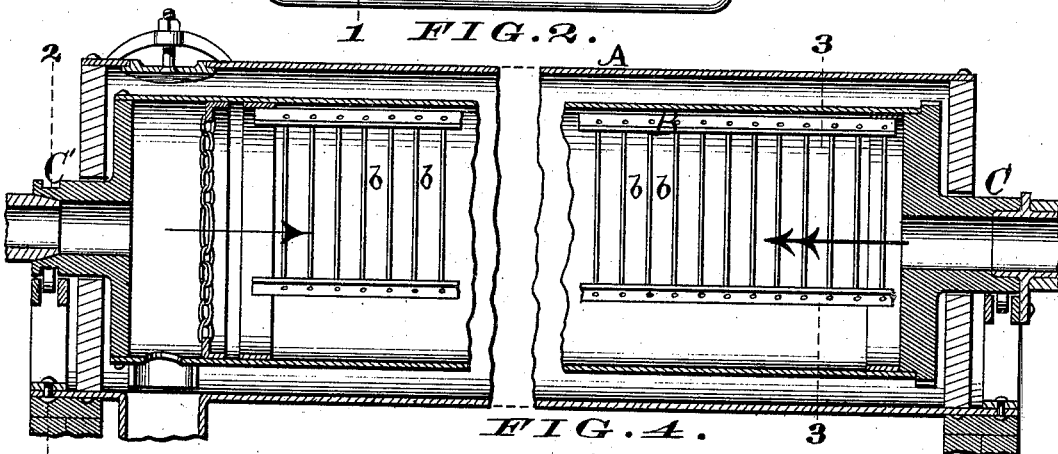
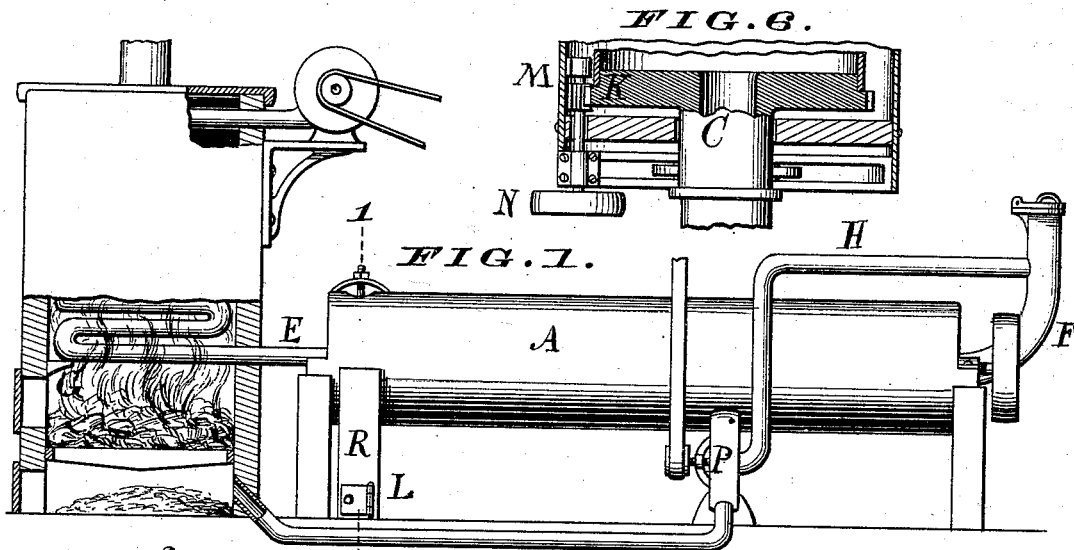

Attest.
Geo. H. Lammiman,
Deputy Register

Amos Smith
Leander Smith
Amos Smith, Jr.
G. Hatch & Partners
Attys.

UNITED STATES PATENT OFFICE.

AMOR SMITH, LEANDER SMITH, AND AMOR SMITH, JR., OF CINCINNATI,
OHIO.

IMPROVEMENT IN RENDERING APPARATUS.

Specification forming part of Letters Patent No. 182,084, dated September 12, 1876; application filed
May 29, 1876.

To all whom it may concern:

Be it known that we, AMOR SMITH, LEANDER SMITH, and AMOR SMITH, JR., of Cincinnati, in Hamilton county, Ohio, have invented certain Improvements for Rendering Fatty Animal Matter, of which the following is a specification:

Our invention relates to the construction, arrangement, and mode of operation of an apparatus for rendering all kinds of fatty animal matter, including fish, for the production of lard, grease, oil, or tallow; and consists in certain improvements in the machinery and mode of rendering described in Letters Patent No. 99,252, granted Amor Smith, January 25, 1870, for "improvement in apparatus for rendering fatty animal matter." It is adapted to use where hot air is the agent employed for rendering.

A represents an outer cylinder or jacket, within which is placed the cylindrical tank B, supported upon bearings C C', or otherwise, so as to be easily revolved. The pipe E enters this tank at one end, and serves to carry the blast of hot air from the furnace G to the interior of the tank. This pressure blast may be operated, as shown in the patent granted Amor Smith, January 25, 1870, or by any other suitable means. The feed-pipe F enters the tank also at one end, and serves to convey the material to be reduced to the tank while the machine is in operation, where it is brought into contact with the hot air. The interior of the tank is provided with bars or chains *b b c c*, as shown in Figs. 2, 3, and 5, so arranged as to divide and agitate the fatty matter, and, by exposing it more thoroughly to the action of the hot air, facilitate the rendering process. H is a pipe connecting with the tank, preferably through the feed-pipe F, so as to convey from the tank the air which has entered through the hot-air pipe E, together with any offensive gases that may be generated during the rendering operation.

The exhaust-fan P, applied to this exhaust-pipe, may be used to increase the draft through it to such an extent as may be neces-

sary in order to prevent the escape of offensive gases through the man-hole or other opening in the tank. By this means, also, the hot air may be drawn more rapidly through the tank and prevent any pressure upon its walls.

The exhaust-pipe may be carried to the furnace, as shown, and therein discharged.

The tank is provided with a man-hole, through which the oil or melted fat, as well as the refuse matter, may be discharged.

R is a chute beneath the man-hole, into which the oil and refuse material is received. The oil drains away into any suitable receiver. L is a door or slide at the bottom of this chute, which is opened when this refuse material is to be drawn off.

The tank B is caused to revolve during the operation of rendering by any suitable apparatus for that purpose. A convenient method of accomplishing this is shown in Figs. 3 and 6.

K represents cogs or a cog-wheel, applied to one end of the cylindrical tank, which is operated by pinion M, connected with pulley N. This pulley may be driven by any suitable means.

The revolving of the tank should be at the rate of from seven to twenty per minute, varying somewhat with the size of the tank, the degree of heat, and the condition of the material to be rendered.

Among the advantages secured by the use of this apparatus, as compared with that shown in the patent of January 25, 1870, are the following: The current of heated air passes directly through the fatty matter. It is capable of feeding while in operation, and of a continuous discharge. By means of the exhaust-fan the heated air and gases are more rapidly drawn off, the pressure upon the walls of the tank is avoided, and the escape of disagreeable odors prevented.

We are aware that pipes conducting hot air through the interior of oil-retorts have been shown in Letters Patent No. 157,432, granted J. H. Van Houten, December 1, 1874, and we lay no claim to these devices.

What we claim as our invention is—

1. The combination, in a rendering-machine, of the revolving tank B, into which the material to be rendered is introduced, the hot-air pipe E, conducting a blast of heated air directly into said tank, and the feed-pipe C, conducting the material to be rendered into said tank while in operation, substantially as shown and described.

2. The combination, with the revolving tank B of a hot-air rendering-machine, of bars and chains *b b c c*, one or both, for the purpose of dividing and agitating the animal matter, and

assisting in its reduction, substantially as described.

AMOR SMITH.
LEANDER SMITH.
AMOR SMITH, JR.

Witness as to AMOR SMITH and AMOR SMITH, Jr.:

JOHN W. LAYMAN.

Witness as to LEANDER SMITH:

JEREMIAH F. TWOHIG.

Witness as to all:

WM. S. BATES.