

KATE C. BARTON
SEWING-MACHINE.

No. 182,096.

Patented Sept. 12, 1876.

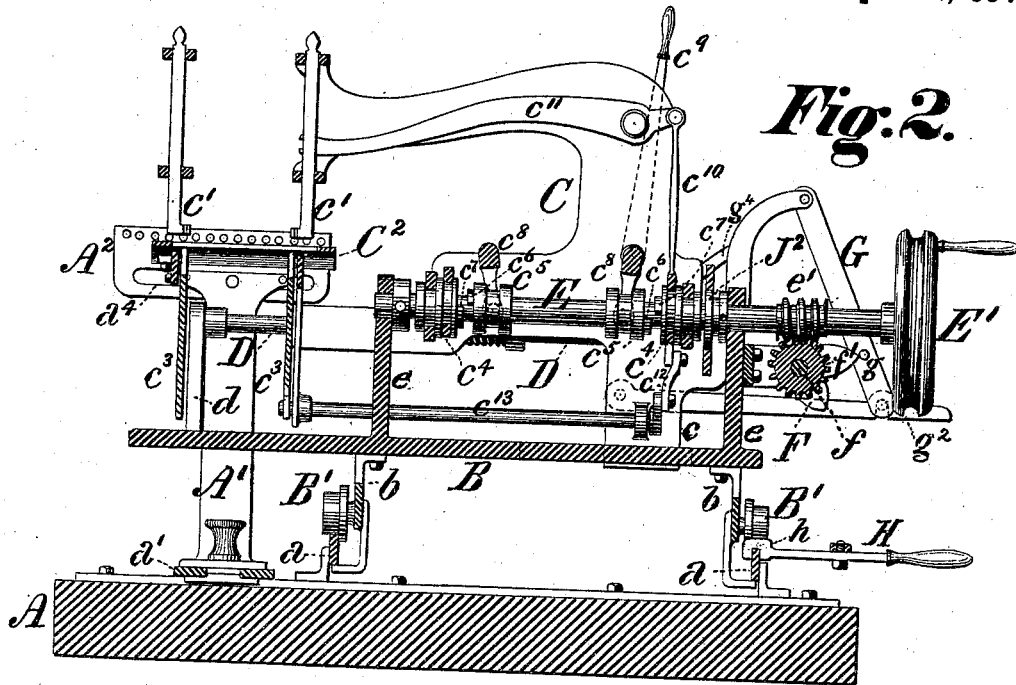

Fig. 2.

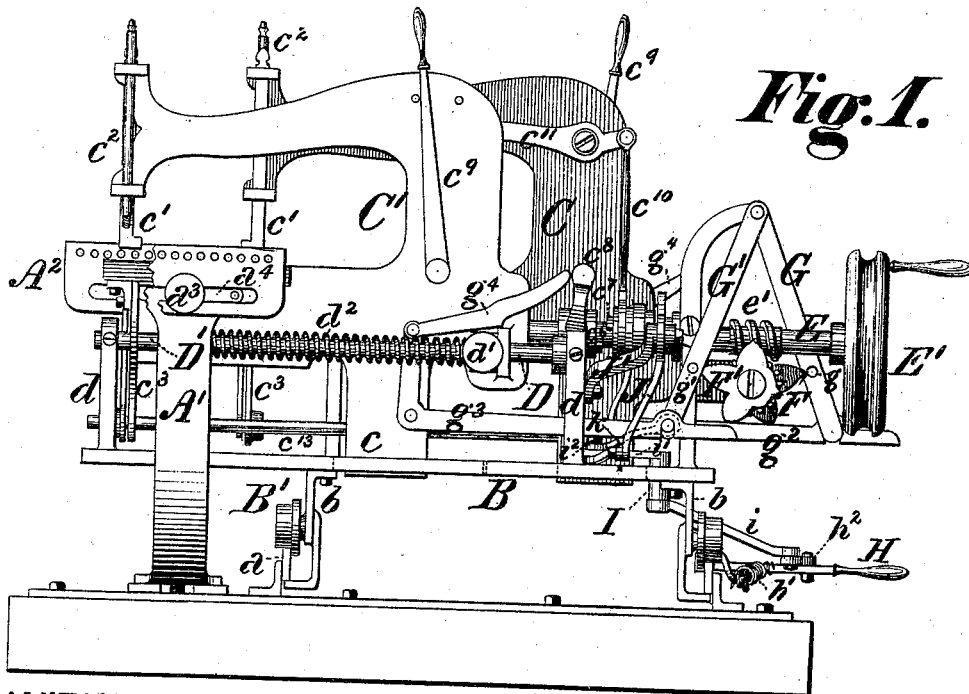

Fig. 1.

WITNESSES

Geo. A. Vaillant.
D. L. Bollier.

INVENTOR

Kate C. Barton,
by J. Thomson Bell,
att'y

KATE C. BARTON.
SEWING-MACHINE.

No. 182,096.

Patented Sept. 12, 1876.

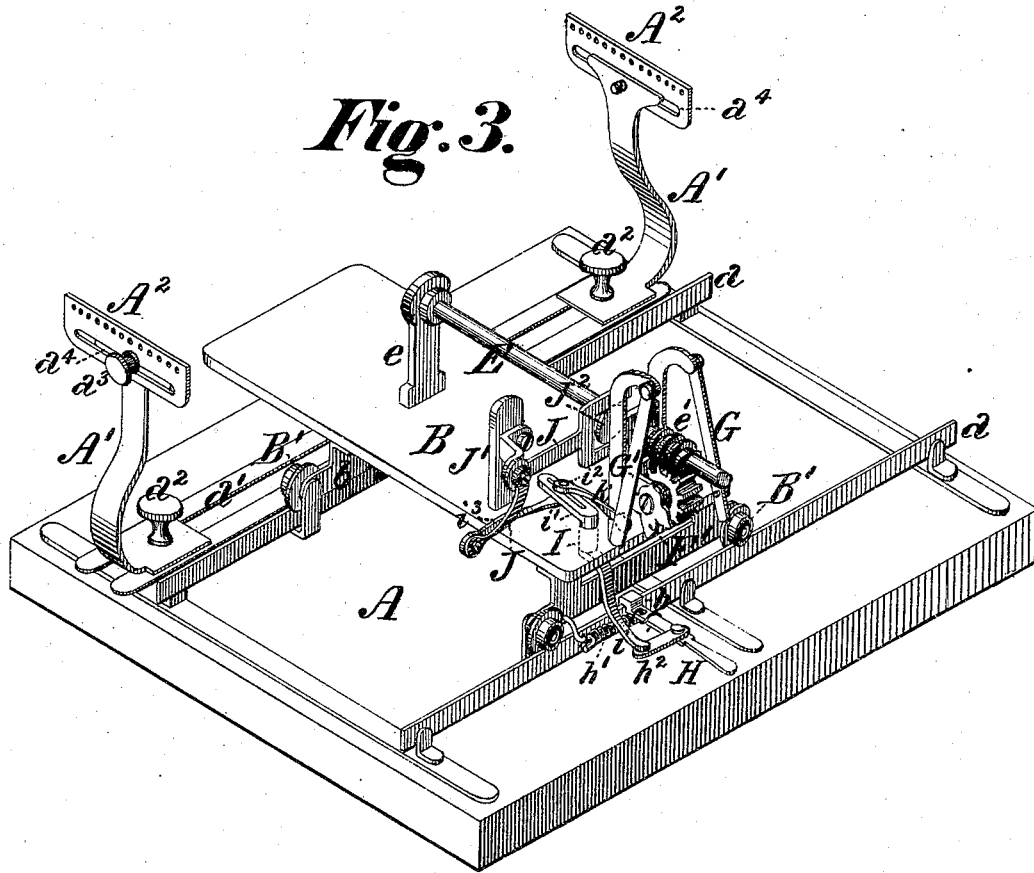
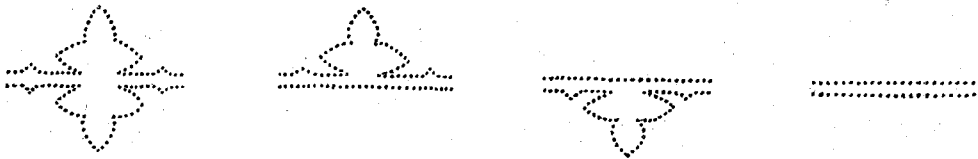

Fig. 4.



WITNESSES

Geo. A. Vaillant
D. L. Collier

INVENTOR

Kate C. Barton,
by J. Thomson Bell,
att'y.

UNITED STATES PATENT OFFICE.

KATE C. BARTON, OF PHILADELPHIA, PENNSYLVANIA.

IMPROVEMENT IN SEWING-MACHINES.

Specification forming part of Letters Patent No. 182,096, dated September 12, 1876; application filed March 25, 1876.

To all whom it may concern:

Be it known that I, KATE C. BARTON, of the city and county of Philadelphia, in the State of Pennsylvania, have invented certain new and useful Improvements in Sewing-Machines, of which the following is a specification:

The object of my invention is to provide a machine for sewing two or more seams, each and all of which may be either straight for their whole length, partly straight and partly curved or zigzag, according to a prescribed design, or composed entirely of a series of curved or zigzag figures, as may be required; to which end my improvements consist in the combination of a stationary table or bed plate, an adjustable cloth-holder, a carriage traversing on rails on the bed-plate, a series of frames, each carrying separate sewing mechanism, and having the capacity of reciprocating at right angles to the direction of the movement of the carriage, a driving-shaft and pattern-cams which operate the sewing mechanism and impart reciprocating movement to the frames carrying the same, and a feeding device, operated from the driving-shaft, and imparting longitudinal movement to the carriage, these members being combined for joint operation in manner hereinafter fully set forth.

In the accompanying drawings, Figure 1 is an end view of a sewing-machine embodying my improvements; Fig. 2, a vertical transverse central section of the same; Fig. 3, a view in perspective, with the sewing mechanisms and their supporting-frames removed; and Fig. 4, a diagram showing the form of seams made by the machine.

To carry out the object of my invention, I provide a table or bed-plate, A, having secured longitudinally upon it two track-rails, *a*, and a slotted guide-bar, *a'*, upon which two vertical posts, *A'*, may be adjusted at any desired distance apart by set-screws *a*². A cloth-holder, *A*², is connected to each of the posts *A*¹ by a set-screw, *a*³, passing through a long slot, *a*⁴, in its lower side, its upper side being suitably recessed or perforated for the reception of one end of the fabric to be sewed. By this arrangement both longitudinal and trans-

verse adjustment of the fabric may be made, and the same stretched as tightly as required.

A carriage, B, is supported on flanged wheels B', which are journaled on its feet *b*, and traverse the track-rails *a* of the table. Two or more frames, C C¹, each carrying a needle-bar, *c*¹, presser-bar *c*², shuttle-carrier *c*³, and an eccentric, *c*⁴, provided with proper connections for operating the needle-bar and shuttle-carrier, are mounted loosely on horizontal guide bars or rods D D', secured to standards *d* upon the carriage B, at right angles to the rails *a*, upon which the latter traverses. A cloth-plate, C², slotted to permit the passage of the needles through it, is secured to one of the frames, its slot being common to both needles. A downwardly-projecting arm, *c*, on each frame enters a transverse slot in the carriage, and, in connection with the guides D D', maintain the same in vertical position, and insures its rectilinear traverse when acted upon by the cam to be hereinafter described.

A horizontal driving-shaft, E, is mounted in bearings upon standards *e e* on the carriage B, and is rotated by a crank-wheel, E'. The eccentrics *c*⁴, which operate the sewing mechanisms of the frames C C¹, are each loose upon the driving-shaft, and are, respectively, caused to rotate therewith by clutches *c*⁵, one of which is provided for each frame, and has a feather which enters a longitudinal groove in the driving-shaft, so as to admit of end motion thereon while rotating therewith. Pins or catches *c*⁶ on the ends of the clutches engage corresponding stops *c*⁷ on the eccentrics, when moved into gear therewith by shippers *c*⁸ pivoted to the frames C C¹, and provided with levers *c*⁹.

It will thus be apparent that either or both of the sewing mechanisms can be made to operate or be stopped whenever required. The strap of each eccentric is connected by a rod, *c*¹⁰, to one of the needle-arms, *c*¹¹, and by a link, *c*¹², to one of the shafts, *c*¹³, which operate the respective shuttle carriers or loopers of the frames.

Reciprocating motion, at right angles to the line of the track-rails *a*, is imparted to the frames C C¹ in the following manner: A worm,

e^1 , on the driving-shaft E, meshes with a worm-wheel, f^1 , on a lower transverse shaft, f , mounted in bearings on the carriage B, and having pattern-cams F F' secured upon its ends. The outline of the cams is made to conform with the curved or zigzag design which it is desired to produce upon the seam, and the frames C C', with their sewing mechanism, are moved laterally in accordance therewith by the action of the cams on pins g^1 attached respectively to the vibrating arms G and G', the upper ends of which arms are pivoted to standards on the carriage B, and their lower ends connected by links $g^2 g^3$ to the frames C and C' respectively.

The mode of attaching the links $g^2 g^3$ to the arms G G' is by gabs or notches, which fit over pins on the links, so that one or both of the links may be disengaged from the arms at pleasure by the unhooking-levers g^4 , for the purpose of causing the corresponding frame or frames to remain stationary relatively to the carriage B.

The straight portion of the seams, if any, will be sewed during such periods as the reciprocating motion of the frames is thus interrupted. If a seam or seams straight through their entire extent are to be sewed, the frames, after being disconnected as above, may be clamped fast at any desired distance apart upon their guide-bars D D' by set-screws d^1 .

In this instance, the frames are shown as moved toward the cloth-holders by the pattern-cams, and in the opposite direction by springs d^2 coiled upon the guide-bars D D'; but if the pattern-cams be formed with grooves so as to embrace the pins of the arms G G', it is evident that they will move the frames in both directions, and, in such case, the springs may be dispensed with.

The carriage B is fed longitudinally along the rails a by a friction-clutch lever, H, having at its inner end a jaw, h , which embraces one of the rails, and is held in such position thereon as will permit motion of the carriage only in a forward direction by a coiled spring, h^1 , which connects the lever with a pin on the carriage. A link, h^2 , is pivoted at one end to the clutch-lever H, and at the other to the lower arm i of a vertical rock-shaft, I, the upper arm i^1 of which is slotted to receive a pin, i^2 , connected by a link, i^3 , to the lower arm of a bell-crank, J, pivoted to a bearing, J^1 , on the carriage, and also connected by a link, k , to a pin on the lower end of the vibrating arm G', which operates the frame C'. The bell-crank J is oscillated by a cam, J^2 , on the driving-shaft E, working in a recess or frame in the end of its upper arm. The vibrating movement of the bell-crank is transferred to the rock-shaft I, and moves the carriage B forward at each revolution of the cam J^2 , acting against the clutch-lever H as a fulcrum on the rail a , the lever being correspondingly

drawn forward at each revolution by the spring h^1 .

The purpose of the link k is to vary the throw of the arm i^1 proportionately with the degree of transverse motion of the frames C C' on the carriage, and it should be so arranged as to be thrown out of gear with the arm G' when sewing a straight seam.

I claim as my invention and desire to secure by Letters Patent—

1. The combination of a traveling carriage, two or more frames carrying sewing mechanism, and moving transversely on said carriage and mechanism, substantially as set forth, for imparting independent transverse movement upon the carriage to either or both of said frames, as and for the purpose described.

2. The combination of a traveling carriage, a frame carrying sewing mechanism and moving transversely on said carriage and mechanism, substantially as described, whereby the longitudinal movement of the carriage and the transverse movement of the frame are effected by the same pattern-cam.

3. The combination of a traveling carriage and one or more frames mounted and moving transversely thereon, each carrying a sewing mechanism in which the shuttle-carrier vibrates transversely to the line of movement of its carrying-frame, substantially as set forth.

4. The combination of two frames, each carrying sewing mechanism, and moving parallel to a driving-shaft, with said driving-shaft provided with mechanism, substantially as described, whereby the sewing mechanisms of the two frames are operated without regard to the relative positions of the frames and shaft, substantially as set forth.

5. The combination of a traveling carriage, two frames carrying sewing mechanisms and moving upon the carriage transversely to its line of movement, and a cloth-plate attached to one of the frames, and having a slot common to the needles of both frames, substantially as set forth.

6. The combination of a driving-shaft, two frames mounted and moving longitudinally thereon, and each carrying a sewing mechanism, and clutches and clutch-levers on said driving-shaft, whereby said sewing mechanisms may be operated therefrom either singly or together, substantially as set forth.

7. The combination of the frames C C', needle-bars $c^1 c^1$, shuttle-carriers $c^3 c^3$, driving-shaft E, and shuttle-carrier shafts $c^{13} c^{13}$, operated by said driving-shaft, substantially as set forth.

8. The combination of a pattern-cam, F, driving-shaft E, frame C, carrying sewing mechanism, and mechanism, as described, whereby said frame is connected to and moved by the pattern-cam.

9. The combination of a driving-shaft, E, worm e^1 , worm-wheel f^1 , pattern-cam F, and

traveling carriage B, provided with a feed mechanism variably operated from the pattern-cam by mechanism, substantially as set forth.

10. The combination of the carriage B, frames C C', and guide-bars D D', substantially as set forth.

11. The combination of the carriage B, movable frames C C', driving-shaft E, pattern-cams F F', vibrating arms G G', and connecting-links $g^2 g^3$, substantially as set forth.

12. The combination of the rail a , carriage B, clutch-lever H, spring h^1 , link h^2 , rock-shaft I, arms i^1 , links $i^3 k$, bell-crank J, cam J^2 , and vibrating arm G', substantially as set forth.

KATE C. BARTON.

Witnesses:

J. SNOWDEN BELL,
F. E. HARDING.