

B. N. PHELPS.  
CAR-COUPLING.

No. 182,131.

Patented Sept. 12, 1876.

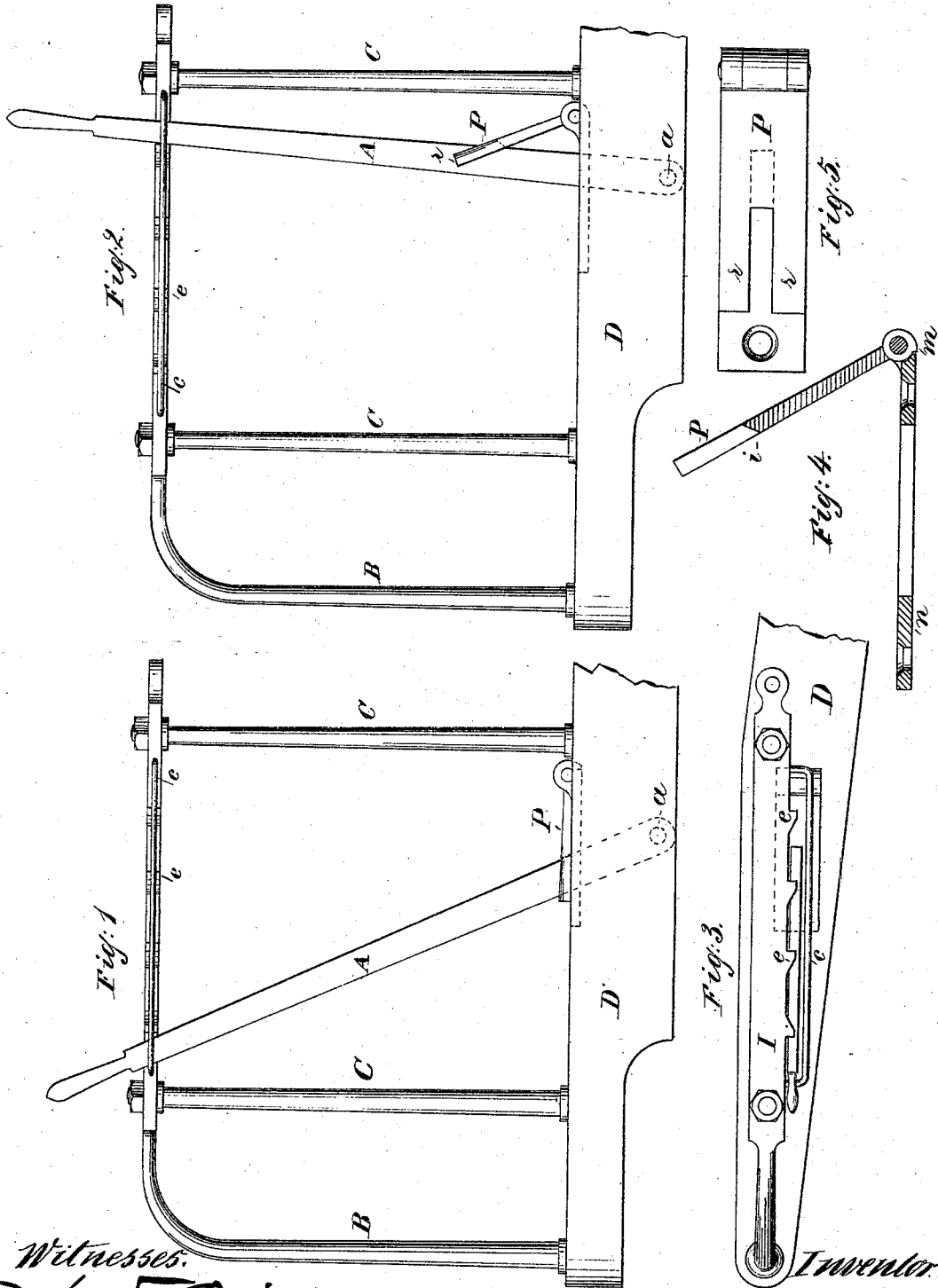

Witnesses:  
John F. Collins  
John L. Kluber,

Inventor:  
Bradley N. Phelps,  
by Hanson & Phillips,  
attorneys.

# UNITED STATES PATENT OFFICE.

BRADLEY N. PHELPS, OF TREMONT, N. Y.

## IMPROVEMENT IN CAR-COUPINGS.

Specification forming part of Letters Patent No. **182,131**, dated September 12, 1876; application filed August 21, 1876.

*To all whom it may concern:*

Be it known that I, BRADLEY N. PHELPS, of Tremont, New York county, State of New York, have invented a new and useful Improvement in Car-Couplings, of which the following is a full, clear, and exact description, reference being had to the accompanying drawings, in which—

Figure 1 is a side elevation of a portion of a car-platform with my invention applied to it; Fig. 2, a similar view, with the parts in a different position; Fig. 3, a top view of Fig. 1; Fig. 4, a longitudinal section of the plates constituting the cover and its frame; Fig. 5, a top view of the same.

The invention relates to that class of car-couplings in which horizontally-pivoted and spring-seated coupling-hooks are adapted to interlock when the two members of a pair are forced together, which said coupling-hooks are linked to actuating-levers which extend vertically through the car-platform, and operate to draw backward or disengage the said hooks.

The invention consists in the combination, with the actuating-lever of such a car-coupling hook, of an automatically-operating cover for protecting the slot in the head-beam of the car in which such lever operates, and in details of construction, all of which will be more particularly hereinafter pointed out.

In the modern construction of railroad-cars they are provided with coupling devices which are simple hooks formed in the ends of the horizontal draft-bar, and the said draft-bar is pivoted at one end and spring-seated, so that it may move laterally to a degree sufficient to allow the hooked ends of the draft-bars of two cars to pass by each other and interlock, whereby the said two cars become coupled together. One efficient mode of disengaging such couplings is by means of a chain attached to the draft-bar and to the lower end of a lever extending vertically through the platform of the car. Such a lever is shown in the drawing, and marked A. It is fulcrumed at *a*, and plays back and forth in a slot cut through the head-beam D, while its free end is prevented from lateral displacement by a guard-bar, *c*, attached to the hand or guard rail B, which is fastened to the platform, as is

usual, by posts C fixed in and rising from the head-beam D. This lever A is locked in any position of its range of movement by detents or ratchet-teeth *e* cut in the top bar I of the hand or guard rail B, as is common.

As thus far described, the parts are constructed, as is the present practice, with the most approved forms of automatic car-couplings.

In practical operation, the slot through the head-beam D, in which this lever A plays, is frequently choked up either by dirt accumulated upon the platform, or by means of snow or ice which in winter becomes deposited therein. Such obstructions prevent the proper working of the lever, and consequently detract from the usefulness of the device. This objection has been to a certain degree overcome by means of a plug or capped plate chained to the platform, and adapted to be inserted in the slot when the lever A is in the position shown in Fig. 1, forming both a cover protecting the slot from filling up and a lock to hold the lever in place. But it has been found by experience that in making a running switch it is often impossible to quickly remove this plug or capped plate, while in winter it often becomes immovably fixed in place by snow and ice. To remove all of these objections I provide a plate, P, hinged to the platform in such a position that it may perfectly cover the slot in which the lever A plays when the said lever is thrown back, as in Fig. 1, which is the position occupied by it when the cars are coupled, the edge of the plate P bearing against the face of said lever being beveled to fit the same, as shown at *i*, Fig. 4, in which position it perfectly covers and protects the slot from extraneous matter. When the lever is carried toward the position shown in Fig. 2, as is the case in uncoupling cars, this movement will automatically raise the plate P, as shown, exposing the slot, and permitting the unobstructed motion of the lever A. In the reverse movement of the lever A this plate P falls into place by gravity, and lies over the slot, as shown in Figs. 1 and 3. This plate P is illustrated as bifurcated at its forward end, so as to form two arms, *r*, which embrace the lever A. While this is a desirable form, it is by no means an essential one. The

said plate is also shown in Fig. 4 as hinged to a frame, *n*, which is provided with screw-holes for attaching it to the head-beam D.

This construction affords an economical mode of manufacture, and provides a means for quickly and accurately adjusting the plate P in place. It also admits of the provision of an efficient stop, which prevents the plate P from being thrown backward, and past its center of gravity, whereby it would be prevented from following the backward movement of lever P. This stop is a simple shoulder, *m*, cast upon the tubular part of the hinge, and arranged to abut against the end of the frame *n*, and limit the backward movement of the plate P. Any other form of stop may be provided, such as an arm projecting from the plate, and engaging either with the post C or the car-platform. It is not requisite that the edge of the plate P bearing upon the lever A should be beveled, as the inclination of this said lever is such that it will raise the said plate, whether thus formed or not; but the form described is efficient, and therefore desirable.

What is claimed is—

1. In combination with the actuating-lever of a car-coupling of a hinged protecting cap or plate, as at P, covering the slot in which the said lever plays, substantially as described.

2. A cap or plate, as P, for covering and protecting the slot in which plays the lever actuating a car-coupling automatically raised and lowered by the movements of said lever, substantially as described.

3. The combination of the lever A, hinged cap or plate P, and a limiting-stop, as *m*, substantially as described.

4. In combination with a coupling actuating-lever, A, a hinged protecting cover or plate, P, and guiding-arms *r r*, substantially as described.

In testimony whereof I have signed my name to this specification in the presence of two subscribing witnesses.

BRADLEY N. PHELPS.

Witnesses:

H. P. MUNSON,  
M. B. PHILIPP.