

T. R. ALMOND.

BURNERS FOR HEATING PURPOSES.

No. 182,145.

Patented Sept. 12, 1876.

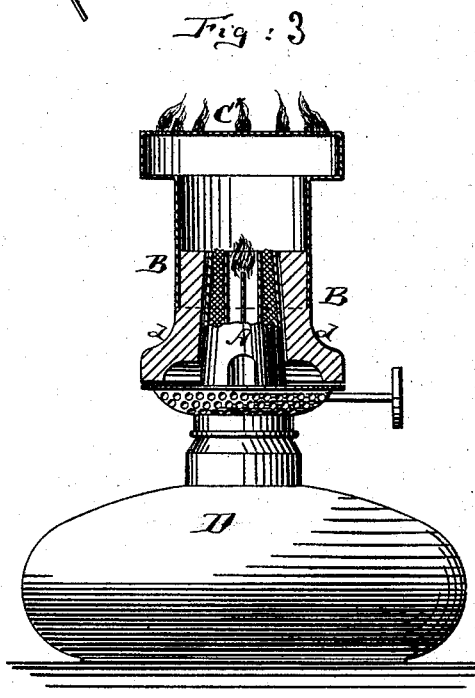
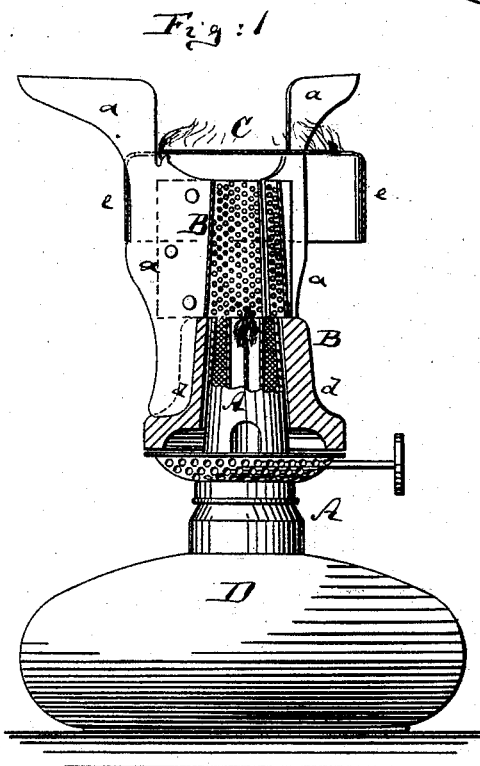
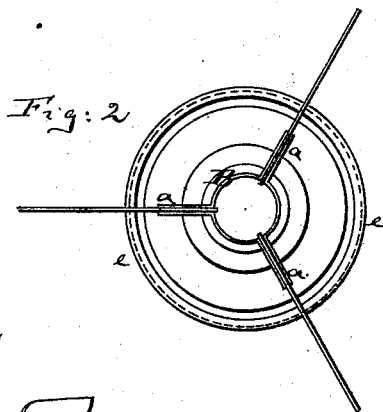
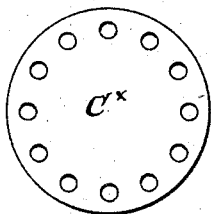

Fig: 4



Witnesses:

A. Moraga  
H. A. Gunther.

Inventor:

Thomas R. Almond  
by his attorney  
Chas. Briesen

# UNITED STATES PATENT OFFICE.

THOMAS R. ALMOND, OF BROOKLYN, NEW YORK, ASSIGNOR OF ONE-HALF HIS RIGHT TO EMELYN L. FOBES, OF MALDEN, MASSACHUSETTS, AND SAID T. R. ALMOND AND E. L. FOBES ASSIGNORS OF ONE-THIRD OF THEIR RIGHT TO AMASA S. FOBES, OF CAMBRIDGE, MASS.

## IMPROVEMENT IN BURNERS FOR HEATING PURPOSES.

Specification forming part of Letters Patent No. 182,145, dated September 12, 1876; application filed August 4, 1876.

*To all whom it may concern:*

Be it known that I, THOMAS R. ALMOND, of Brooklyn, in the county of Kings and State of New York, have invented a new and Improved Burner for Heating Purposes, of which the following is a specification:

Figure 1 is a sectional elevation of my improved burner for heating purposes. Fig. 2 is a top view of the same. Fig. 3 is a sectional elevation of a modification of the same, and Fig. 4 a top view thereof.

Similar letters of reference indicate corresponding parts in all the figures.

This invention relates to a new attachment to the ordinary burners of kerosene or other coal-oil lamps, and has for its object to utilize the flame of such a lamp to vaporize, but not consume, part of the fuel that is conducted to such flame, so that the vapors may be used in a separate flame for heating purposes.

I have found that by placing a draft-impeding chamber over an ordinary lamp-burner the result above referred to will be attained, and that I can in consequence obtain from an ordinary lamp a flame of far superior heating capacity to any flame that can be obtained by direct consumption of the liquid fuel.

My invention consists in the combination of the vapor-generating chamber with a lamp-burner; also, in several features of importance in the construction of the vapor-generating chamber.

In the drawing, the letter A represents a lamp-burner, of annular or other form, placed upon a coal-oil lamp, D, and supplied with fuel by capillary attraction, in the ordinary or suitable manner. B is my improved attachment, the same being a short chimney, of such diameter that its lower part will embrace the outer tube of the burner. When placed on the burner, as in Figs. 1 and 3, the chimney or attachment B will project a short distance above the burner, not sufficient, however, to produce a perfect draft for the flame on the burner. Over the top of the chimney is placed a flat, concave, or other shaped plate, C, as in Fig. 1, the same resting on brackets or arms *a*, that project beyond the chimney, as shown;

or the top of the chimney may, as in Figs. 3 and 4, be formed of a perforated plate, C<sup>x</sup>, of fire-proof material, such as asbestos-paper. The lower part *d* of the chimney B should be made of wood or other bad heat-conductor, to protect the burner A against excessive heat. Above this non-conducting base the chimney is, by preference, perforated, as in Fig. 1, to admit oxygen to the vapor, and a perforated diaphragm may be placed in the chimney, to prevent the vapor-flame from striking back toward the burner A, and for other evident purposes. An annulus, *e*, may be secured to the brackets *a* around the upper part of the chimney, to protect the vapor-flame from draft. When the flame on the burner is lighted, and the attachment B placed upon the burner, the flame on A will at once cease to burn on the wick, but will dwindle into very small proportions, and burn only in the central air-passage of the burner, as indicated in Figs. 1 and 3. This novel effect is obtained, I believe, by stifling the draft of the burner with the attachment B. The small flame on the burner will, however, vaporize the fuel fed to the top of the burner by capillary attraction, and these vapors will ascend to the top of the chimney, where they can be ignited, as in Figs. 1 and 3, to produce a heating-flame of great power and considerable extent.

The plate C, if made quite thin, will soon become red hot, and thereby prevent all accumulation of soot. If made concave, it will produce a better heating-flame than if made flat, owing, I believe, to the flaring form of opening then produced. The body of the chimney B may be perforated to admit a supply of air to the vapors that ascend in the chimney; but these perforations are not absolutely necessary, as some air will reach the vapors through the central shaft of the burner, and some at the top of the attachment B, where the vapors are ignited.

It will be seen that by my attachment I cause the flame of the burner A to create vapors out of the same body of fuel that feeds said flame, said vapors serving afterward to feed another flame for heating purposes. The vapor-flame

above the plate C, in which case they will serve to support the heating-vessel. The brackets *a* may, if desired, be extended I claim as my invention—

1. The attachment B, constructed for application to a lamp-burner, and closed partly on top for the purpose of causing the flame of the burner to vaporize part of the fuel, and allowing said vapors to feed a second flame in the upper part of the attachment, substantially as specified.

2. The plate C, applied to and combined with the vaporizing and vapor-burner attachment B, substantially as specified.

3. The vaporizing-chimney and vapor-burner B, combined with the exterior annulus *e*, substantially as specified.

4. The vaporizing-chimney and vapor-burner B, made perforated above the base *d*, substantially as specified.

5. The vaporizing-chimney and vapor-burner B, combined with the arms or brackets *a*, substantially as specified.

The foregoing description of my invention signed by me this 28th day of July, 1876.

THOMAS R. ALMOND.

Witnesses:

L. L. FOBES,

ERNEST C. WEBB.