

J. BERRY & J. GILES.
GRINDING-MACHINE.

No. 182,151.

Patented Sept. 12, 1876.

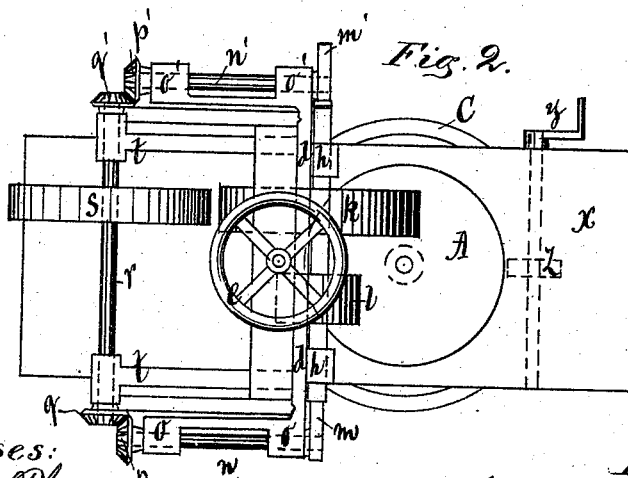
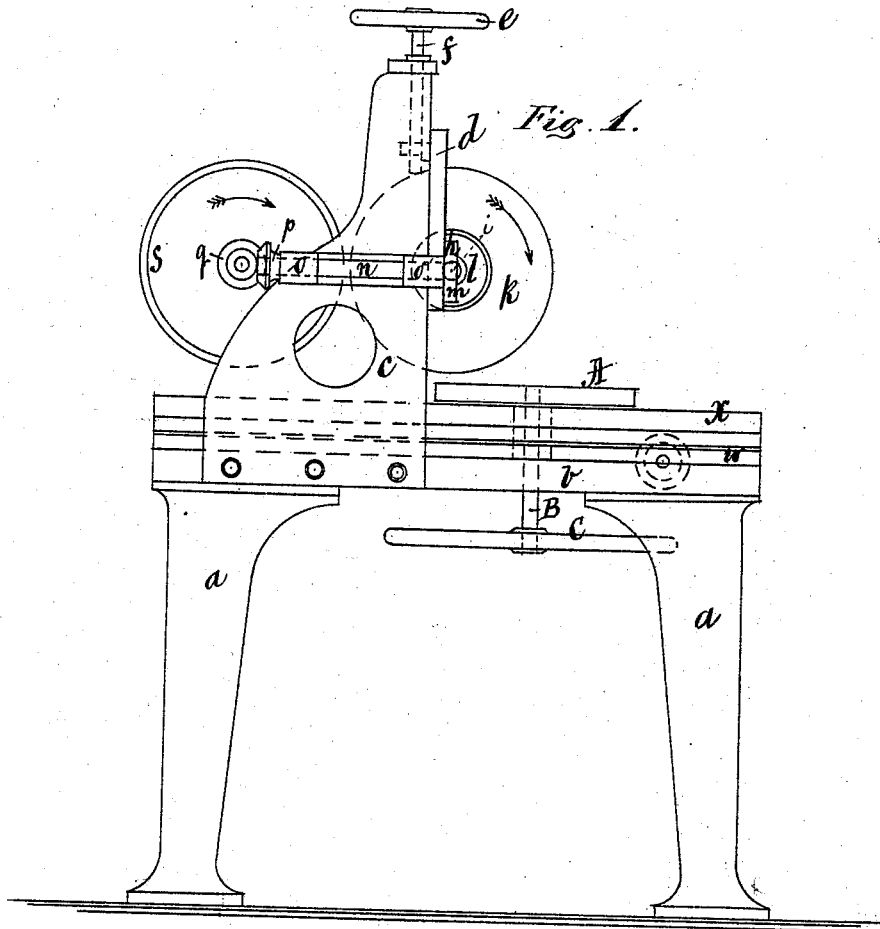

Witnesses:
 George C. Phelps.
 John C. Heard

Inventors:
 Joe Berry and Jason Giles
 by Wm. Andrews atty.

J. BERRY & J. GILES.
GRINDING-MACHINE.

No. 182,151.

Patented Sept. 12, 1876.

Fig. 3.

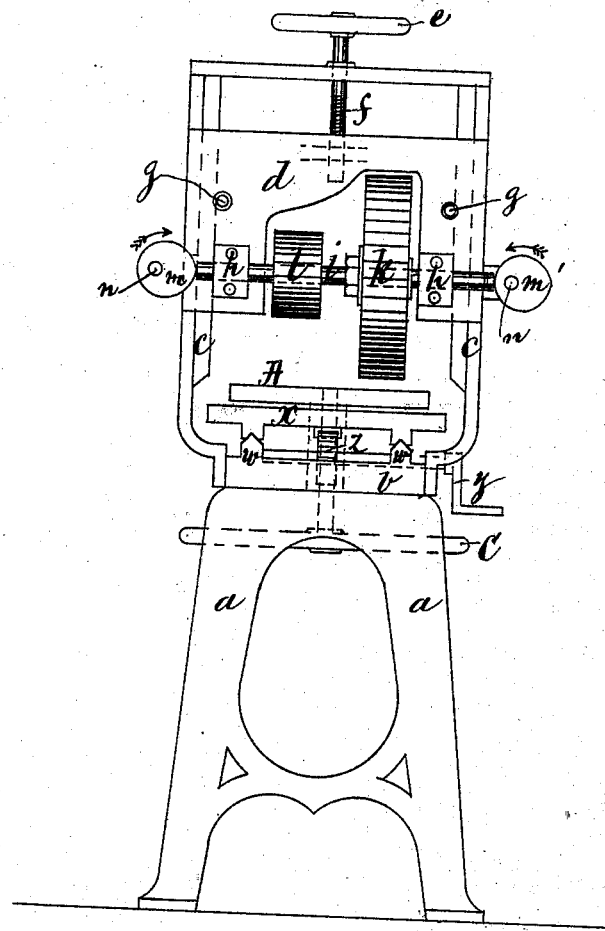
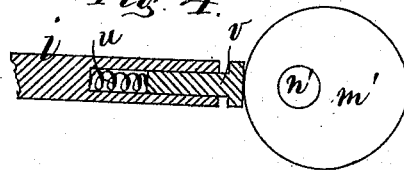

Fig. 4.



Witnesses:
 George E. Phelps.
 John H. Beard.

Inventors:
 Joe Berry and Jason Giles.
 by Alban Andrew atty.

UNITED STATES PATENT OFFICE.

JOE BERRY, OF MANCHESTER, GREAT BRITAIN, AND JASON GILES, OF HYDE PARK, MASSACHUSETTS.

IMPROVEMENT IN GRINDING-MACHINES.

Specification forming part of Letters Patent No. 182,151, dated September 12, 1876; application filed December 27, 1873.

To all whom it may concern:

Be it known that we, JOE BERRY, of Manchester, in the county of Lancashire and Kingdom of Great Britain, and JASON GILES, of Hyde Park, in the county of Norfolk and State of Massachusetts, have jointly invented certain new and useful Improvements in Grinding-Machines; and we do hereby declare the following to be a full, clear, and exact description of the invention, such as will enable others skilled in the art to which it pertains to make and use it, reference being had to the accompanying drawings, which form part of this specification.

Our invention relates to improvements in grinding-machines for the purpose of dressing and grinding plane surfaces; and consists in the employment of a rotary grinding-wheel, secured to a shaft, to which is given a lateral motion by means of cams in one or both ends of said shaft, by which arrangement the grinder will always wear itself to a true circle as well as evenly across its face. The article to be ground is secured to a vertically-adjustable plate or rest that is also moved horizontally by means of a crank-wheel and rack.

On the drawing, Figure 1 represents a side elevation of our invention. Fig. 2 represents a ground plan. Fig. 3 represents an end view, and Fig. 4 represents a longitudinal section, of one end of the grinder-shaft.

Similar letters refer to similar parts wherever they occur on the different parts of the drawings.

a represents the supports for the bed-plate *b*. To the stationary plate *b* is secured the standards *c c*, provided with guides, on which the frame *d* is made to move up and down. The frame *d* may be operated by means of the hand-wheel *e* and screw *f*, in the ordinary way. When the frame *d* is placed in any desired position, it may, furthermore, be secured to the standards *c c* by means of holding-bolts *g g*, or similar arrangement. To the frame *d* are secured two bearings, *h h*, for the grinder-shaft *i* to revolve in. To the shaft *i* is secured a circular grinding-wheel, *k*, that is set in rotary motion by means of power applied to the belt-pulley *l*, or in any other suitable manner. Besides the rotary motion of the grinding-

wheel *k*, we also give to it a lateral motion by means of the rotary eccentric cams *m m'* secured to the shafts *n n'*. The shafts *n n'* are movable in bearings *o o' o'*, that are secured to the frame *d*. To each of the cam-shafts *n n'* is secured a bevel-gear, *p p'*, that engage with similar gears *q q'* secured to the cross-shaft *r*. The shaft *r* is set in rotary motion by means of power applied to a belt-pulley, *S*, or in any similar way. The shaft *r* is movable in bearings *t t*, that are secured to the frame *d*, so that the shafts *n n' r*, with their gears, cams, and pulley, follow the motion of the frame *d* as it is raised and lowered. We do not, however, confine ourselves to this peculiar arrangement for operating the cams *m m'*, nor to the exact shape and form of the cams *m m'*, as shown in the drawings, as we may substitute any similar arrangement and any kind of cams, whether grooved or plain, as may be desirable.

To prevent undue play between the ends of the shaft *i* and the cams *m m'*, we construct one or both ends of the shaft *i* in a manner as shown in Fig. 4. For this reason we perforate the end of the shaft as shown in said figure, and place in the said hollow shaft a spiral or other spring, *u*, that presses against an intermediate piece, *v*, interposed between the cam *m'* and the said spring *u*. The cylindrical piece *v* is guided in the tubular recess in the end of the shaft *i*, as shown in Fig. 4.

The bed-plate *b* is provided with suitable parallel guides or ways *w w*, on which the carriage *x* is made to move in a manner common on planing-machines, and may be operated by means of a crank, *y*, pinion *z*, and a toothed rack on the under side of the carriage *x*, or by means of other well-known devices.

A plate or rest, *A*, to which the article that is to be ground is to be secured, is made adjustable up and down in a sleeve or bearing in the carriage *x*, and is for this purpose operated by means of a screw-shaft, *B*, and its hand-wheel *C*, or in a similar way.

Our improved grinding-machine is operated in the following manner: The piece that is to be ground is secured in a suitable way to the adjustable plate *A*, and the grinder *k* is set in a rotary motion around its axis, as well as in

a lateral motion, by means of the shafts *n n'*, their connections to the pulley *S*, and the cams *m m'*, as hereinabove set forth. The carriage *x*, with the plate *A*, is moved forward and back under the revolving and laterally moving grinder *k* till the whole surface of the piece operated upon has been reached by the grinder. If still more is to be ground off the said piece the plate *A* is raised up the required distance by means of the hand-wheel *C* and screw-shaft *B*. As the grinder *k* wears off, the frame *d* can be moved downward a corresponding distance by means of the hand-wheel *e* and screw *f*. The advantages obtained with our machine are, that we are able to grind and produce a true and even surface of the piece we operate upon, and the grinder *k* will wear itself to a true circle, no matter how oval when first secured to the grinder-shaft *i*.

We do not confine ourselves to any particular kind of a grinder, as the same may be made of emery, or any other well-known material, as may be required for different kinds of work.

Having thus fully described the nature, con-

struction, and operation of our invention, we wish to secure by Letters Patent, and claim—

1. In combination with the rotary and laterally moved grinder *k*, the vertically-adjustable plate or rest *A*, screw-spindle *B*, and wheel *C*, and the horizontally-adjustable carriage *x*, all arranged and constructed in a manner and for the purpose as herein shown and described.

2. In combination with the grinder *k* and its shaft *i*, the shafts *n n' r*, pinions *p p' q q'*, and the cams *m m'*, as and for the purpose set forth.

3. In combination with the shaft *i* and cams *m m'*, one or both ends of said shaft *i* bored out for the reception of the spring *u* and cylinder *v*, for the purpose as herein fully set forth and described.

In testimony that we claim the foregoing we have hereunto set our hands this 10th day of November, 1873.

JOE BERRY.
JASON GILES.

Witnesses:
ALBAN ANDRÉN,
W. F. BROWN.