

J. L. BOONE.

CARRIER ATTACHMENT FOR SEWING-MACHINES.

No. 182,158.

Patented Sept. 12, 1876.

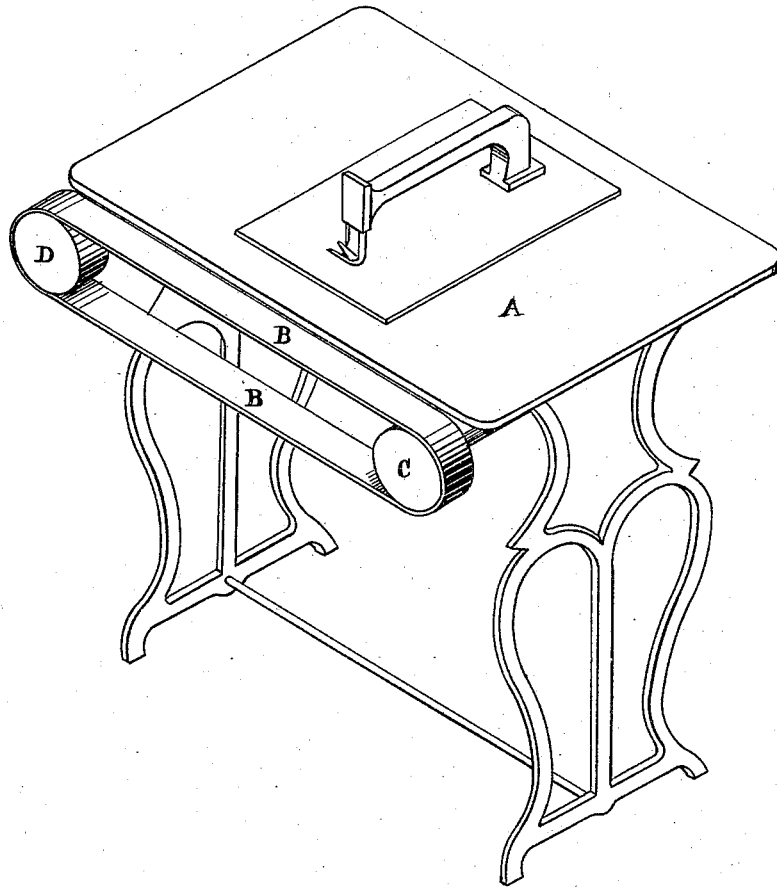

Witnesses  
*Geo. H. Strong.*  
*Cloyce T. Stacy-*

Inventor  
*John L. Boone*  
*by Neway & Co*  
*Attys.*

# UNITED STATES PATENT OFFICE.

JOHN L. BOONE, OF SAN FRANCISCO, CALIFORNIA.

## IMPROVEMENT IN CARRIER ATTACHMENTS FOR SEWING-MACHINES.

Specification forming part of Letters Patent No. **182,158**, dated September 12, 1876; application filed June 2, 1876.

*To all whom it may concern :*

Be it known that I, JOHN L. BOONE, of the city and county of San Francisco, and State of California, have invented a Carrier Attachment for Sewing-Machines; and I do hereby declare the following description and accompanying drawings are sufficient to enable any person skilled in the art or science to which it most nearly appertains to make and use my said invention without further invention or experiment.

My invention relates to a carrier to be connected with a sewing-machine provided with one of the ordinary feeds beneath the presser-foot, the object of which is to carry sewed material in front of the machine while it is sewing another seam, and the feed beneath the presser-foot feeds to the needle. This feeder or carrier is especially useful in connection with a sewing-machine which is used for sewing carpets, canvas, and other heavy and unwieldy material, where several breadths are to be sewed together, and the office of the feeder or carrier is to carry the sewed breadths in front of the machine while the machine is sewing another breadth to the edge of the already sewed carpet or other heavy material.

Referring to the accompanying drawings, let A represent the table of any sewing-machine which is capable of sewing heavy material, such as carpets, canvas, ducking, and the like. In front of this machine I construct a carrier, B, upon which the sewed material is supported and carried along in front of the machine while the machine is sewing on another breadth. This carrier consists of an endless belt, B, mounted on pulleys C in front of the sewing-machine.

The shafts of pulleys C may be connected by gearing with the driving mechanism of the machine.

By the use of this carrier, I am able to handle heavy carpets and other materials with ease.

The carrier will convey the sewed material along in front of the machine as it sews on the widths, and when a width has been sewed on, if desired, mechanism can be added so that the motion of the carrier can be reversed, and the entire material moved back, independent of the machine, by hand or otherwise, into position ready to sew on another width.

I am aware that heretofore an endless belt has been used to feed the material under the presser-foot to the needle; but this I do not claim, as my device is intended to act as a support to the material while one of the well-known feeding devices feeds the material to the needle.

Having described my invention, I claim—

In combination with a sewing-machine provided with a feeding device beneath the presser-foot, a carrier consisting of the endless belt B and one or more drums arranged in front of a sewing-machine, so as to carry the heavy sewed material in either direction, substantially as and for the purpose above specified.

In witness whereof I have hereunto set my hand and seal.

JOHN L. BOONE. [L. s.]

Witnesses:

GEO. H. STRONG,  
CHAS. G. PAGE.