

L. F. GRANT.

MACHINES FOR CUTTING COGS IN CLOCK-WHEELS.

No. 182,186.

Patented Sept. 12, 1876.

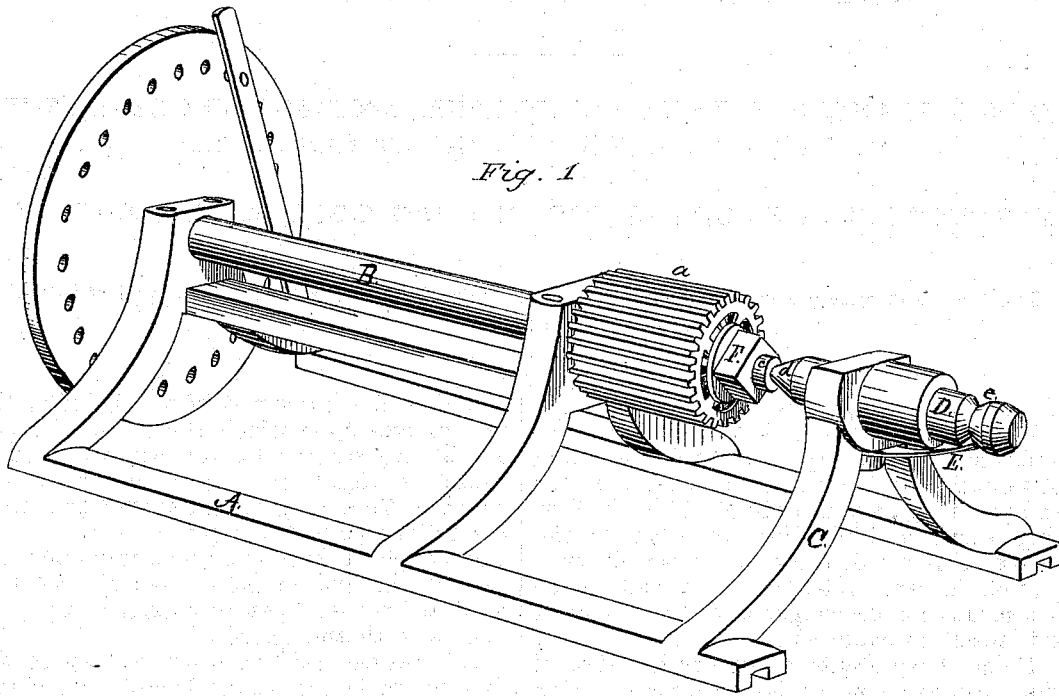

Fig. 1.

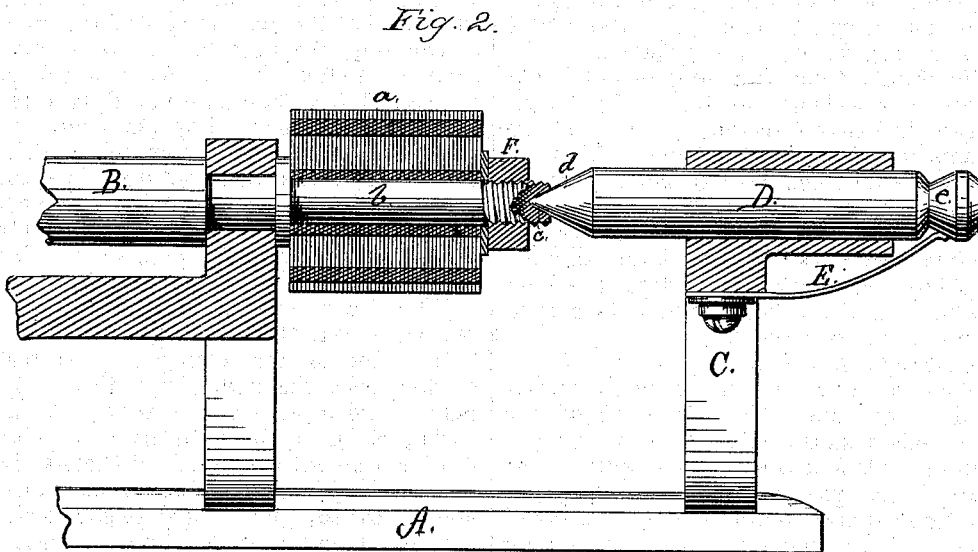

Fig. 2.

Witnesses:

C. Clarence Poole
C. Lee

Inventor

Louis F. Grant
Ass^o to Wm L. Gilbert.
By G. B. Woodruff Attorney.

UNITED STATES PATENT OFFICE.

LOUIS F. GRANT, OF WINSTED, CONNECTICUT, ASSIGNOR OF ONE-HALF HIS
RIGHT TO WILLIAM L. GILBERT, OF SAME PLACE.

IMPROVEMENT IN MACHINES FOR CUTTING COGS IN CLOCK-WHEELS.

Specification forming part of Letters Patent No. **182,186**, dated September 12, 1876; application filed
April 28, 1876.

To all whom it may concern:

Be it known that I, LOUIS F. GRANT, of Winsted, in the county of Litchfield and State of Connecticut, have invented a certain new and useful Improvement in Machines for Cutting Cogs or Teeth in Clock-Wheels; and the following is a full, clear, and exact description of the same, reference being had to the accompanying drawings, making a part of this specification, in which—

Figure 1 represents a perspective view of the carriage, showing the dividing or index plate, the mandrel on which the row of clock-wheels are secured to be cut, and the center slide and point for supporting the end of the mandrel firmly from vibrating in cutting a long row of wheels at one time. Fig. 2 is an enlarged broken-off section of the carriage and mandrel, showing a sectional side view of the slide and center, and the spring for holding the center-point in place to the support of the projecting end of the mandrel.

My invention consists in the sliding spindle, with pointed center for supporting the long projecting portion of the mandrel, as hereinafter more fully described.

The carriage A is supported upon a frame on which a series of cutting-burs are arranged to cut and finish the teeth of the clock-wheels *a*, as they are placed in quantities on the axle *b* or projecting spindle of the mandrel B, and passed under the cutters. To the sliding carriage A there is an additional standard, C, in which is fitted the sliding spindle D in a direct line with the mandrel B, which is provided with a sunken cone-shaped center, *c*, into which the corresponding point *d* on the spindle D is fitted, so that when the sliding spindle is in position, and held by the action of the spring E in the sunken re-

cess *e* at the outer end of the spindle, the arm or axle *b*, on which the series of clock-wheels are secured by the screw-nut F, is held from vibrating or springing under the action of the revolving cutters, so that from two to four times as many wheels can be cut and finished at each operation, or at one time, as could be cut on the carriages heretofore used, and the whole series be at the same time more smooth and perfect.

It is not deemed necessary to describe the dividing-plate, or other portions of the machine, as they are very similar to the ordinary gear-cutters; but the advantages of the long axle *b*, enabling the operator to secure and cut from two to four times as many wheels at one time as by that heretofore used, results in a saving of more than fifty per cent. in time and labor in making clock-wheels, which is no small item in the manufacture. The cogs or teeth are also much more perfect in the wheels, by reason of the additional support given by the sliding spindle D, which presents no obstacle to the putting on or taking off of the wheels.

What I claim as my invention, and desire to secure by Letters Patent, is—

In a machine for cutting cogs or teeth in clock-wheels, the sliding spindle D, with its point *d* and recess *e* at the rear end, and the spring E for holding the same in place, in combination with the axle *b* of the mandrel B, substantially in the manner herein shown and described, for the purpose specified.

In testimony whereof I hereunto subscribe my name.

LOUIS F. GRANT.

Witnesses:

HENRY GAY,
EDMUND B. HULBERT.